Final Report

AE Senior Thesis
Lighting Electrical

Xiaoyin Wu
Thesis Advisors: Shawn Good,
Leslie Beahm, Dr. Kevin Houser
Apr 9th 2014

acknowledgments

I would like to thank all the individuals who have offered much help and have been very supportive of me throughout the years in AE at Penn State.

Special thanks to:

Dr. Kevin Houser	Student advisor, AE lighting professor, Penn State
Dr. Richard Mistrick	AE lighting professor, Penn State
Mr. Shawn Good	Thesis lighting advisor
Ms. Leslie Beahm	Thesis Electrical advisor
Professor Kevin Parfitt	Thesis advisor
Professor Charles Cox	Architecture advisor
Ms. Dorene Mannicia	Philips
Ms. Carol Jones	Philips
Ms. Meg Smith	Philips
Dr. Kurt Roth	Fraunhofer
Mr. J Cruz	DiMella Shaffer

And the most special thanks to my parents and all my friends that I love so much!

executive summary

The thesis is to find solution of lighting design for four spaces in the building of Fraunhofer Center of Sustainable Energy as well as the electrical system redesign to keep up with the changed lighting load. The Fraunhofer CSE building is located in Fort Point Channel in Boston. It's a historical building within in a historic neighborhood where more and more commercial and professional companies are merging in and using the old buildings as their new homes.

The thesis report discusses the existing condition of each space and the approach of the design solution, then the calculation and rendering for the solution to test the design and compare with the requirement and criteria. The existing designs were studied in the previous technical reports from last semester. And the report only includes the results of the lighting design, electrical system redesign as well as architectural and structural breadths.

In the lighting design portion, the lighting depth successfully achieved the design goals both in the qualitatively and aesthetically. Most of the criteria and requirements are met for each space and the final renderings also address the concept of the design that is proposed in the schematic design phase. For the electrical depth, new branch circuits are redesigned as well as the feeders are resized as needed.

The two breadths are focusing on the changing of interior architecture and the structure system resizing. The architectural breadth is proposed not only to change the looking of the space in the building to create a better working environment, but also to accommodate the new lighting design and provide it a more opportunities for more creative design. And the structure is automatically needed to be studied for the big change of the architecture.

April 9th, 2014

table of contents

building statistic	5
lighting design depth	8
INTRODUCTION	9
DESIGN CONCEPT	9
LOBBY	11
Design Goals	15
Luminaires and Equipment.....	16
Computer Rendering and Calculation	18
Lighting Plan	21
Evaluation	23
CONFERENCE ROOM	24
Design Goals	27
Luminaire and Equipment	27
Computer Rendering & Calculation.....	29
Lighting Plan	32
Evaluation	33
OFFICE.....	34
Design Goals	38
Luminaire Schedule	38
Computer Rendering + Calculation	40
Lighting Plan	43
Evaluation	45
FAÇADE	46
Design Goal.....	49
Luminaire Schedule	50
Lighting Plan	50
Rendering	51
Evaluation	51
architectural breadth.....	52

April 9th, 2014

4

DESIGN CONCEPT	53
DESIGN APPROACH.....	55
EXISTING FLOOR PLAN.....	57
FLOOR PLAN.....	57
RENDERING.....	59
structural breadth.....	60
OVERVIEW	61
EXISTING STRUCTURE.....	61
CALCULATION	62
electrical design.....	64
INTRODUCTION	65
CONTROL SYSTEM	65
PANELBOARDS and BRANCH CIRCUIT REDESIGN.....	67
SHORT CIRCUIT ANALYSIS.....	72
Depth: PHOTOVOLTAIC ARRAY.....	77
references	80
Appendix A	81
Appendix B	130
Appendix C	134

April 9th, 2014

building statistic

Building Name: Fraunhofer CSE Project <http://cse.fraunhofer.org/>

Location: 5 Channel Center Street, Boston, MA

Occupancy Type:

Offices and research laboratories (Group B) and conference room (Group A-3)

Size: 42150SF

Number of Stories above Grade: 6

Project Teams

Owner: Fraunhofer USA

General Contractor/Construction Manager: Gilbane Building Co. www.gilbaneco.com

Architects: DiMella Shaffer www.dimellashaffer.com

Structural Engineer: McNamara/Salvia, Inc. www.mcsal.com

MEP/FP/Tel Data Engineer: BR+A Consulting Engineers www.brplusa.com

Lighting Consultant: Lam Partners www.lampartners.com

Plumbing/HVAC Services: Northeastern Mechanical www.northeasternmech.com

Civil Engineer: VHB, Inc. www.vhb.com

Geotechnical Engineer: Haley & Aldrich, Inc. www.haleyaldrich.com

Dates of Construction: Jan 2012— Apr 2013

Architecture Design and Functional Component:

The project is a renovation for a 100-year old historical building of six-story, three-bay loft brick structure with classical revival-style detailing. The Fort Point Channel district is marked by an exceptional degree of visual uniformity. Fraunhofer Building, one of the buildings in the Fort Point Channel area, is not an exception of a loft structure built in 1913 by the Boston Wharf Company, and represent an unusually coherent and well-preserved collection of late 19th and early 20th century lofts that reflect a critical period of social, economic, and physical development in the City

April 9th, 2014

and the region. The loft buildings are generally masonry, with simple volumes and flat roofs. Buildings are elegantly proportioned, with classically inspired details concentrated at entrances and cornices. And the structure is left unchanged in this project to conserve the significant continuity throughout the District in terms of massing, scale, and style.

The majority of the structure has been left almost unchanged since its construction 100 years ago. In planning the renovations, CSE worked closely with the Fort Point Channel Landmark District Commission and National Park Service's Historic Preservation Planning Program, developing a retrofit plan that could deliver energy savings and still respect the building's historic character.

Applicable Codes

CODE TYPE	APPLICABLE CODE (Model Code Basis)
Building 780 CMR	Massachusetts Building code (8 th Ed.) (International Building Code 2009, amended)
Fire Prevention	527 CMR: Massachusetts Fire Prevention Regulations
ADA	Americans with Disabilities Act (2010 ADAAG), & Title II
FHA	Fair housing Act (Safe Harbor: FHA Design Manual)
Electrical	527 CMR 12.00: Massachusetts Electrical Code (2011 National Electrical Code, amended)
Elevators	524 CMR: Massachusetts Elevator Code
Mechanical	2009 International Mechanical Code
Plumbing	248 CMR: Massachusetts Plumbing Code (2005)

Zoning

Industrial District—Restricted Manufacturing: Planned Development Area Designation

<http://www.bostonredevelopmentauthority.org/zoning/downloadZone.asp>

Historical Requirement

The Fort Point Channel Landmark District Standards and Criteria (Design Guidelines, 2008)

<http://www.cityofboston.gov/landmarks/historic/fpc.asp>

Construction

This project is a historical building renovation and tenant fit-out. Gilbane Building Co. is the general contractor of this building and is responsible for the construction process of the Fraunhofer CSE building. The whole construction process lasts for over a year from January, 2012 to April, 2013.

Due to the special situation of the particular project, there is hardly an official estimate for the renovation. The almost all the building electrical, lighting and mechanical system as well as building material are donated from different manufacturers for the building technology showcase purpose

April 9th, 2014

of the building. The owner cannot provide an estimation number of this construction project. The delivery is not a regular method. It's a base building--tenant fitup process.

Electrical

There is a single electrical entry into the building providing power to the main distribution switchboard and the main fire pump. The electrical system of the building has a utilization voltage of 480/277V, 3 phase. Different utilization voltage is used throughout the building due to the variety of equipment needs in the building. The building emergency power system is powered by a 350kW, diesel filled, 480/277V, 3 phase, 4 wire standby emergency generator located on the rooftop. It provides the building with 120V emergency power for lighting and receptacles. There are 3 photovoltaic arrays on the rooftop inverting solar power to electric power for the building. There are pv panels mounted on the roof and west and east façades.

Lighting

The lighting design for Fraunhofer CSE building is energy efficient and sophisticated. The building is the project of the Fraunhofer building technology showcase. The lighting system donor provided the project the very up front. Most of the lighting fixture sources are LED and some are fluorescent source. A large amount of color changing LED is used in the building as well for the aesthetic purposes. The lighting systems work on both 277V and 120V system. Dimmable lighting fixtures are widely applied throughout the entire building. The lighting control system is connected to BAS system. Shading system is installed in the building as part of a daylight control system.

Mechanical

There are 2 boilers to reheat/preheat the hot water, 4 pumps for roof hot water service and basement fuel oil supply. There are two air handling units locate on the roof serve for building ventilation and exhaust. They work on 460V, 3 phase motors. The AHU supply air quantity to be 20,000 CFM. And its cooling coil load is based on 100% CFM and the preheat coil load sized for 75% CFM preheat coil sized for 100% outside air at 0°F. High efficient active chilled beams are used in the building to supply heating and cooling air. The building also utilizes in-floor radiant heating cooling system on 1st and 3rd floor for additional heating and cooling. 11 water pumps are located on different levels in the building supply for chilled water, condenser water and chilled beam water.

Structure

The building is a three-bay loft steel frame structure. All columns are the existing steel columns with existing concrete column bases. The typical bay spans as long as 20ft. The main wall structure is masonry, brick wall with metal studs. The floors are existing typical wood decking with glass fiber reinforced concrete on top and the roof is existing wood deck and concrete slab. The building is a 100-year-old historical building so the typical beams sizes are hard to be obtained at the point.

lighting design depth

In the lighting depth, there are four spaces being redesigned are

Lobby | circulation space

Conference room | special purpose space

Open office | large work space

Façade | exterior space

The design concept for this a-hundred-year old historical building is developed through the company profession which is clean, intelligent and corporative.

April 9th, 2014

INTRODUCTION

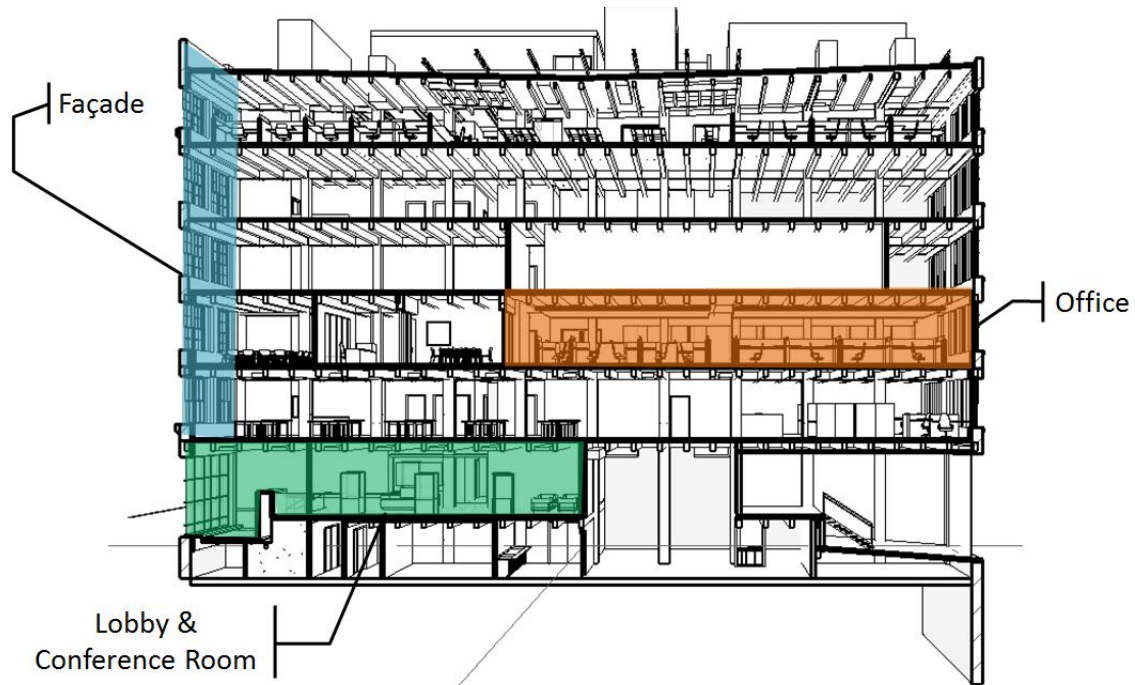

Figure 1

The design concept is extracted from the company profession that they want to advertise to the public and the related industry about clean energy, intelligent building system and collaborative research on sustainable material. From there I concentrate the main design ideas to be clean, intelligent and collaborative. From those ideas, the design of four spaces will mainly contains linear or simple line lighting patterns that will create a modern and technological look in the spaces like those typical appearances in the sci-fi movies. The lighting will create layers in the space to help emphasize the architectural features in this classical style building so to collaborate the modern and classic style together.

DESIGN CONCEPT

The general idea of the concept is to create the modern look of the building also with the idea of presenting the company image of high-end and environmental-friendly. And the design could also really help the people who stay in the space to enjoy the time and work with good mood. To incorporate this idea, some images I found could be a great way to show the concept and the driven idea when comes to the fixture selection and layout planning.



Figure 3



Figure 2

These images represent the look I'm trying to go for in the lighting design. Straight continuous lighting pattern will be the dominant look in all the spaces. The design is trying to make people working in the space could enjoy the refreshing look of the company during the daytime.

April 9th, 2014

LOBBY

Space Description

The lobby is located on the ground floor/first floor on the north side of building. The lobby consists of two parts with two different floor heights. The lower part of the lobby with a small floor area serves as a transition area from vestibule to the reception area. The upper level of the lobby is the main reception area which is the designated design area for the depth. The two parts are connected by a short length of stair and a short wall with the company name on. The north side of the lower portion is the north wall of the building with large window area. A convertible partition glass wall is on the longitude side of the upper portion lobby separating the lobby and the large conference room. The south side of the lobby is the overlook window to the PV lab in the basement. A specially designed reception desk is on the upper level facing the large conference room. For plan see *Figure 4*.

The primary tasks of the lobby are reception, circulation and showcase. The company is currently under the discussion of putting some touch screen table and display closets for future showcase purposes. By removing the movable wall between the large conference room and reception area, the large area can serve as a gallery for new products exhibition.

Room Dimension

Width: 19'-10"

Length: 47'-8"

Height: 8'-10 ¼

Room Finishing/Glazing

Table 1

	SURFAC E	MATERIALS	FINISH	DESCRIPTION	REFLECTANCE
Upper Lobby (Reception) F113	Floor	Rubber	RBT-1,2,3	Three color rubber finishing on 2 layers of ¾" ply wood subfloor	0.4, 0.7
	Wall	GWB/Glass	PT-1,ACC	5/8" GWB, 3 5/8" Mtl. framing furring wall/ Dorma Moveo moveable wall	0.94
	Ceiling	Timber, act panel	PT-1,3,4	Exposed beams, acoustical panel	0.8

April 9th, 2014

Architectural Drawings of Existing Design

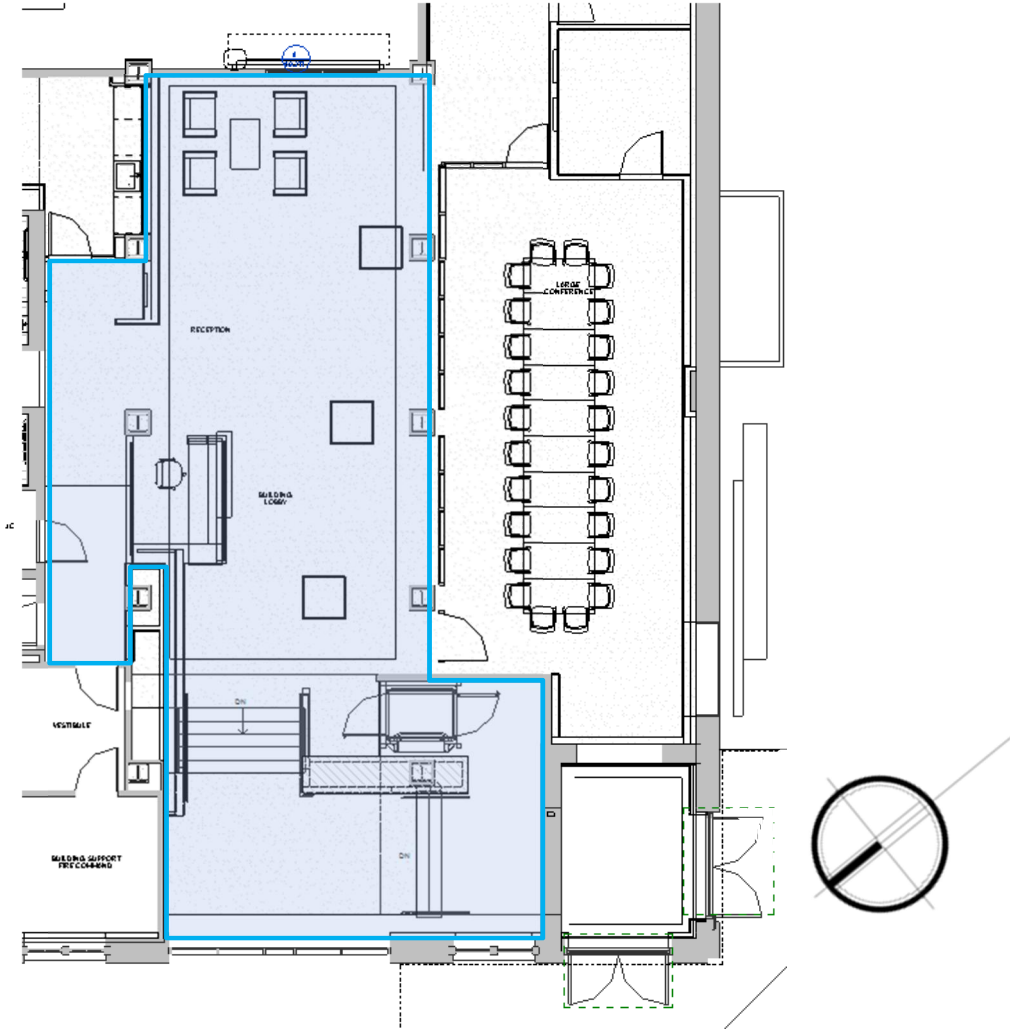

Figure 4

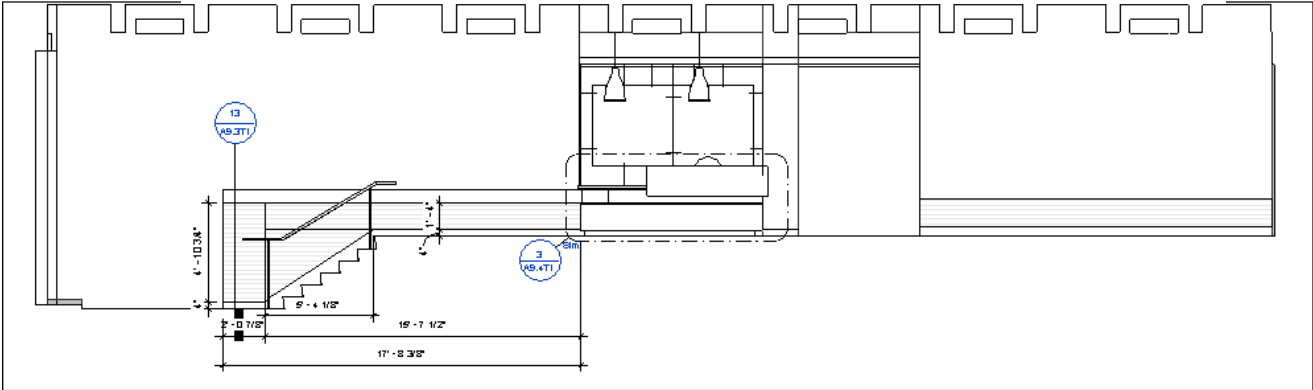

Figure 5

April 9th, 2014

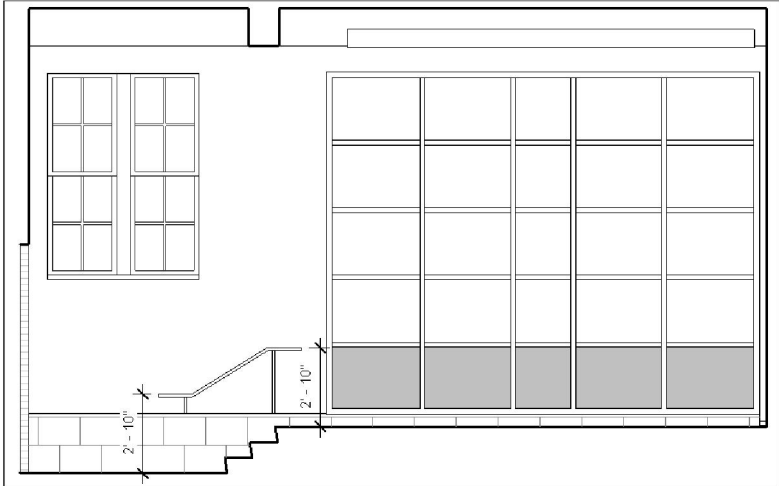

Figure 6

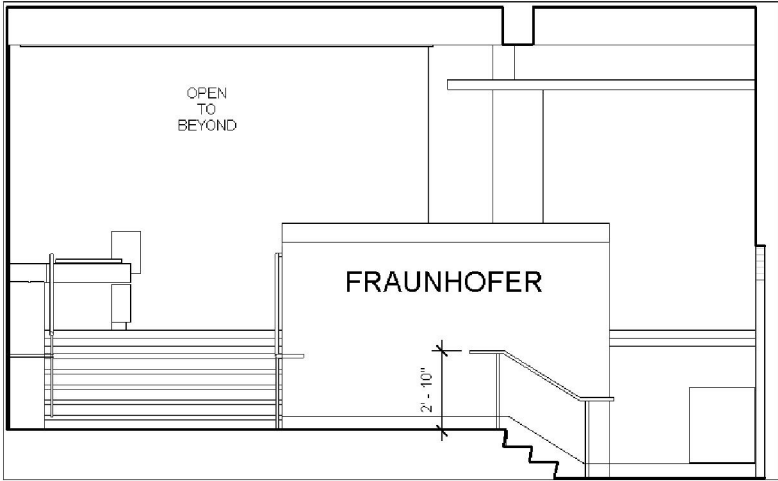

Figure 7

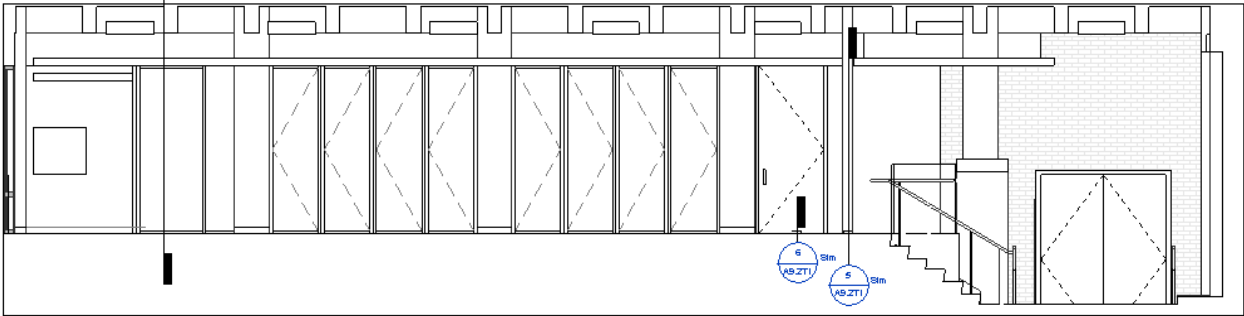

Figure 8

April 9th, 2014

Lighting Design Criteria & Consideration

Lobby is the space where people gather. This lobby is a part of the entry passage of the building. It directly connects the vestibule. Therefore the lobby area presents the company image in a very crucial way. The color rendering and uniformity are two priority issues that needed to be considered. Also, since this space will also be used as a showcase/gallery area, aesthetic appearance plays a very important part in this space. More kinetic and high-tech lighting design should be considered of use to help improving the visual representation of the space. The reception desk area should be specially considered due to the fact that writing and reading tasks will be conducted in the reception area. The space should be designed with the consideration of the conference room design, because the two spaces are designed to have the possibility of joint use as an open exhibiting space. The location of the lobby decides that there isn't much daylight available in the space, so most lights will be on during large portion of time during the day, so energy efficient fixtures are the better choice when dealing the fixture selection.

IES Illuminance Recommendation

Table 2

Space		Eh	Ev	Avg:Min
Upper Lobby (F113)	Reception Desk	150 lux	50 lux	4:1
	General Area	100 lux	30 lux	4:1

ASHRAE 90.1 (2010) Requirements

Power Density Allowance: 0.90 W/sf

Control requirements: The space shall have automatic shutoff control. The control shall be schedule basis or controlled by other signal from building automatic system. The automatic control device shall be manual on or automatically turn lights on to 50%.

Accenting

The main goal for the lobby is for congregation and orientation. And accenting is used for visual attraction and way finding.

Appearance and Aesthetic Consideration

April 9th, 2014

Use the lighting effects and layouts to reinforce the form and neutrality of the architecture. The illuminance and uniformity decide the people's satisfactory of the space. Those are some critical issues for an entrance space like lobby.

Color Quality of Light

Color rendering affects people's sense of perception of clarity and visual comfort. Good color appearance is important for the entrance space like lobby. Lamps with CRI of about 80 will be considered a better option of fixture selection.

Glare

Controlling glare from luminaires is essential to maintain occupant visual comfort. By selection luminaire with sufficient optics and install with the right aiming angles will reduce the glare to the minimum.

Installation and Maintenance

The installation in the lobby requires some minor finish changing of the original space. Ceiling panels and column finish needs to be changed with the new design solution in order to realize the recessed luminaire along the ceiling and the columns.

Controls and Flexibility

The lighting can be controlled in different zone groups for dimming purposes. Unless the space is joined with the conference room, no multi-scene is needed for the general purpose.

Design Goals

As the gateway of the company, lobby plays an important part of representing a company's image. With this thought in mind, of all the designs for the four spaces, lobby has the most sophisticated design and it contains the most features to showcase the design concepts. The lobby is on the first and connecting the lower level vestibule with two sections of short length staircases with a landing in between. The upper level lobby is the reception area. There are multiple layers created in the lobby and the layers helps defining the shape of the space. Linear lighting fixtures

April 9th, 2014

that highlight the columns to the beams are the main feature of the space. Those linear white lights make the space has a feeling like in the sci-fi movies. Warm colored indirect light from in between the beams are used to add up the layers above the exposed ceiling structures. The light hide beneath the stairs helps define the transition areas and leading people into the space. The logo wall by the landing next to the stairs is combines with light fixtures and helps emphasizing that the company's profession is about technology.

Luminaires and Equipment

In order to reach the goal of energy efficient design, when selecting the fixtures, the goal is to minimize the wattage consumption and reach the desire illuminance level.

Luminaire Schedule

Table 3

TYPE	#	DESCRIPTION	MANUFACTURER	MODEL	LAMP	WATTS	VOLTS
L1	31	Recessed 6" wide seamless linear dimmable LED light with acylic lens	PRULITE	BIO-SM-06-SAL-YGW	LED	19.2	277
D2	16	Wall surface mounted 3" square downlight	Edison Price	LED-SQ-XSM-DL4-1000	LED	18.66	120
L4	34	Recessed 2.5" wide continuous linear white-LED light with 1.6" diffuser lens	Pure Edge	TL1.6-5WDC-3FT-24K-WH	LED	18.55	120
P1	1	Pendant mounted 4' diameter round white LED circular light with constant voltage driver	DELRAY	6704-S-W41	LED	48.6	120
L5	144'	Continuous LED dimmable light strip mounted inside a square clear or frosted acrylic channel	Dreamscape	DLED-5400	LED	2.5/ft	24
L7	5	Surface mounted white LED strip light with 3000K color temperature	Bartco	ECO5-JP-3-35F	LED	5.7	120

April 9th, 2014

Table 4



L1



P1



D2

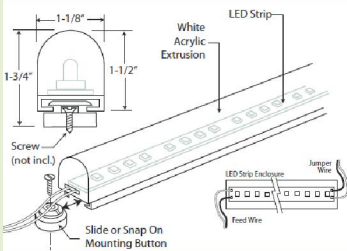

L5



L4



L7

Light Loss Factors

All LED lamped luminaire are assumed to have a LLF of 0.7.

April 9th, 2014

Computer Rendering and Calculation

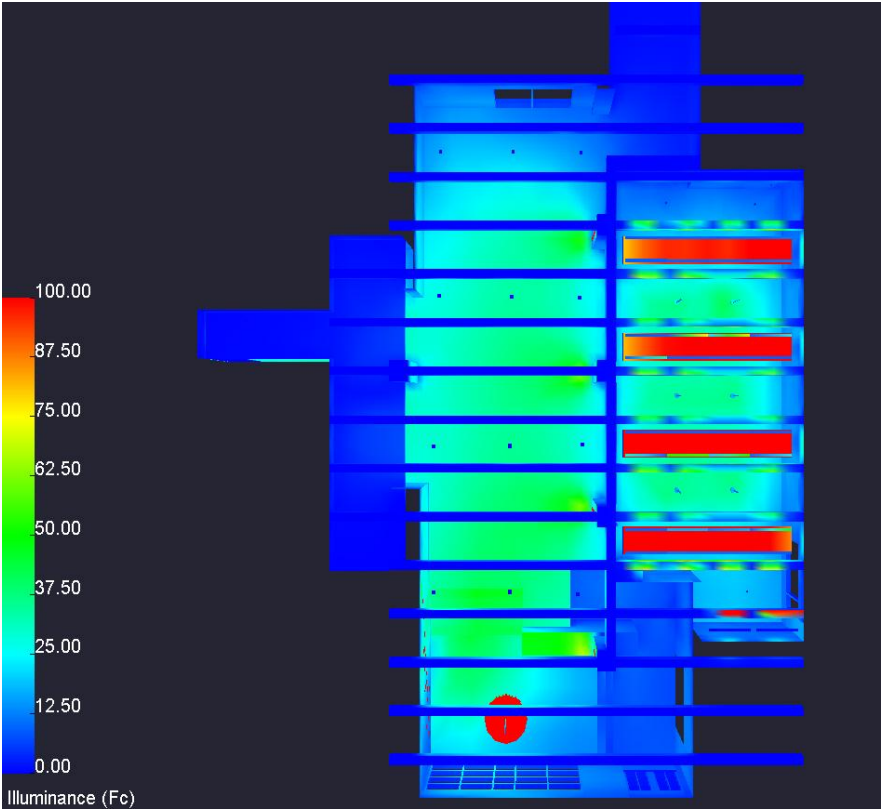

Figure 9

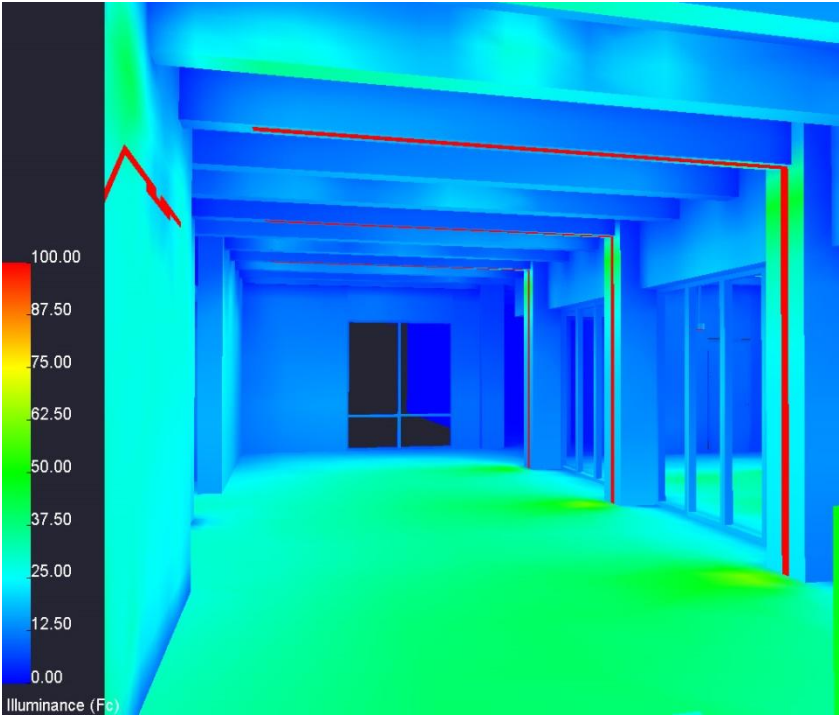

Figure 10

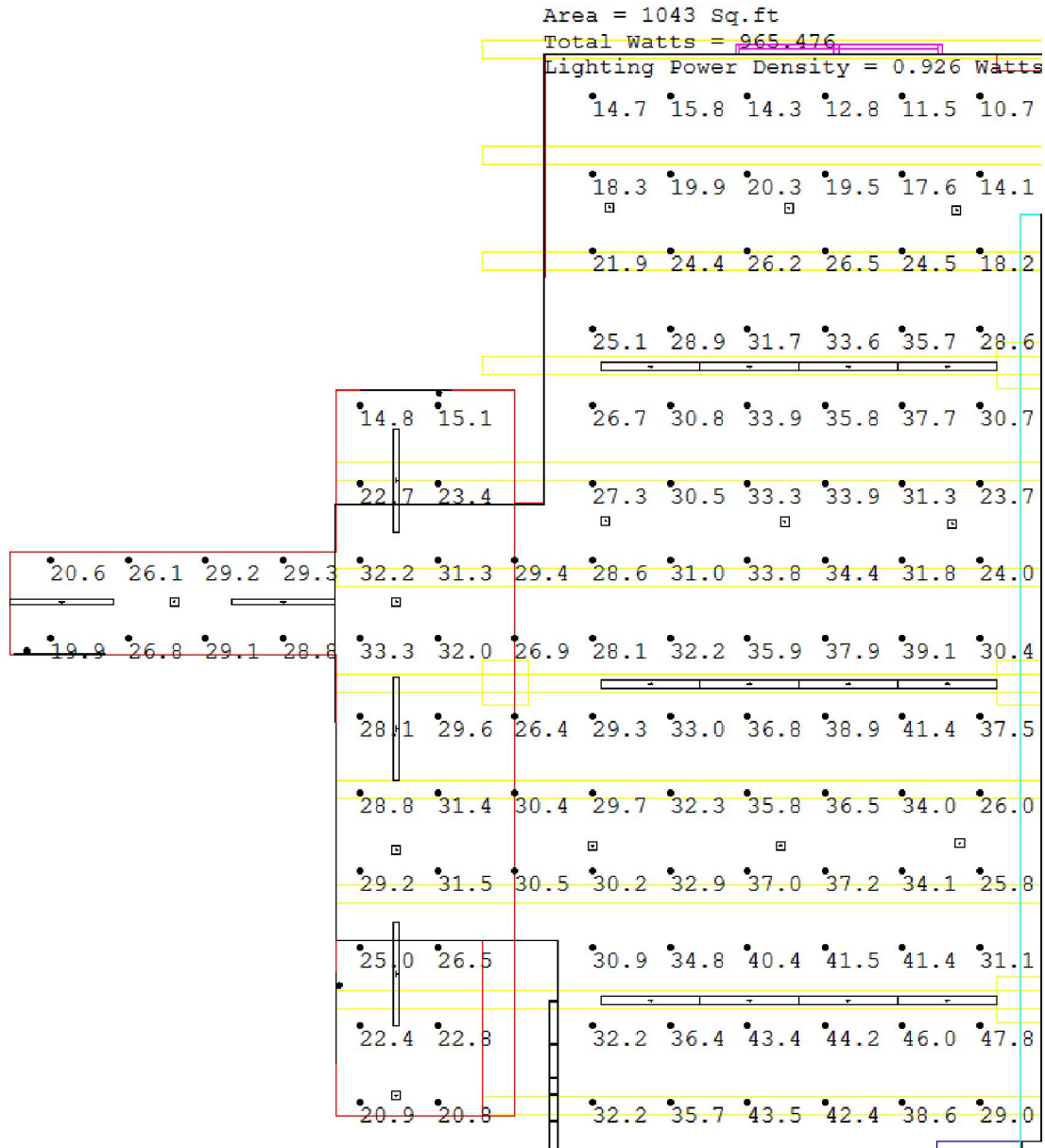

Figure 11

Project 1
Calc Pts

Whole

Illuminance (Fc)
 Average=29.57 Maximum=47.8 Minimum=10.7
 Avg/Min=2.76 Max/Min=4.47

LPD-UWLR Areas

Lobby LPD

Area(Sq.ft)=1043 Total Watts=965.476 LPD
 (Watts/Sq.ft)=0.926

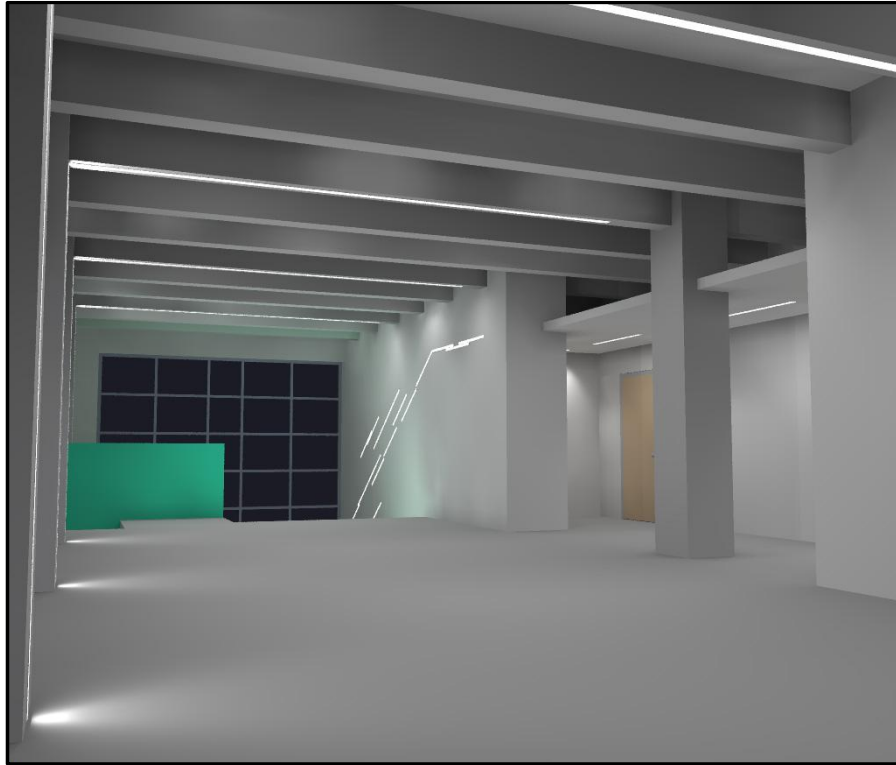

Figure 12

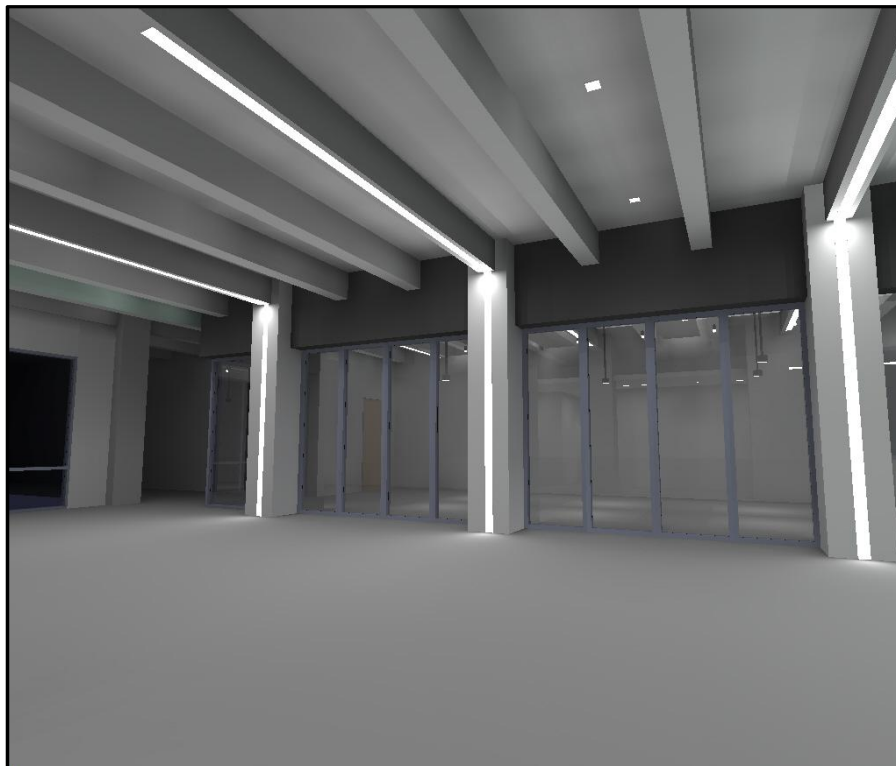

Figure 13

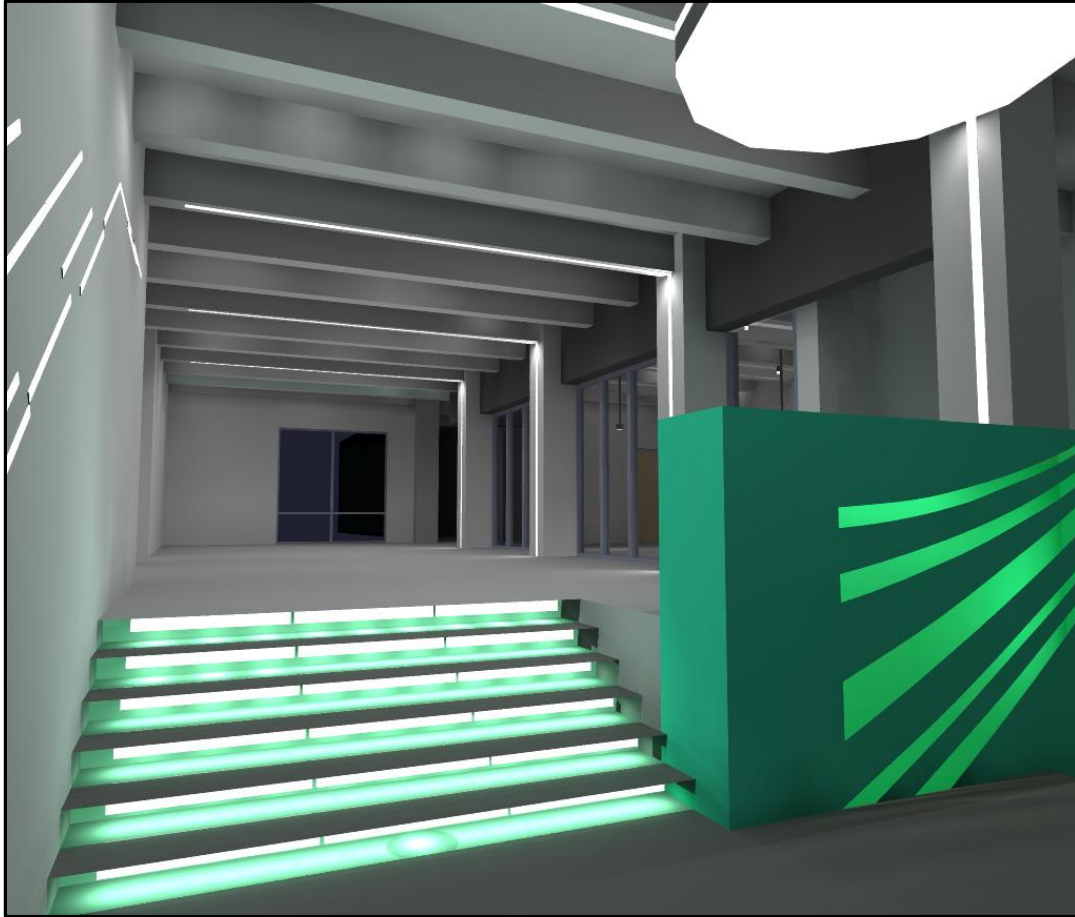
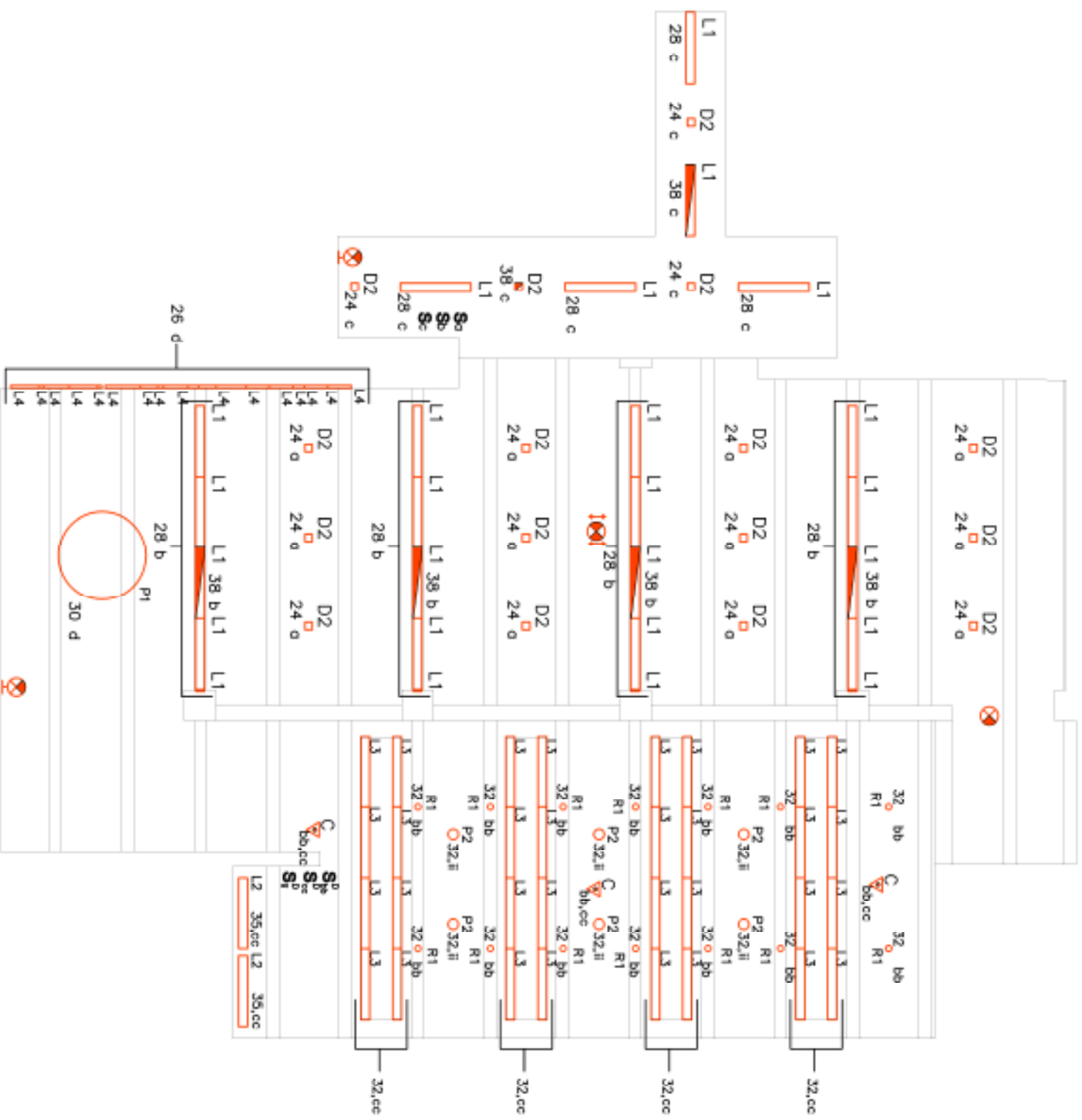

Figure 14

Lighting Plan



5/32"=1'-0"

PROJECT:
 FRAUNHOFER CSE

CONTENT:
 LIGHTING PLAN
 LOBBY
 CONFERENCE RM

DRAWN BY
 XIAOYIN WU

DATE:
 APR 2014

April 9th, 2014

Evaluation

The lobby lighting design main goal is to provide general illumination for the psychological impression of modern and techno feeling. The new lighting design style brings more scientific fictional impression into the space. It achieves the goal of making a good first impression to the people entering the building for the first time.

The continuous linear fixtures that are installed along the columns and beams helps define the space volume. The downlights that are placed in between the beam grooves help make the entire space uniformly lit up.

Lobby has an average illuminance of 29fc and max:min ration = 4:1. The average value exceeds the IES criteria. But this is a space dedicate for a more decorative and image display function of the building. So the illuminance criterion becomes a less important factor in the design consideration.

April 9th, 2014

CONFERENCE ROOM

Space Description

The large conference room is a rectangular shaped room on the first floor locates right next to the lobby. The conference room is separated from the reception area by a movable petition glass wall which can be removed and converts the first floor into a large open space. The conference room is also served as a multi-function work space if needed. There is one small window of the west façade.

Room Dimension

36' x 16' 8" x 8'-10 ¼" (L/W/H)

Room Finishing/Glazing

Table 5

SURFACE	MATERIALS	FINISH	DESCRIPTION	REFLECTANCE
Floor	Carpet/Rubber	RBT-3/CPT-1	Dark color carpeting on 2-color rubber finish	0.3, 0.7
Wall	GWB/Glass	PT-1,2,4	5/8" GWB, 6" Mtl. framing furring wall/ Dorma Moveo moveable wall	0.94, 0.6
Ceiling	Timber, Acoustical Panel	PT-1	Exposed beams, acoustic panel	0.8

Architectural Drawings of Existing Design

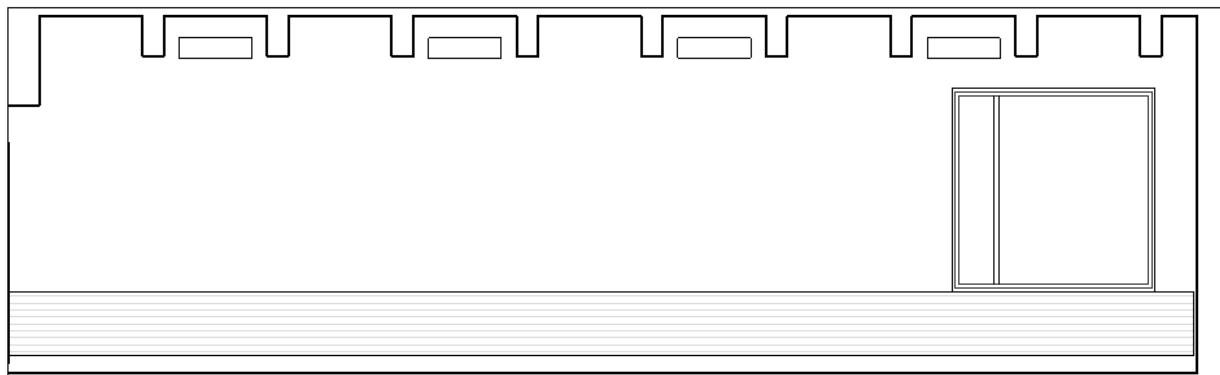

Figure 15

April 9th, 2014

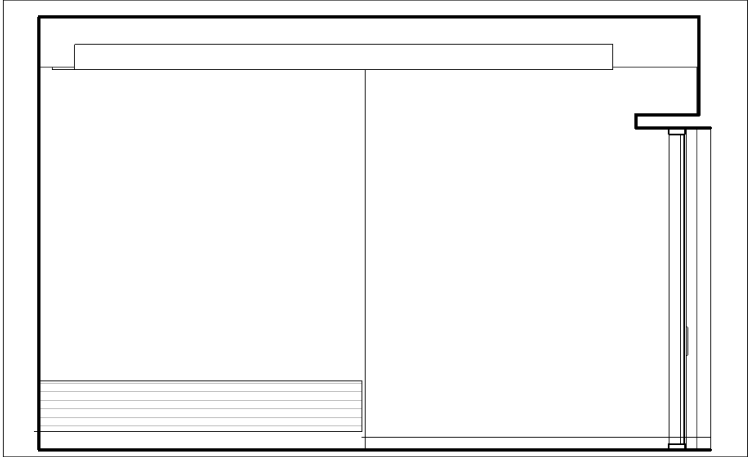

Figure 16

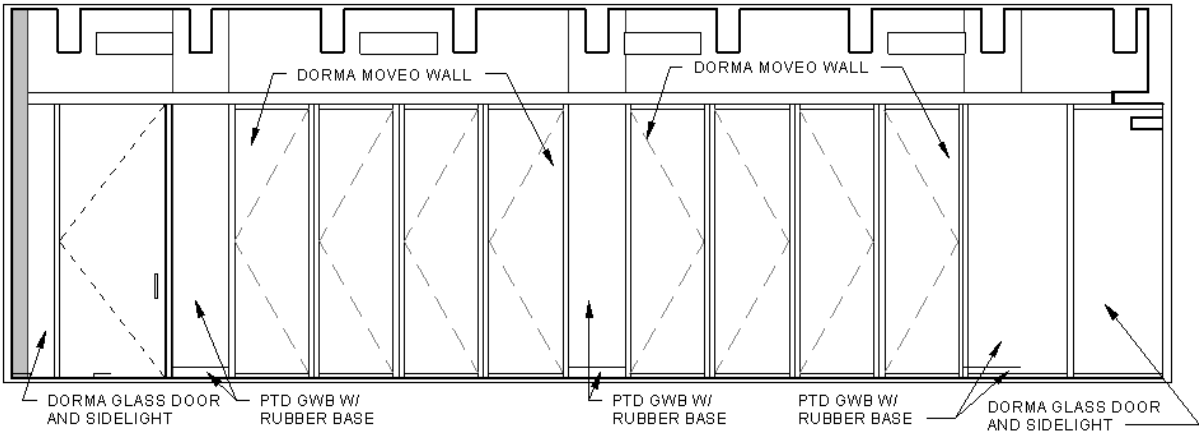

Figure 17

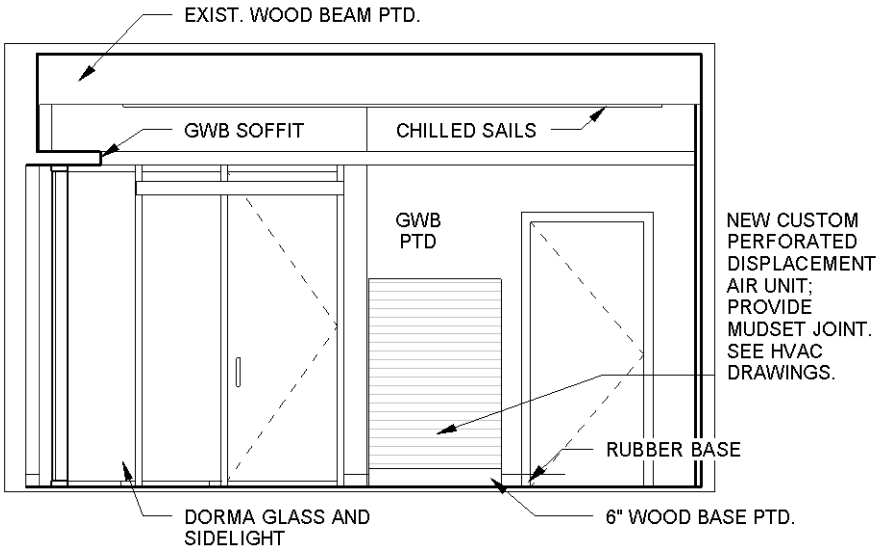

Figure 18

April 9th, 2014

Existing Furnishing

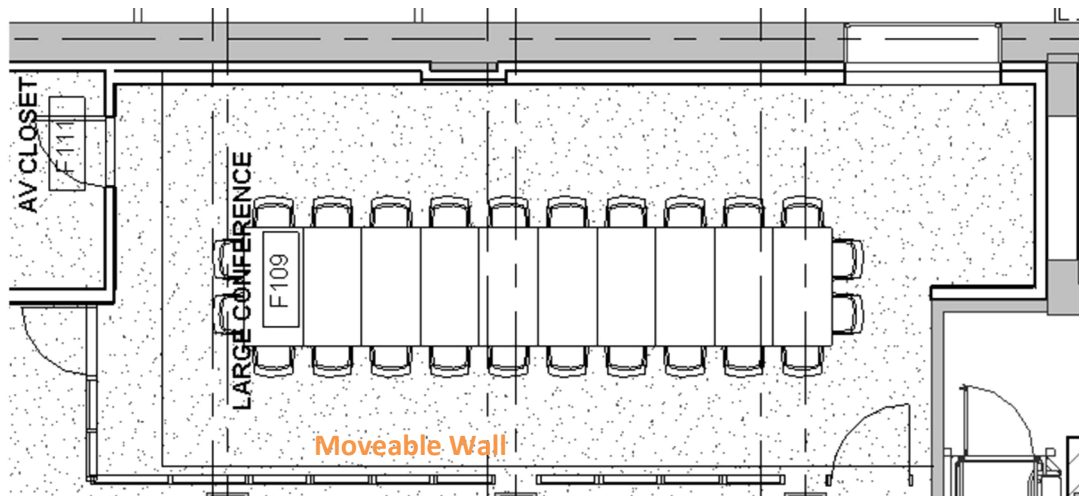

Figure 19

Lighting Design Criteria & Consideration

IES Handbook 10th Ed. Recommendation

Table 6

Surface/Purpose	Eh	Ev	Avg:Min
Meeting	150	75	1.5:1
AV	30	30	
Front-screen projection		50	
Faces	300	400	1.5:1

ASHRAE 90.1 (2010) Requirements

Lighting Power Density = 1.23 W/sf

Control requirement will be discussed in detail in the electrical depth section of this report.

Appearance and Aesthetic Consideration

Lighting layout that highlighted the architectural features will make the space look spacious and brings view pleasure to the people in the space.

Flicker

Flicker can distract and bother the users in the space. It is very essential that the work space is flicker free to provide a comfortable working environment.

April 9th, 2014

Light Distribution

Lighting should be functional and can addresses qualitative factors affecting users' work performance. For the task driven oriented space, sufficient light level across all the work planes is critical in the office space.

Reflected Glare

Veiling reflecting is important issue due to the reading and writing will be the major tasks in the space. And lighting design shall minimize the reflection and glare in the space.

Shadows

Shadows shall be eliminated to provide an evenly lit-up space in order to create a spacious feeling in the office.

Controls and Flexibility

Conference room shall be controlled with multi-scene lighting configuration. Because the conference room may serve different types of meeting with varies purposes, such as presentation, meeting, AV, etc. So the control system will be designed in accordance with this goal.

Design Goals

The conference room is a special purpose space. It is essential that the lighting design reach both task oriented purposes as well as aesthetic visual comfort. Different approaches, like both direct and indirect lights lighting shall be used to provide varies lighting condition along with different light levels and aiming angles.

Luminaire and Equipment

April 9th, 2014

Luminaire Schedule

Table 7

TYPE	#	DESCRIPTION	MANUFACTURER	MODEL	LAMP	WATTS	VOLTS
L3	32	Ceiling surface mounted linear strip LED lighting with 3000K color temperature	WINONA	WSL-106-4-30-30K	LED	25.1	120
R1	14	Surface mounted 3000K warm white LED wash light with cylindrical light head	ERCO	71015.023	LED	6	120
P2	6	Pendant mounted task downlight with bronze sconce decorative shade	LITHONIA	MWS C BZ WITH DMCN BZ SHADE	LED	9.9	120
L2	2	Recessed white LED wall washer with frosted lens for glare free lighting	FINELITE	HPW-FR-LED-3500K	LED	37	120

Table 8

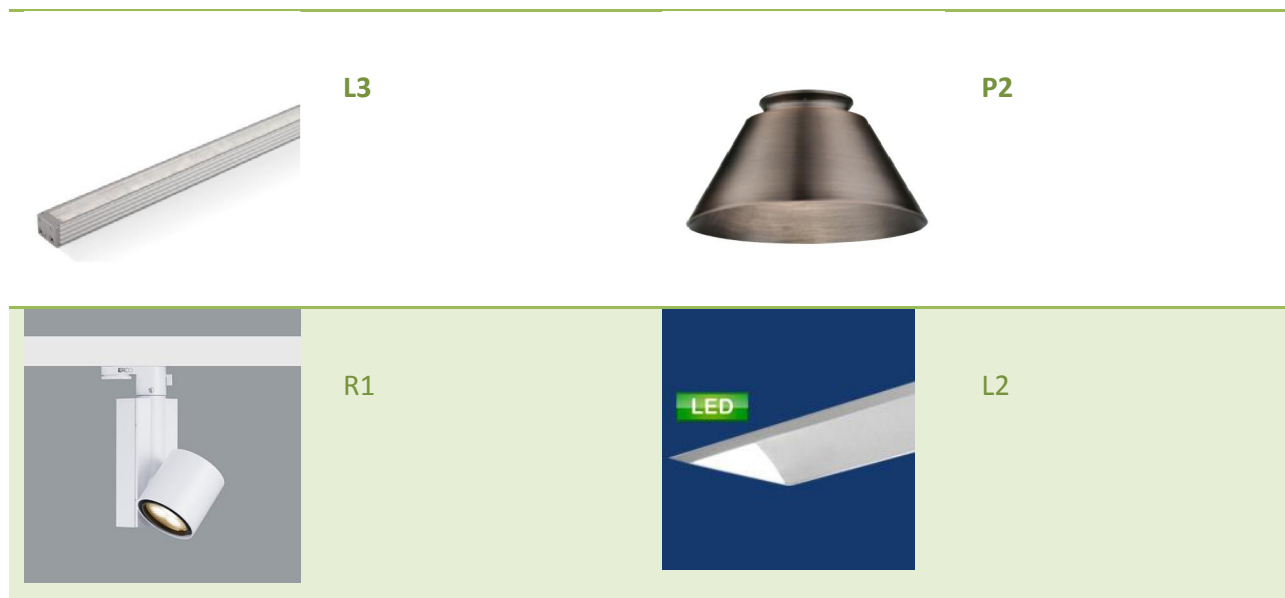

April 9th, 2014

Control Schedule

Table 9

	LEBEL	#	MANUFACTURER	MODEL	TYPE	WATTS
	C	3	WATTSTOPPER	UT-305	Ultrasonic	120

Computer Rendering & Calculation

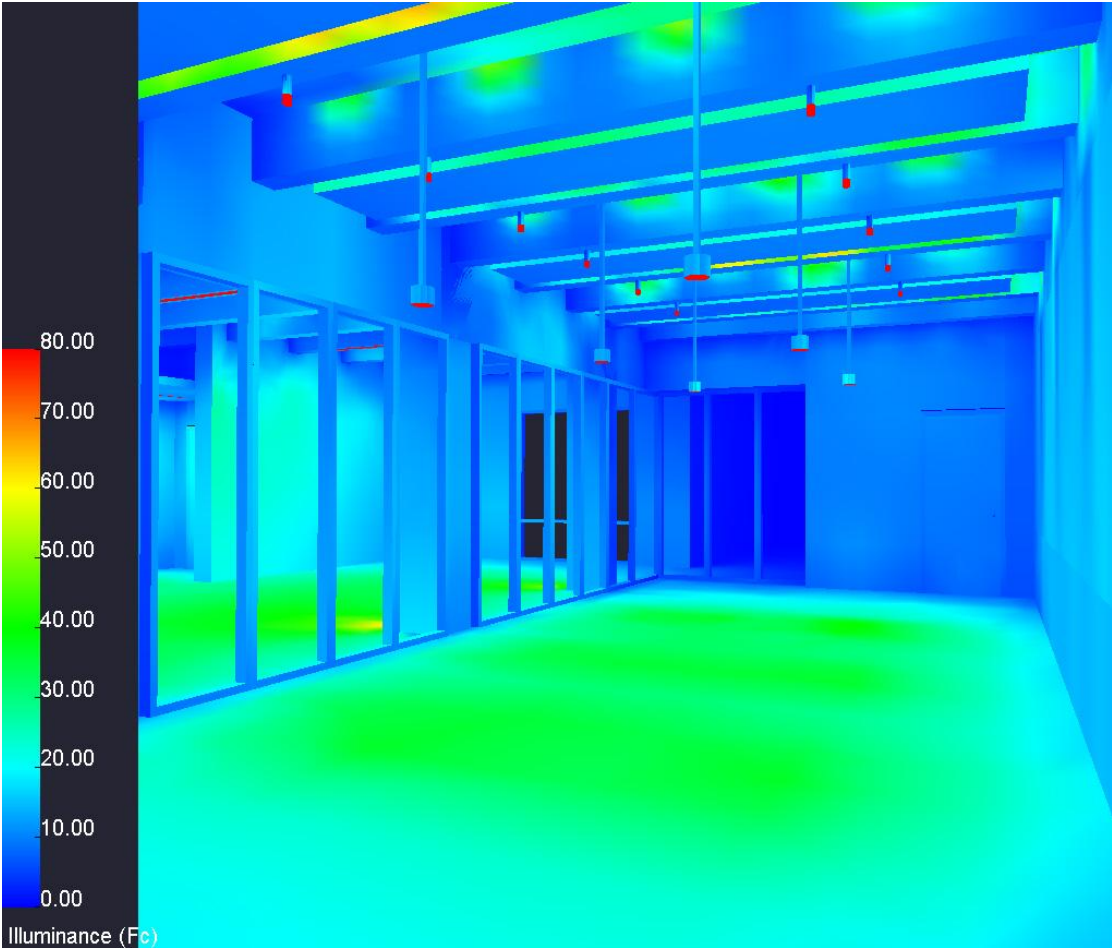

Figure 20

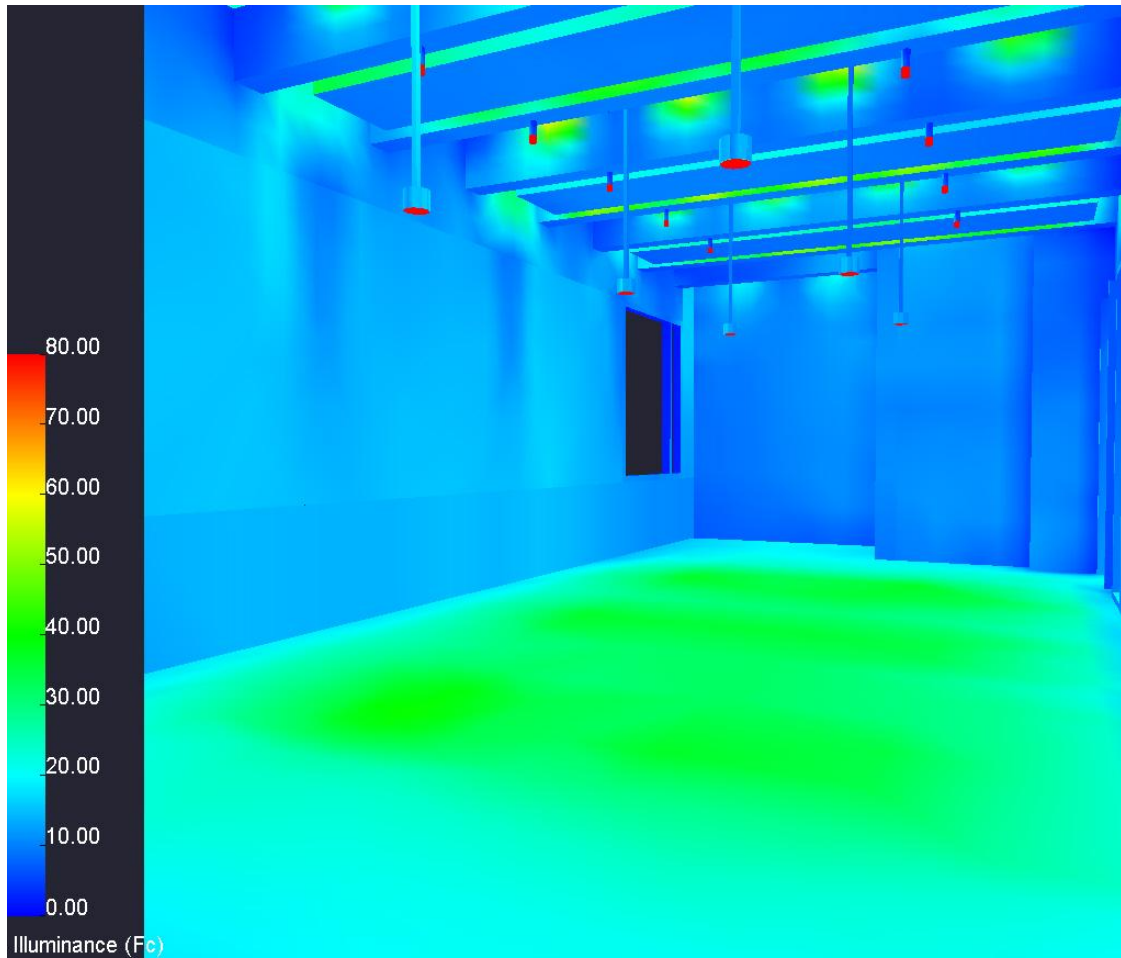

Figure 21

April 9th, 2014

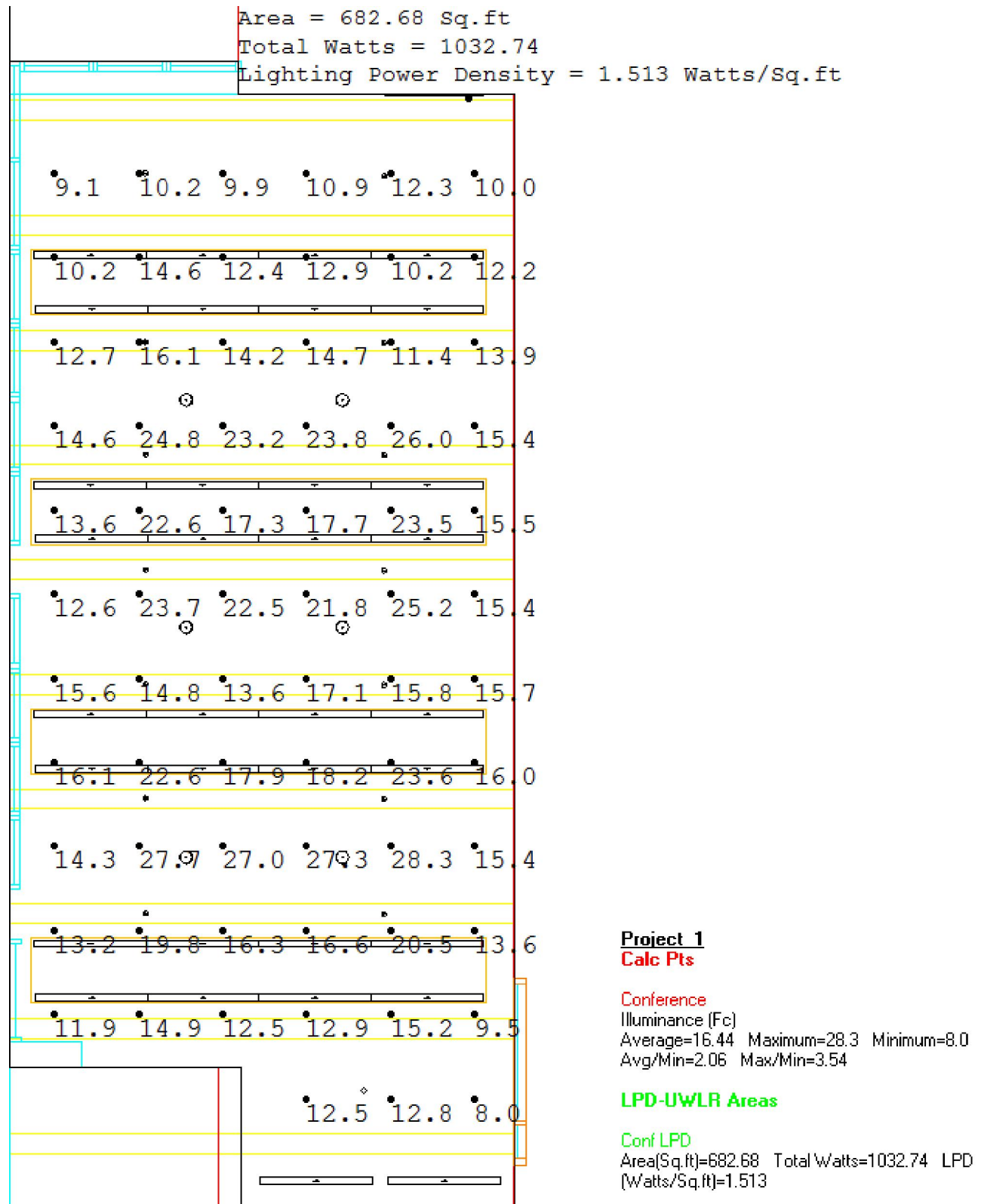

Figure 22



Figure 23

Lighting Plan

See the same lighting plan in the Lobby section on Page-22.

April 9th, 2014

Evaluation

In order to incorporate the ceiling acoustic panels laid between the beams in the conference room. The indirect lighting serves as the accenting lighting. But the high output result in high wattage consumption. And the Lighting Power Density is 1.5W/sf which exceeds the ASHRAE 90.2 requirement of 1.23W/sf. Although the rest of the building low LPD will make up to this. The pendant luminaires are designed to be the task lighting mainly for the writing and reading purposes on the work plane, while the spotlights are placed in two rows for washing the vertical surfaces and the people's faces. By washing the vertical surfaces instead of directly lighting up the space gives the space an evenly distributed lighting effect and also helps reduce the direct glare to the minimum. Besides that, when the removable walls are removed between the lobby and the conference room for the showcasing and exhibition purpose, the aiming angles of the spot lights can be adjusted to serve that task very efficiently.

April 9th, 2014

OFFICE

Space Description

The open office on the third floor takes up most of the floor area. It's a narrow rectangular shaped area locates in the center of the floor space. This open office space is surrounded by private offices and labs, except on the building east side. The east side of the open office area is directly against the exterior wall which has three big windows with shading system. A small conference room with complete glass partition is on the west side of the office area right in front of the 3rd floor reception area. The private offices and labs are located along the outer side of the floor, most with glass front facing the open office area. And the cafeteria is by the reception area on the west side corner.

Room Dimension

102' x 33' 8" x 10' 7"

Room Finishing/Glazing

Table 10

SURFACE	MATERIALS	FINISH	REFLECTANCE
Floor	Rubber	RBT-1,2,3	0.3, 0.7
Wall	GWB Glass	PT-1,2,3,4	0.94, 0.5
Ceiling	Exposed timber beam, Acoustical panel	PT-1/AC T-1	0.8

Figure 3.1-Existing furnishing plan

MA

April 9th, 2014

Architectural Drawing of Existing Condition

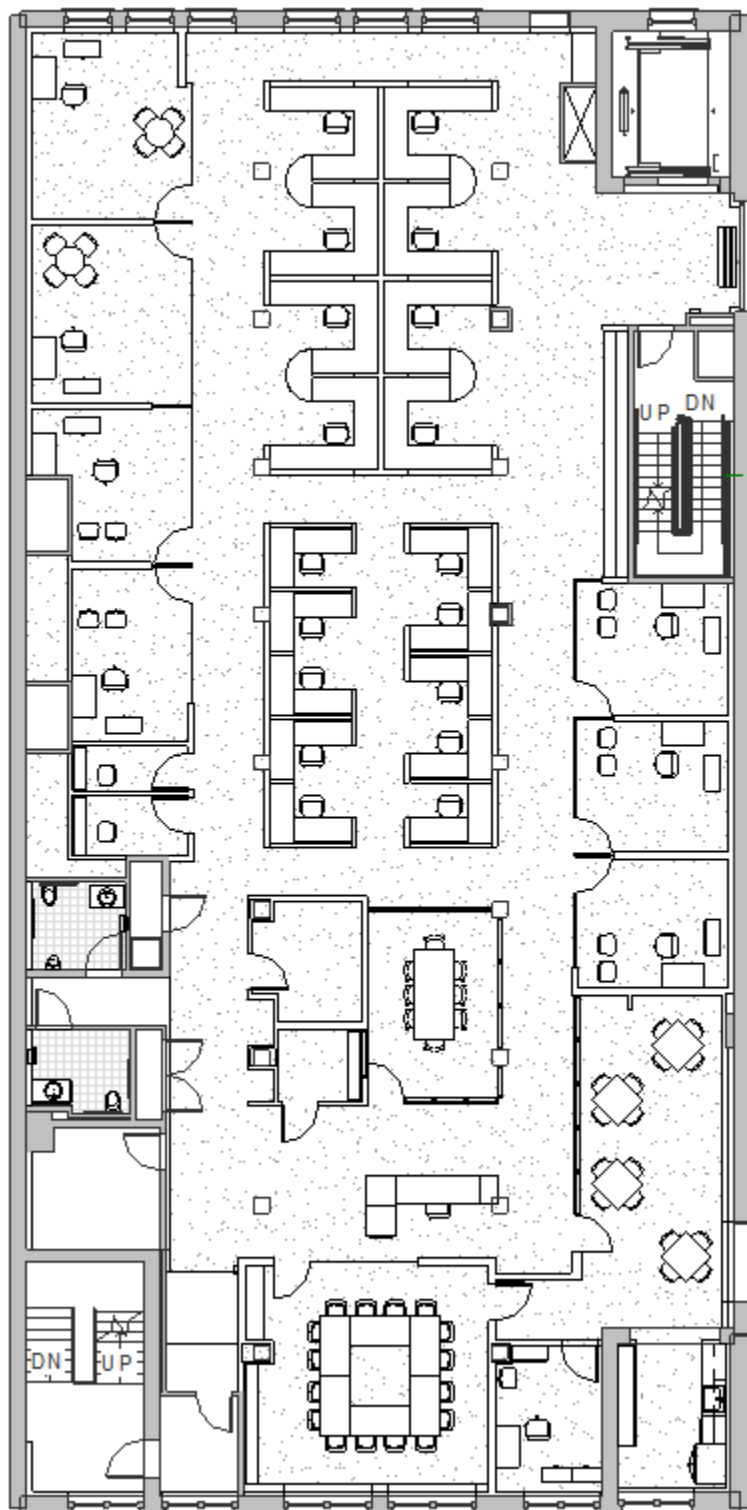

Figure 24

April 9th, 2014

Lighting Design Criteria & Consideration

The open office is a work space. So uniformity is one of the most important issues that will affect the lighting performance. Also, energy is a very important factor of a good lighting design. As for a company like Fraunhofer that dedicates into energy saving building technology, it is especially crucial to present a very environmentally friendly lighting/control system. Smart lighting system with dimmable luminaires and automatic control system need to be used. The control system should be able to automatically adjust light level according to vacancy status and daylighting condition as well as automatically shut lights off when necessary according to codes.

IES Illuminance Recommendation

Table 11

Surface/Purpose	E _h	E _v	Avg:Min
Work plane (computer)	150	50	1.5:1

ASHRAE 90.1 (2010) Requirements

Lighting Power Density Allowance = 0.98 W/sf

Control Requirement:

- Automatic shutoff control device is required to shut off building lighting in all spaces
- Automatic control device is required to manually turns light on or automatically turns light on to 50%
- Multi-level control is required to have at least one control step between 30% and 70% of full lighting power in addition to all off
- Potential auto daylighting control for primary sidelighted areas is required if the combined primary sidelighted area in the space is equal or exceeds 250sf
- Additional lighting control for special purposes and multi-scene control will be needed if applicable

Accenting

In work space, accent lighting minimizes the fatiguing effects of long-term close-up viewing of tasks and provides visual relief by addressing luminance aspects. Additionally, accent

April 9th, 2014

lighting addresses some special and psychological factors. In the office space, ambient lighting is the most crucial way of lighting, however, accent lighting for certain surfaces can make the interior space more defined and visually attracting.

Appearance and Aesthetic Consideration

Lighting layout that highlighted the architectural features will make the space look spacious and brings view pleasure to the people in the space.

Flicker

Flicker can distract and bother the users in the space. It is very essential that the work space is flicker free to provide a comfortable working environment.

Light Distribution

Lighting should be functional and can addresses qualitative factors affecting users' work performance. For the task driven oriented space, sufficient light level across all the work planes is critical in the office space.

Maintenance and Installation

In the newly design office space, it will be harder to maintain the lighting scene as the ceiling height raised compare to the previous design. The layout is slightly trickier than the original design as well.

Reflected Glare

Veiling reflecting is important issue due to the reading and writing will be the major tasks in the space. And lighting design shall minimize the reflection and glare in the space.

Shadows

Shadows shall be eliminated to provide an evenly lit-up space in order to create a spacious feeling in the office.

Controls and Flexibility

April 9th, 2014

Different areas in the office are controlled separately with occupancy sensors and control systems. It is critical for the purpose of energy saving.

Design Goals

The goal for the office lighting design is to improve the working environment and truly promote the technology supported lighting design. Different types of lighting features and clean-line lighting elements coordinates smoothly together helps redefine the space. The original open office is a small narrow space with very low ceiling level and exposed HVAC system. The lighting design for this condition is aimed to help creating a spacious feeling and make people who work in there will be able to enjoy the working experience for the company. The proposed design for this space is to open up the ceiling in the center bay to the upper floor (which is current vacant and under design process for future use). With this change, it expands to a much larger volume and provides the space much larger room for creative lighting design. The lighting will help celebrate the architectural features while create a high-end modern office look. Refreshing and spacious feeling will be the main concept of the design in the office with simple line lighting fixtures. Indirect lighting together with washing or grazing method will help define the space, as well as create layers so that all features collaborate together for the whole image of the look. . At the same time, more decorative lighting is used to provide a more dynamic looking and the changing views from different perspectives in the same space. Washing fixtures are largely used to redefine the shape of the space. The high illuminated surfaces create an even more spacious impression. With the help of increasing the ceiling height, more day-lighting will be coordinated within the lighting design.

Luminaire Schedule

Table 12

Type	#	Description	Manufacturer	Model	Lamp	Watts	Volts
P3	16	Suspended linear 2.5" diameter tube with fluorescent lamping and acrylic lens enclose	SPI-STILE	SIP11575-2F28	2FT5	57.5	277
L6	16	Surface mounted white LED tube cover light with iron phosphate pretreatment casing	COOPER	SNLED-LD1-32-UNV-L840-CD1-U	LED	28.4	120

April 9th, 2014

L2	32	Recessed white LED wall washer with frosted lens for glare free lighting	FINELITE	HPW-FR-LED-3500K	LED	37	120
L1	69	Recessed 6" wide seamless linear dimmable LED light with acrylic lens	PRULITE	BIO-SM-06-SAL-YGW	LED	19.2	277
D1	9	4" recessed LED downlight with anodized aluminum reflector	JUNO-INDY	L4-1530+L400HW-CL	LED	8.7	120
R2	12	Pendant 6" diameter white LED downlight with extruded aluminum cylinder body	PRESCOLITE	LD6LED4P	LED	28	277



April 9th, 2014

Control Devices Schedule

Table 13

	LEBEL	#	MANUFACTURER	MODEL	TYPE	WATTS
	C	10	WATTSTOPPER	UT-305	Ultrasonic	120

Computer Rendering + Calculation

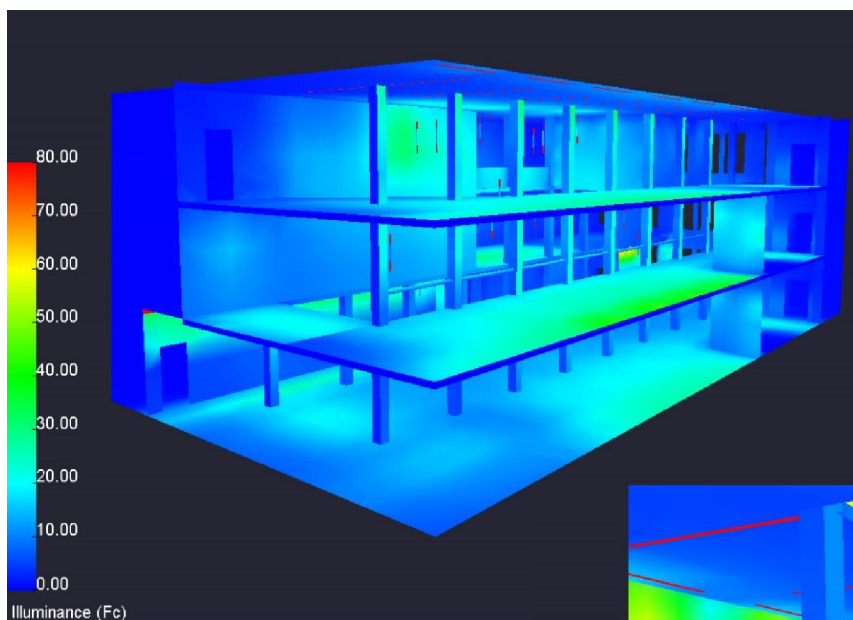

Figure 25

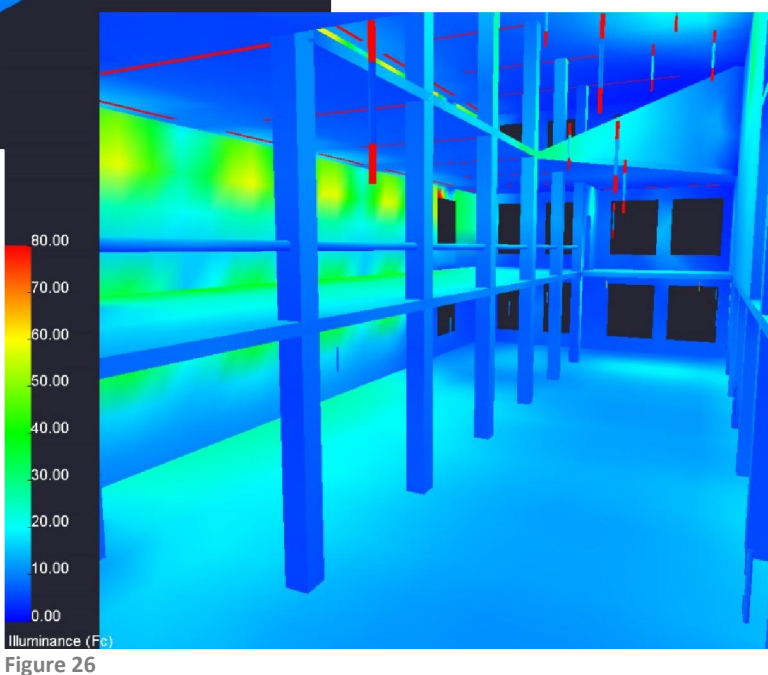

Figure 26



Figure 27

April 9th, 2014



Figure 28



Figure 29

April 9th, 2014

Calculation result from AGI32

Project 1

Calc Pts

1st side

Illuminance (Fc)
Average=17.74 Maximum=30.8 Minimum=5.8 Avg/Min=3.06
Max/Min=5.31

2nd flr big

Illuminance (Fc)
Average=6.84 Maximum=9.3 Minimum=3.6 Avg/Min=1.90
Max/Min=2.58

2nd side_1

Illuminance (Fc)
Average=22.89 Maximum=33.8 Minimum=6.1 Avg/Min=3.75
Max/Min=5.54

3rd side

Illuminance (Fc)
Average=22.55 Maximum=35.0 Minimum=6.2 Avg/Min=3.64
Max/Min=5.65

Atrium

Illuminance (Fc)
Average=12.88 Maximum=24.0 Minimum=5.7 Avg/Min=2.26
Max/Min=4.21

circulation

Illuminance (Fc)
Average=16.70 Maximum=29.8 Minimum=3.1 Avg/Min=5.39
Max/Min=9.61

LPD-UWLR Areas

LPD Open Area

Area(Sq.ft)=4782 Total Watts=4186.578 LPD(Watts/Sq.ft)=0.875

Lighting Plan

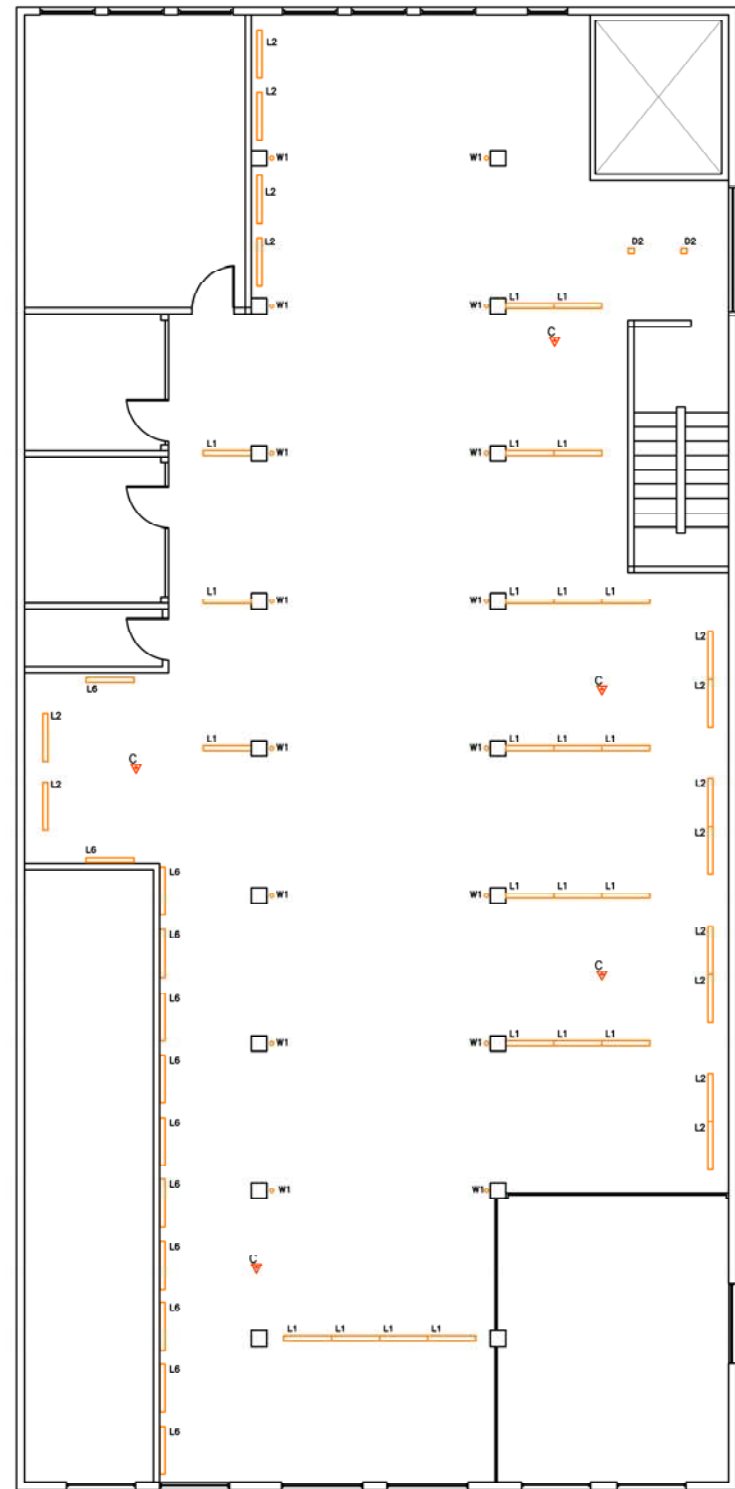
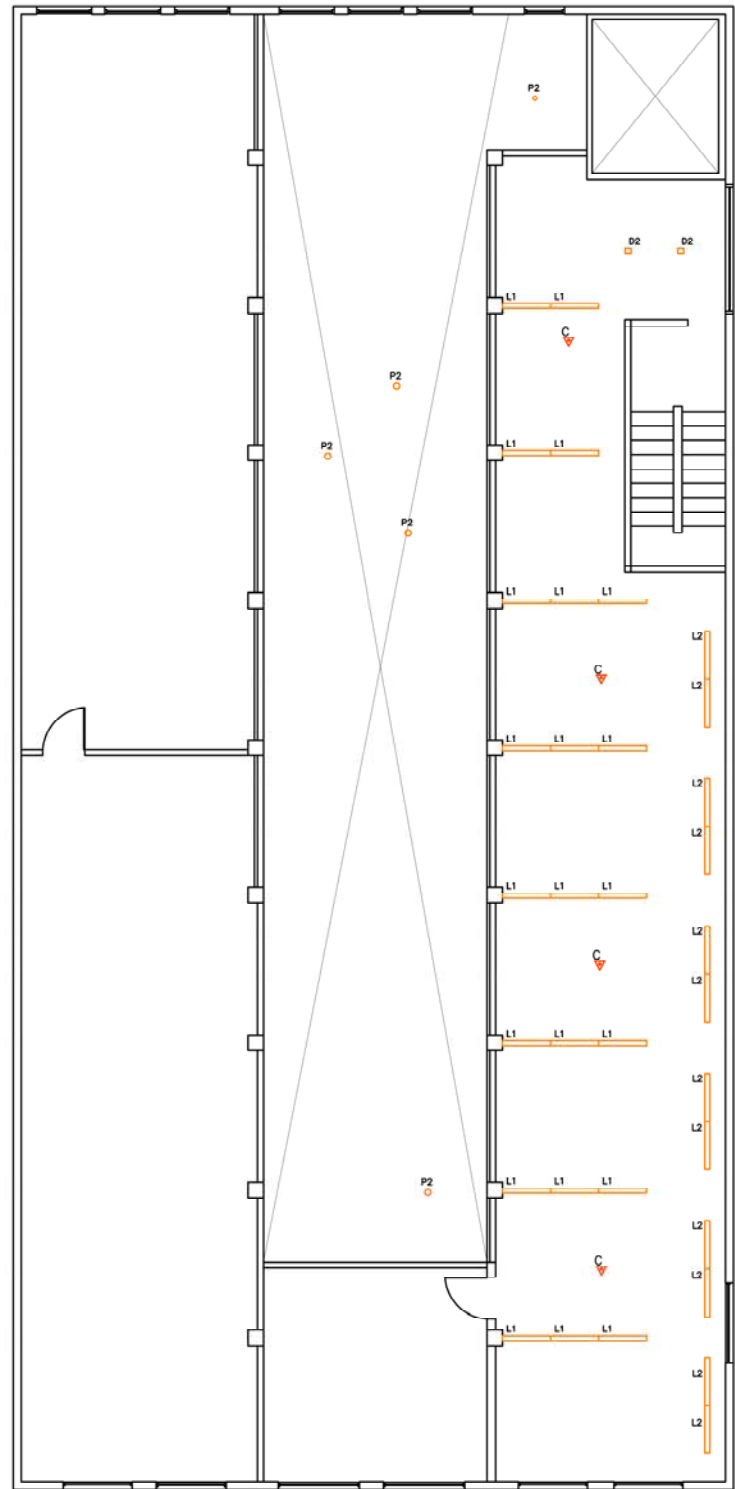
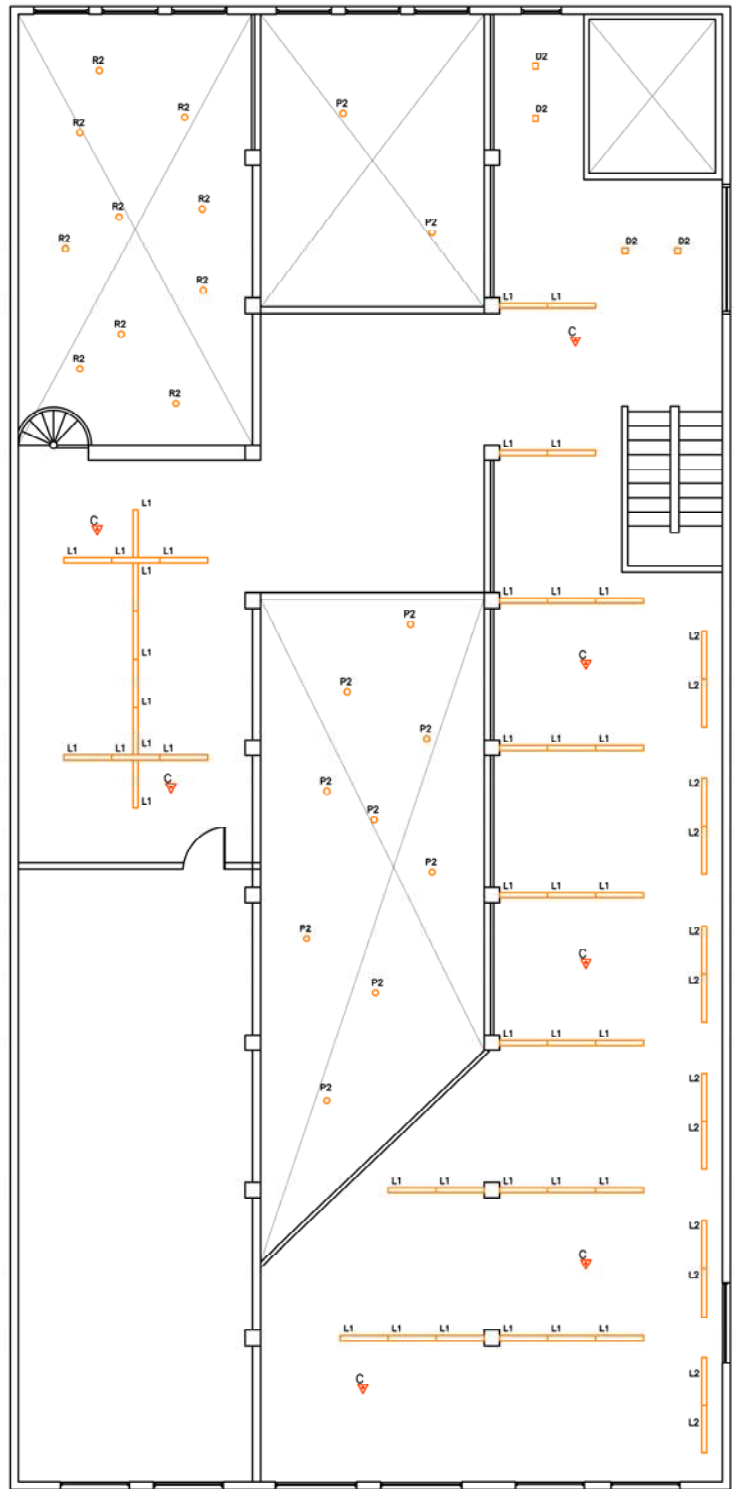

PROJECT:
FRAUNHOFER CSE

CONTENT:
LIGHTING PLAN
LOBBY
CONFERENCE RM

DRAWN BY
XIAOYIN WU

DATE:
APR 2014

SCALE:

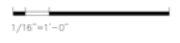

April 9th, 2014

Evaluation

The new architectural interior design provides the office a much open-up space to allow more diversity of lighting design possibilities. The changing of ceiling height in the central bay atrium area generates a lot more vertical space for the options of pendant fixture that original design would not allowed. The vertical tube pendant fixtures are all with different pendant length, also suspended from different levels. This design adds some flavors to the aesthetic aspect of the space and makes the entire space look more dynamic. As it can be seen from the renderings, the side bay areas are mostly either open up to the atrium or can see the atrium through the glazing. Look from different locations in the space, the views with the pendant lights in the opened center space are different. The vertical fixture choice makes sure that the fixtures do not look too dominant in whole the look of the open space. The slim design of the luminaire is like the light beams that go through the tree branches and provide sufficient illuminance for the tasks taking place in the office work space. The recessed continuous linear fixtures are of the same type of the ones in the lobby to remain the consistency of the entire design concept as a whole. The layout is placed along the columns location one is to create a uniform distribution, and also eliminate the glare people may perceive from other area in the open office. The wall washers are installed in all the side bay open working area. The side bay working areas are visually connected to the central atrium and the lit up wall helps define the depth of the space and create the feeling of spaciousness. In general, the opened-up space brings difficulties of reaching uniformity and lighting trespass between the different areas of the space. But the design solution is successfully meet most if not all the goals and the criteria by selecting the right luminaires and layouts adjustment.

April 9th, 2014

FAÇADE



Figure 30

Space Description

The project is a renovation project of a 100-year old historical building of six-story, three-bay loft brick structure with classical revival-style detailing. The Fort Point Channel district is marked by an exceptional degree of visual uniformity. Fraunhofer Building, one of the buildings in the Fort Point Channel area, is not an exception of a loft structure built in 1913 by the Boston Wharf Company, and represent an unusually coherent and well-preserved collection of late 19th and early 20th century lofts that reflect a critical period of social, economic, and physical development in the City and the region. The loft buildings are generally masonry, with simple volumes and flat roofs. Buildings are elegantly proportioned, with classically inspired details concentrated at entrances and cornices. And the structure is left unchanged in this project to conserve the significant continuity throughout the District in terms of massing, scale, and style. In this project, the majority of the structure has been left almost unchanged, especially the façade. Besides the new entrance is more modernized after the renovation, almost the entire of the building façade remain exactly the same as it is about 100 years ago. The façade is mainly made of red bricks with mainly two window types taking up the façade wall.

April 9th, 2014

Dimension

75' x 61' 8" (Height x Width), 6 story, two front entrances

Finishing & Glazing

Table 14

SURFACE	MATERIALS	DESCRIPTION	REFLECTANCE
Ext. Wall	Bricks, masonry window	Salvaged existing red color bricks	0.26

April 9th, 2014

Architectural Drawing



Figure 31

April 9th, 2014

Lighting Design Criteria & Consideration

Façade being an important part of architectural lighting design is usually for the reason that it plays a big role in advertising the architectural features of the building by highlighting the beauty of the structure and/or façade, and also improving the company image. In this project, the hundred-year old building façade was preserved almost entirely. The lighting design should help emphasizing the massing and proportion of the building structure. At the same time, the lighting design shall bear the idea in mind that the company is dedicated in researching energy saving building technology products. So eco-friendly fixtures and design concept should also be a primary consideration.

IES Illuminance Recommendation

Façade with reflection < 0.5 and low activity: $E_v = 40$ lux

ASRAE 90.1 Standard (2010) Requirement

- Building entrances and exits: main entries = 20W/linear-ft of door width
- Façade: 0.1W/sf for each illuminated wall or surface or 2.5 W/linear ft for each illuminated wall or surface length

Lighting Trespass

Light trespass is a critical issue for exterior lighting, because light pollution is now a big problem in the urban area. So the lighting design needs to make sure the aiming and reflection of the light does not trespass to the neighborhood that exceeds the allowance.

Accenting

Accenting is a major way to decorate the exterior of the building that will emphasize the elements of architecture.

Design Goal

The building is a company that does not have activity after around 5pm. Then there is not much need of lighting up the exterior because it is not a commercial building and advertising the

April 9th, 2014

building is not so necessary. So in my design, very subtle lighting that highlights the cornices on the façade would be efficient for a minor decorative purpose of the exterior design goal.

Luminaire Schedule

Table 15

TYPE	#	DESCRIPTION	MANUFACTURER	MODEL	LAMP	WATTS	VOLTS
F1	44	Surface mounted high performance flood lights	RAB	FXLED150SF/PCS	LED	150	120
W1	2	Double sconce direct-indirect wall sconce with white tube diffuser	LIGHTOLIER	PPL5DSW	LED	2.4	120
W2	4	Direct-indirect wall sconce flood light	B-K	OL-LED	LED	75	120

Lighting Plan



Figure 32

April 9th, 2014

Rendering



Figure 33

Evaluation

The design goal is to use the minimum light and reach a low profile façade lighting design. And the design reaches the goal of celebrating the architectural elements, say, the cornices. At the same time it uses the least output to create the visual affect without making any discomfort to the surroundings.

architectural breadth

The point of altering the interior space of the office area is to generating a pleasant working environment for the users and promote a modern looking of the interior space that contrasting the exterior impression the building. With the help of the lighting design concept, the goal of the new architectural design is to create a spacious working space and coordinate perfectly with the new lighting design.

April 9th, 2014

DESIGN CONCEPT

Before digging into the new design concept, the original look of the office can explain the motivation of my desire of redesign the space.



Figure 34



Figure 35

April 9th, 2014

As it can be easily seen from the real pictures, both the space condition before renovation and the current design after the tenant moved in the building. The owner settle with the idea of exposed ceiling structures and mechanical systems and largely use of pendant mounting lighting fixtures with direct and indirect distribution for the ambient light in the work space. Wall sconces are installed for the accenting purpose of the space. Dark color floor carpeting takes a large portion of the floor surface. And the partitions of work station cubicles are blocking the open view of the office area that make the office space even lower and dim. Without the portable table lamps, I doubt the work planes will receive much illuminance as it needed. The building has large windows in a row on every floor on the east and west facades, but the room height and sharp angles are going to prevent enough sunlight getting into the space. The primary daylighting area is so small for the long and narrow office space.

In order to avoid all the downside about the office I'm not completely satisfied with, design concept is decided easily to make the office spacious and bright.

BRIGHTEN YOUR EVERYDAY

Office is the space that people who work there spend most of the daytime in. It is strange in a way, that places that people only stop by for temporarily are well designed, while the place we spend everyday life are designed with the least consideration of appearance. I think office is just as important as the fancy hospitality and retail spaces, and as important as the home design. For example, Google spends large amount of money and effort of build the high end and most considerate campus for its employees and clients. It is a huge investment for building a campus like Google does, but a relatively better quality work environment will sure has some payback from the employees who enjoy working there and have high efficient performance. So I want the office to be able to brighten everyday life of the users and users in return brighten the company the same way.

April 9th, 2014

DESIGN APPROACH

“OPEN” & “TRANSPARENT” are the two key words of my design ideas. To get rid of the gloomy and suppressed feeling of the office space and to provide the users pleasant feeling, a new lighting design for the space solely is not enough for this goal. So I want to bring in more opportunity to the space for a better working environment. Considering the 4th and 5th floors are still vacant and to be designed for more office spaces, it is not hard to come up with the idea that the 3rd floor office can be opened up to the upper levels and redo the layout to make the space more dimensional.

I want the tenant in the building perceive a much broadened view without much clutter as well. The completely opened space has an issue of the sound transmit throughout the entire space that doesn't have partition separate the different areas. So glazing is largely used in the space. The finishing of the interior surfaces is mainly white colored theme. It will help the space look modern and spacious visually and will help the light bounces around. The ceiling will have panel finish so to get rid of the expose beam structure and the HVAC system hanging above the work area. The space will look much cleaner and contemporary.

The following pictures are some major inspiration and the look that I was going for for the office space in the beginning. It is a way for me to be sure about the design concept I have is not just an idea on the drawing, but also some real life projects are done the similar way as well.

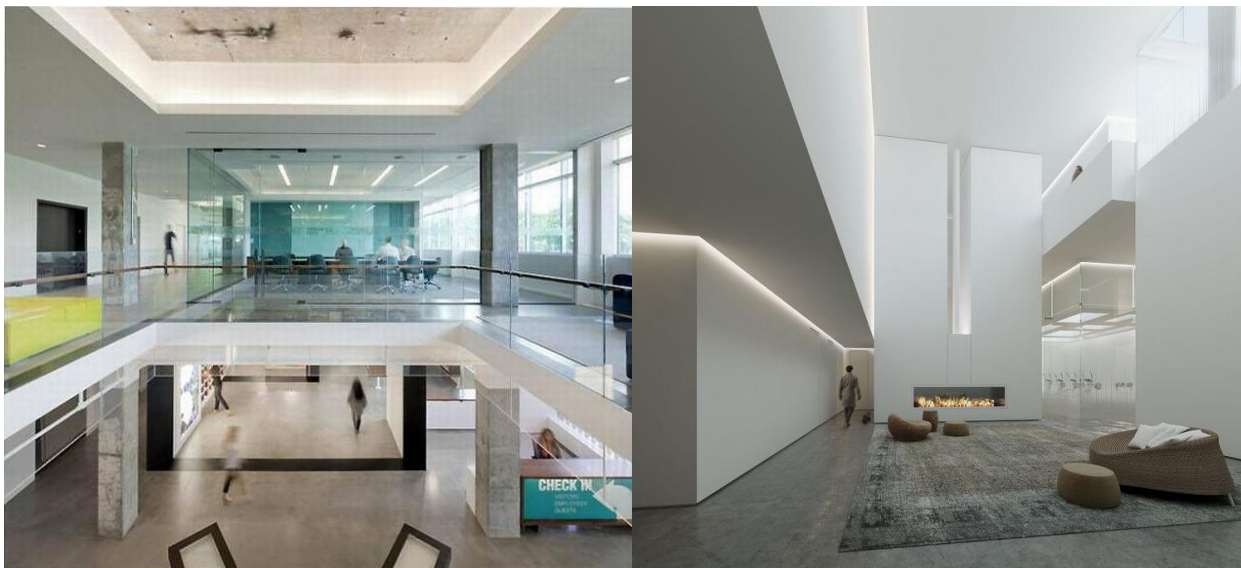

Figure 36

April 9th, 2014

The section below shows the part I will modify in the building. Most of the floor and ceiling between the 3rd and 4th, 4th and 5th levels are removed to have the open atrium. Part of the center bay will remain as for the diversity of floor plan layout as well as make it easier to circulate around the building.

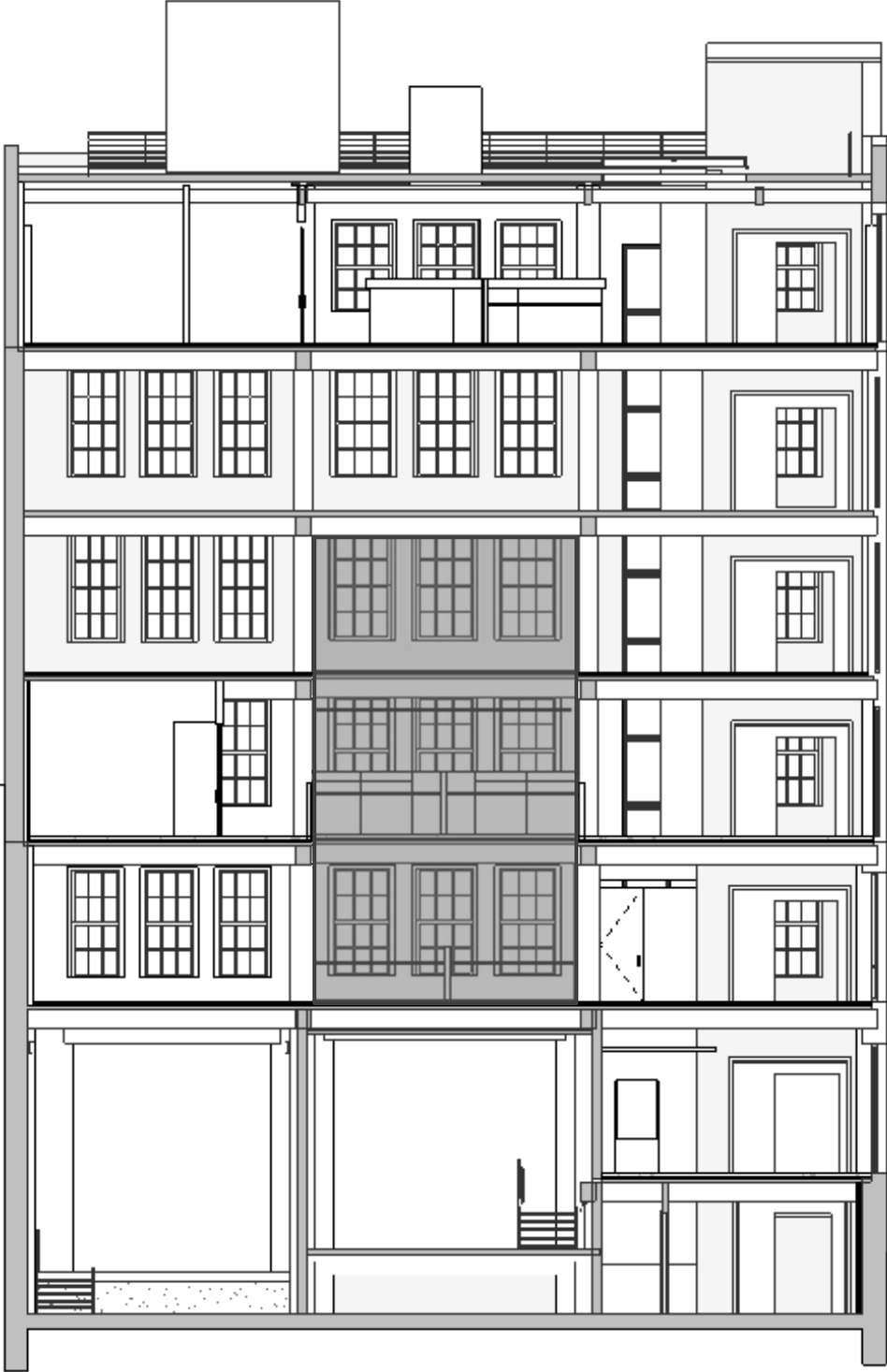

Figure 37

April 9th, 2014

EXISTING FLOOR PLAN

Please Refer to the Appendix C for Floor Plan.

FLOOR PLAN



The north corner of the building remains almost unchanged because that's the main stair case and some electrical shaft and mechanical room and bathroom. So I leave that space as it is all the way through the three levels. And the stairs and the elevator shaft at the south corner also stay the same. There are different sizes of private offices on the 3rd floor just as in the previous design where enclosed offices are located on the side bays of the building. In the north corner on the two upper levels, more private offices will be place in there too. But that will be out of my design scope, and I will not have the detailed design solution for that space.

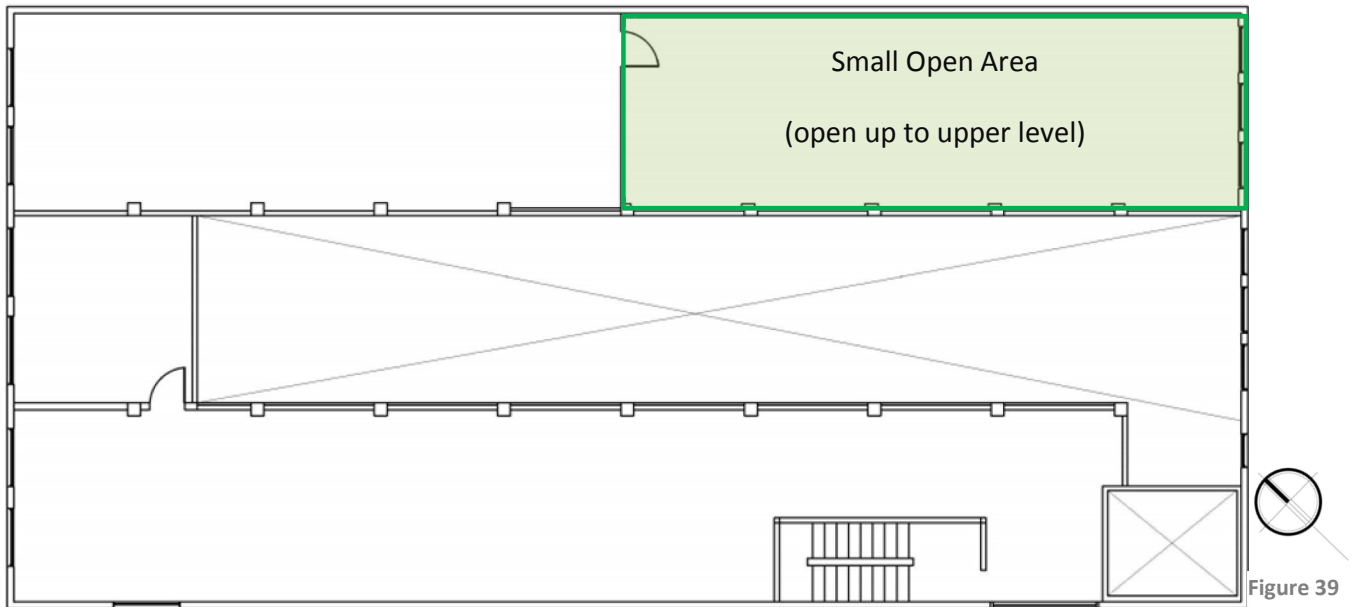

Figure 39

The big space on the east corner of the plan is another high ceiling space within the new open office area. That area is a small open office in size and has two story-tall ceiling. It is connect to the upper level platform on the 5th floor level. That enclosed space solely is another form of the loft structure that also represents the idea of diverse geometry of the open office design.

On the most upper level (5th floor level), the west corner bridge connect the north and south bay of the building and not shaped regularly along the beam direction. However it creates more floor area and a more convenience circulation purposes.

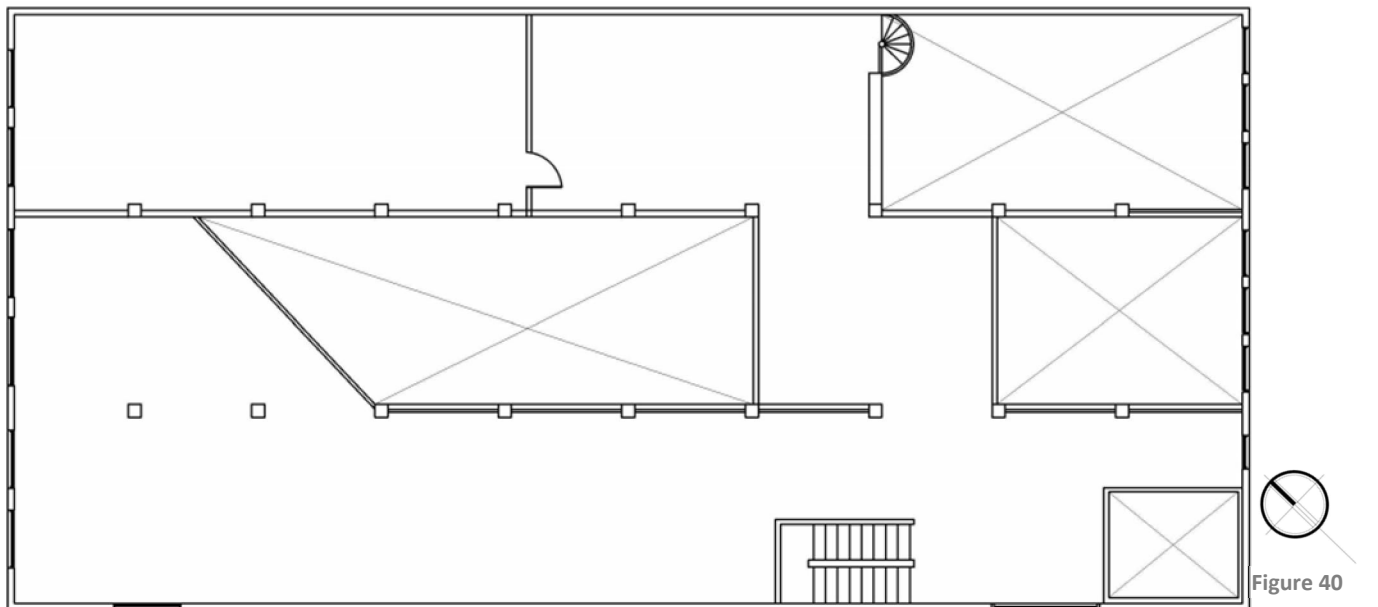

Figure 40

April 9th, 2014

RENDERING



Figure 41



Figure 42

structural breadth

Structural breadth is conducted to support the significant architectural change in the office space. This breadth includes the analysis of the feasibility of the changing being made in the interior building structure and calculations to make sure if resizing the structure element is necessary.

April 9th, 2014

OVERVIEW

By removing the floor in part of the center bay of the structure, the deadload decreases on the column. In the depth,

EXISTING STRUCTURE



Figure 43

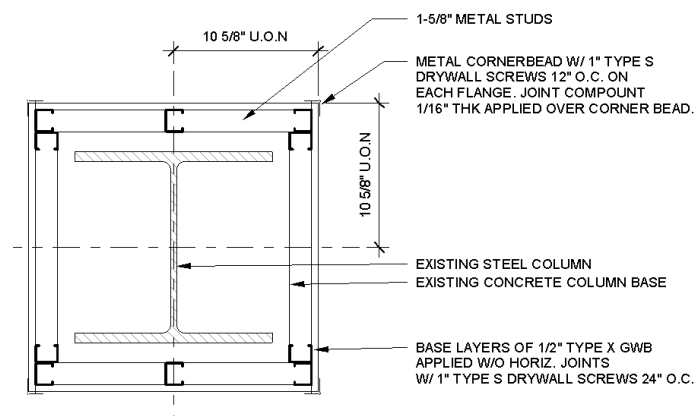

Figure 44

April 9th, 2014

Table 16

	Type	Load
Level 4 floor	dead load	80 PSF
Level 5 floor	dead load	80 PSF
People	liveload	60 PSF

CALCULATION

The reduced deadload of floor from the 4th floor is:

Total removed floor area = 1786SF

Total deadload = 142,990 LB = 143 kip

Tributary are for columns in the center: 122.5SF

Tributary area for columns on the end: 183.7SF

Existing Beams:

Timber beams 8.5 x 16

In this case, there will be less beam-bearing load. And the center bay beams that span over 20' will be removed. So the columns will be bearing the load on the side bays.

The only place that will need new beams is the 5th floor level triangle shape. Longer beam will need to be place to bridge from one end diagonally to the other side.

By using a W10x39 beam

Mu (Demand)	74.08 kip-ft
Φ Mn (Capacity)	126.36 kip-ft
Controlling Equation	F2.1: Yielding
Location	10' 5"
Load Combo	1.4D

Bending=0.59

April 9th, 2014

Vu (Demand)	-12.29 kip
ΦV_n (Capacity)	67.50 kip
Controlling Equation	G2.1: Nominal Shear Strength
Location	18' 3"
Load Combo	1.4D
Shear = 0.18	

Based On	Service Cases
Max Service Case	Wind Limit
Max Dy	-0.678 in = L/370
Live Load Limit	L/360
Dead + Live Limit	L/360
Snow or Wind Limit	L/360
Total Load Limit	L/240
Deflection=0.97	

electrical design

With the lighting design largely altered in several spaces in the building, the panelboards that feed the lighting circuits will need to be updated. And with the changing lighting load, a short circuit study also need to be studied to make sure whether the protection system is sufficient enough to support the new electrical system according to the new lighting design. Then a depth on integrating the photovoltaic arrays in the power system will be discussed to see how the PV arrays can be utilized in the electrical system to provide sustainable energy supply.

April 9th, 2014

INTRODUCTION

After the changing of design in the four spaces in the building, the panelboards needs to be redesigned to keep up with the current design. The levels that have the lighting systems remain unchanged can be left as it is on the related panelboards. Otherwise, the affected panelboards will be updated and some spare circuits on the panelboard that currently not serving any load will be used as well to accommodate the new lighting system. Automatic control systems are installed according to the ASHRAE 90.1 standard. In the open office space, not only occupancy sensors, but also photosensors will be applied. Because the architecture is largely altered in the office space in order to provide more daylight entrance in the space, so the lighting should be controlled based on the changing of daylighting during the day, in order to minimize the energy usage in the electrical system.

CONTROL SYSTEM

In the new design, more automatic control system and dimming equipment are designed be used in the building.

The goal of the control system is to turn off/or dim the lights when there are no occupant in the area or when the daylight is available so to save energy. In general, the automatic shut off system will be used in the entire building according to the requirement in the ASHRAE 90.1 standard that interior lighting in building shall be controlled with an automatic control device to shut off building lighting in all spaces. For conference room especially, occupant sensor is required that turns off lights within 30min of occupants leaving the space. At the same time, the automatic control devices in all the interior spaces shall be manual on or auto on to 50%. The conference room and lobby do not need automatic daylighting control devices because the combined primary sidelighted area in spaces do not exceed 250 SF not there are any skylights. The open office atrium needs the automatic daylighting control.

Control Devices

April 9th, 2014

The conference room control system are using the *WattStopper*®'s occupancy sensors and control panel to meet to requirement of having automatic shut-off control system. No other automatic control system is needed because it's a multi-scene space.

The open office uses area vacancy sensor on the two side bays and photo sensors for the central bay atrium area.

The drawings below show the operation diagram. The first one shows the ceiling occupancy sensor controlling single light source. And the second one is for ceiling occupancy sensor controlling multiple lighting sources. The occupancy sensor enables automatic control of room lighting upon occupant detection. Sensors do not turn on lighting solely upon occupant detection. Sensors shall turn off all room lighting upon room vacancy after adjustable time as long as it's within 30 minutes.

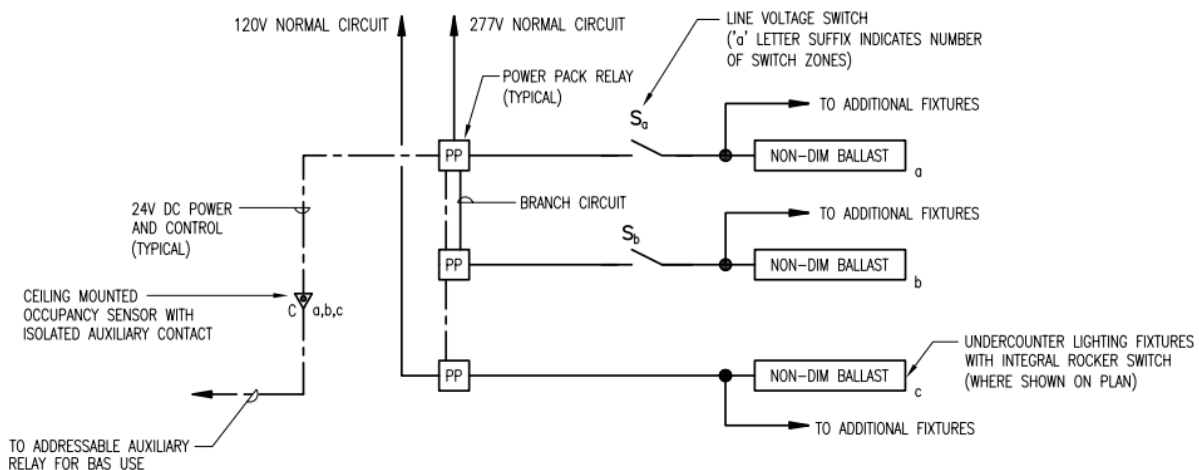
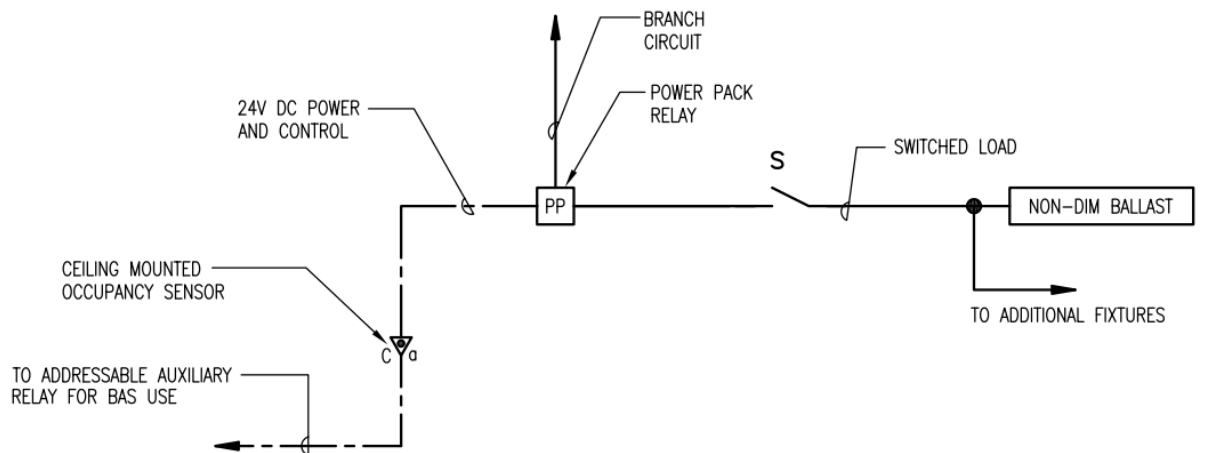

The control devices cutsheets can be found in the appendix A.

April 9th, 2014

PANELBOARDS and BRANCH CIRCUIT REDESIGN

The lobby and conference room are located on the first floor. So the panelboards will be updated with the new loads that I calculate with the new lighting fixture information. The take-up of the new load is a simple process by summing up the existing lighting load and replaced by the new total load in the space. So on the panel board, the relating circuit will be replaced by new circuits that serving the new load.

The third floor office space is altered significantly and the whole lighting system on the affected space, fourth and fifth floors, will be considered as a whole and current panelboards on not only the 3rd floor but also 4th and 5th floors. And spare circuit will most likely to be used for adding in finished lighting design on the 4th and the 5th floor because there are no current finished lighting system on the two floor.

After removing the existing lighting load and assign the new loads to the circuit evenly, adding more new circuits as needed and then resize the feeders, wires and conduits by following the requirements on NEC.

The panelboards that will be affected by the new design in the four areas I designed in the building is listed in the table below. And the distribution panels that feeds the panels are DP21A and DP21B that located in the basement and the on the 4th floor.

Table 17

Panel Tag	Voltage	Lobby	Conference	Office	Façade
P21B	120/208V	X	X		
P23	120/208V			X(LVL3)	
L42	277/480V			X(LVL3)	
L44	277/480V			X(LVL5)	X(LVL6)
EP4B	277/480V	X		X	X
EP2B	120/208V	X		X	

First, I want to explain how the electrical load take-out. The panelboard schedule shown below is the original panel board schedule. The circuits that highlighted in red are the circuits that will be changed after the new design. The circuits to be replaced with the new loads basically follow the same idea of how the loads are distributed in the original design. Circuit that wires a certain

April 9th, 2014

area is still designated to the same area also with the consideration of how to change the total load in each line. This way, it will avoid resizing the wire, conduit and bus. But over current protection will be discussed later to make sure the current protection system is up to date and are efficient to support the new load, since the new load will be larger than before on Level 1.

P21B	120/208V	3 PHASE			4 WIRE			TOTAL WATTS L1: 9650			TOTAL WATTS: 31998		
	MAIN BREAKER: MLO											LOCATION	
	MAIN BUS: 225A											LEVEL 1 ELEC. RM	
LOAD	DIRECTORY	L1	L2	L3	CKT	AMPS	AMPS	CKT	L1	L2	L3	DIRECTORY	LOAD
R	RECEPTION REC	800			1	20	20	2	864			DISPOSER 1/2HP	E
R	FIRE COMMAND REC		600		3	20	20	4		360		RECEP. ST-11	R
R	LOBBY RECEP			720	5	20	20	6			540	GFCI	R
R	LOBBY REC	1000			7	20	20	8	720			RECEP. F113	R
R	LARGE CONF.		800		9	20	20	10		800		SP1 PANEL RM F103	E
R	LARGE CONF. PART			1000	11	20	20	12			1176	FCU-3	E
R	LARGE CONF.	800			13	20	20	14	864			FCU-4	E
R	TV REC		600		15	20	20	16		2400		FCU-4	E
R	OFFICE			1000	17	20	20	18			2400	FPB-2	E
R	CORRIDOR	800			19	20	20	20	200			SP1 PANEL RM F103	R
R	LOAD CHECK		400		21	20	20	22		800		VP AND MS	E
R	ELEV EM			400	23	20	20	24			1524	LEVEL1 VIA LVRP-1-3,5	L
E	DOOR POWER SUPPLY	800			25	20	20	26	1684			LEVEL 1 LVRP-1-6	L
E	FCU-10				27	20	20	28		1226		LEVEL 1 LVRP-1-7	L
E	FDCG-70			2400	29	20	20	30			1250	LOBBY LTG	L
E	QUAD F11	360			31	20	20	32	758			LEVEL 1 LVRP-1-11	L
E	RECEP F104		180		33	20	20	34		500		RECEP F114&FCU-34	R
L	LEVEL1 VIA LVRP-1-2			912	35	20	20	36			360	RECEP. F114	R
S	SPARE				37	20	20	38				SPARE	S
S	SPARE				39	20	20	40				SPARE	S
S	SPARE				41	20	20	42				SPARE	S
	SUBTOTAL	4560	2580	6432					5090	6086	7250		

The affected lighting loads are summarized in table-#. The lights are being taken out of the current design are summed up by circuit. The new assignment of the new lighting system onto the panel board P21B is shown in table-#. When assigning new load to the circuit, I tried not to exceed the original load in order to avoid the possibility of resizing of wire or feeder.

April 9th, 2014

Table 18

CKT #	Type	#	Watt	Total watt	Total on circuit
7	L17	7	12.5	87.5	87.5
24	W10	10	4.8	48	
	R11	3	39	117	
	L20	6	13	78	
	L20A	4	6	24	
	L15B	1	32	32	386.5
26	R10	1	39	39	
	R11	7	39	273	
	L20A	4	6	24	
	L20	2	13	26	
	L21	1	38	38	400
28	L20	4	13	52	
	P1	3	10	30	
	L21	2	38	76	158
30	L20A	6	6	36	
	L19	4	10	40	
	T3	3	16	48	124
32	R13	18	11	198	198
35	L21	3	38	114	114

Table 19

Type	Description	#	Watt	Total Watts	Location	Assgn. Ckt
L1	Linear	27	19.2	518.4	lobby	28
L2	Wallwasher	2	35	70	conf	35
D2	Downlight	16	18.6	297.6	lobby	24
L3	Cove	32	25.1	803.2	conf	38
L4	Wall recessed	16	18.55	296.8	lobby	26
P2	Pendant	6	9.9	59.4	conf	32
R1	Downlight	14	8	112	conf	32
P1	Pendant above desk	1	48.6	48.6	lobby	30
L5	Logo wall	4	5.9	23.6	lobby	30

The following table is the new panelboard schedule for panelboard P12B. The cells that are highlighted in yellow are the altered circuit with new load based on the table above. The total load is slightly higher than the original design. Although I think it is not a problem because more lighting

April 9th, 2014

fixtures with decorative purposed are installed in the lobby area. But as discussed in the lighting depth, most of the lighting loads are contributed by the fixtures in the large conference room, and

P21B	120/208V	3 PHASE			4 WIRE			TOTAL WATTS L1: 10275			TOTAL WATTS: 32878		
	MAIN BREAKER: MLO							TOTAL WATTS L2: 9026			LOCATION		
	MAIN BUS: 225A							TOTAL WATTS L3: 13577			LEVEL 1 ELEC. RM		
LOAD	DIRECTORY	L1	L2	L3	CKT	AMPS	AMPS	CKT	L1	L2	L3	DIRECTORY	LOAD
R	RECEPTION REC	800			1	20	20	2	864			DISPOSER 1/2HP	E
R	FIRE COMMAND REC		600		3	20	20	4		360		RECEP. ST-11	R
R	LOBBY RECEP			720	5	20	20	6			540	GFCI	R
R	LOBBY REC	913			7	20	20	8	720			RECEP. F113	R
R	LARGE CONF.		800		9	20	20	10		800		SP1 PANEL RM F103	E
R	LARGE CONF. PART			1000	11	20	20	12			1176	FCU-3	E
R	LARGE CONF.	800			13	20	20	14	864			FCU-4	E
R	TV REC		600		15	20	20	16		2400		FCU-4	E
R	OFFICE			1000	17	20	20	18			2400	FPB-2	E
R	CORRIDOR	800			19	20	20	20	200			SP1 PANEL RM F103	R
R	LOAD CHECK		400		21	20	20	22		800		VP AND MS	E
R	ELEV EM			400	23	20	20	24			1515	LEVEL1 VIA LVRP-1-3,5	L
E	DOOR POWER SUPPLY	800			25	20	20	26	1619			LEVEL 1 LVRP-1-6	L
E	FCU-10				27	20	20	28		1586		LEVEL 1 LVRP-1-7	L
E	FDCG-70			2400	29	20	20	30			1198	LOBBY LTG	L
E	QUAD F11	360			31	20	20	32	732			LEVEL 1 LVRP-1-11	L
E	RECEP F104		180		33	20	20	34		500		RECEP F114&FCU-34	R
L	LEVEL1 VIA LVRP-1-2			868	35	20	20	36			360	RECEP. F114	R
S	SPARE				37	20	20	38	803			LEVEL 1 LOBBY	L
S	SPARE				39	20	20	40				SPARE	S
S	SPARE				41	20	20	42				SPARE	S
	SUBTOTAL	4473	2580	6388					5802	6446	7189		

the power density in the lobby area is actually much lower than the current design.

With the same method, other panel boards are updated in the similar fashion. Here are the new panel board schedules. The original schedules can be found in the appendix pages. Also, the affected circuits are in red for convenience of comparing with the new schedules.

April 9th, 2014

L42	277/480V		3 PHASE	4 WIRE	TOTAL WATTS L1: 6060						TOTAL WATTS: 20920			
	MAIN BREAKER: MLO				TOTAL WATTS L2: 6008						LOCATION			
	MAIN BUS: 100A				TOTAL WATTS L3: 8852						LEVEL 2 ELEC. RM			
LOAD	DIRECTORY	L1	L2	L3	CKT	AMPS	AMPS	CKT	L1	L2	L3	DIRECTORY	LOAD	
L	BASEMENT	1100			1	20	20	2				STAIR 2	L	
L	STAIR 1				3	20	20	4		800		LVL 2, CORE	L	
L	LVL.1 CORE			1200	5	20	20	6			2301	LVL 3, CORE	L	
L	LVL.1 ELEX&LD DOCK	1480			7	20	20	8	1091			BASEMENT	L	
L	LEVEL 1		900		9	20	20	10		700		BASEMENT	L	
L	LEVEL 2			512	11	20	20	12			1380	PV HIGH BAY	L	
L	SPARE				13	20	20	14				SPARE	L	
L	SPARE				15	20	20	16		768		LEVEL 1 LTG	L	
L	SPARE				17	20	20	18			1408	LEVEL 2	L	
L	LEVEL 2 LVPR-1-15	203			19	20	20	20	1104			LVL2 LVPR-1-13,14,15	L	
S	SPARE				21	20	20	22		2300		LEVEL 3	L	
L	LEVEL 3			882	23	20	20	24			969	LEVEL 3 LVPR-1-20,21	L	
L	LIGHTING	882			25	20	20	26						
L	LIGHTING CONTROL		200		27	20	20	28						
L	LIGHTING CONTROL			200	29	20	20	30						
L	LIGHTING CONTROL	200			31	20	20	32						
L	LIGHTING		340		33	20	20	34						
					35	20	20	36						
					37	20	20	38						
					39	20	20	40						
					41	20	20	42						
	SUBTOTAL	3865	1440	2794					2195	4568	6058			
EP2B	120/208V		3 PHASE	4 WIRE	TOTAL WATTS L1: 3664						TOTAL WATTS: 20920			
	MAIN BREAKER: MLO				TOTAL WATTS L2: 3778						LOCATION			
	MAIN BUS: 100A				TOTAL WATTS L3: 1702						LEVEL 2 ELEC. RM			
LOAD	DIRECTORY	L1	L2	L3	CKT	AMPS	AMPS	CKT	L1	L2	L3	DIRECTORY	LOAD	
E	FOP-1, LEVL1 (1/4HP)	1400			1	20	20	2	500			ELEV CAB LTG	E	
E	FOP-2, LEVL1 (1/4HP)		1400		3	20	20	4		500		ELEV CAB PWR	E	
E	LVL 1 FACP				5	20	20	6			500	ELEV REM. MONTR	E	
E	LVL 1 FACP				7	20	20	8	500			GEN. PWR	E	
E	LVL 4 FACP				9	20	20	10		500		GEN. LTG	E	
E	LVL 4 FACP				11	20	20	12			200	EMRG ELEC RM REC	R	
E	LVL 6 BDA				13	20	20	14	200			FIRE PUMP REC	R	
E	LVL 6 BDA				15	20	20	16		550		ELEV PIT & CNTRL RM	R	
E	SBSMNT. SMOKE DAMP				17	20	20	18			550	TOP ELEV SHAFT	R	
E	LVL 1 SMOKE DAMP				19	20	20	20	200			BSMNT HEAT TRACE	E	
E	LVL 2 SMOKE DAMP				21	20	20	22		78		LIGHTING VESTIBULE	L	
E	LVL 3 SMOKE DAMP				23	20	20	24			75	LVL 1 LIGHTING	L	
E	LVL 4 SMOKE DAMP				25	20	20	26	864			FIRE SHUTTER	E	
E	LVL 5 SMOKE DAMP				27	20	20	28		200		FIRE SHUTTER CTRL	E	
E	LVL 6 SMOKE DAMP				29	20	20	30			377	LVL 2 LIGHTING	L	
E	SPARE				31	20	20	32				SPARE	S	
L	LVL 6 LIGHTING		390		33	20	20	34		160		LVL 3 LIGHTING	L	
S	SPARE				35	20	20	36				SPARE	S	
S	SPARE				37	20	20	38				SPARE	S	
S	SPARE				39	20	20	40				SPARE	S	
S	SPARE				41	20	20	42				SPARE	S	
	SUBTOTAL	1400	1790	0					2264	1988	1702			

April 9th, 2014

EP2B	120/208V		3 PHASE	4 WIRE	TOTAL WATTS L1: 892			TOTAL WATTS: 6179					
	MAIN BREAKER: MLO				TOTAL WATTS L2: 2800			LOCATION					
	MAIN BUS: 100A				TOTAL WATTS L3: 2487			BSMNT EMRG. ELEC RM					
LOAD	DIRECTORY	L1	L2	L3	CKT	AMPS	AMPS	CKT	L1	L2	L3	DIRECTORY	LOAD
S	SPARE				1	20	20	2	400			ELEC. ROM. CORR.	R
E	FCU-20		2400		3	20	20	4		400		VESTIBULE REC	R
L	LVL 4,5 LIGHTING			1647	5	20	20	6			840	LVL 4,5 LIGHTING	L
L	LVL 4,5 LIGHTING	184			7	20	20	8	308			LVL 4,5 LIGHTING	L
S	SPARE				9	20	20	10				SPARE	S
S	SPARE				11	20	20	12				SPARE	S
S	SPARE				13	20	20	14				SPARE	S
S	SPARE				15	20	20	16				SPARE	S
S	SPARE				17	20	20	18				SPARE	S
S	SPARE				19	20	20	20				SPARE	S
S	SPARE				21	20	20	22				SPARE	S
S	SPARE				23	20	20	24				SPARE	S
S	SPARE				25	20	20	26				SPARE	S
S	SPARE				27	20	20	28				SPARE	S
S	SPARE				29	20	20	30				SPARE	S
S	SPARE				31	20	20	32				SPARE	S
S	SPARE				33	20	20	34				SPARE	S
S	SPARE				35	20	20	36				SPARE	S
S	SPARE				37	20	20	38				SPARE	S
S	SPARE				39	20	20	40				SPARE	S
S	SPARE				41	20	20	42				SPARE	S
	SUBTOTAL	184	2400	1647					708	400	840		

As can be seen from all the panel boards that have been changed, the total wattage exceeds the original design. However, the fourth and fifth floor does not have designed so there aren't lighting systems installed. In this condition, the exceeding part of the wattage is actually a very small portion and it will be more energy efficient compares to the two the floors if there is fully installed lighting system.

SHORT CIRCUIT ANALYSIS

Short circuit analysis is conducted for the Fraunhofer CSE building electrical system to ensure the equipment can support the new load or needs to be replaced.

SWITCHBOARD "SWBD-1" SCHEDULE												
HORZ. BUS: 1600A			VERT. BUS: 1600A			S.C.R.: *			NEUT. BUS: 1600A			
GROUND BUS: FULL			NEMA CLASS: *			VOLTAGE: 480/277V, 3 ϕ , 4W			ENCL. NEMA TYPE: *			
COMPT. NO.	EQUIPMENT DESIGNATION	DISCONNECT DEVICE				FEEDER						REMARKS
		POLES	FRAME	TRIP	TYPE	WIRE		GROUND		CONDUIT		
						NO.	SIZE	NO.	SIZE	NO.	SIZE	
1	INCOMING LINE											
2	UTILITY METERING											
3	MAIN CIRCUIT BREAKER	3	1600	1600	-							
4	CH-1 (200 TONS)	3	400	350	-	3	#250	1	#4	1	2-1/2"	1
5	DISTRIBUTION PANEL 'DP41A'	3	400	400	-							
6	DISTRIBUTION PANEL 'DP41B'	3	400	400	-							
7	'DP21A' VIA XFMR	3	400	300	-							
8	'DP21B' VIA XFMR	3	400	300	-							
9	DISTRIBUTION PANEL 'DP4P'	3	400	400	-							
10	ATS-700	3	400	400	-							
11	PENTHOUSE PANEL "DP2P"	3	400	300	-							
12	SPARE	3	400	350	-							
13	SPARE											
14	SPARE											

The calculation starts from the main circuit breaker and a series of following distribution system to the panelboards on different locations in the building. If the current does not exceed the existing feeder capacity, there is no need to replace the equipment, however if the current is over the capacity, that means the over current may occur and the equipment needs to be updated to support the new load.

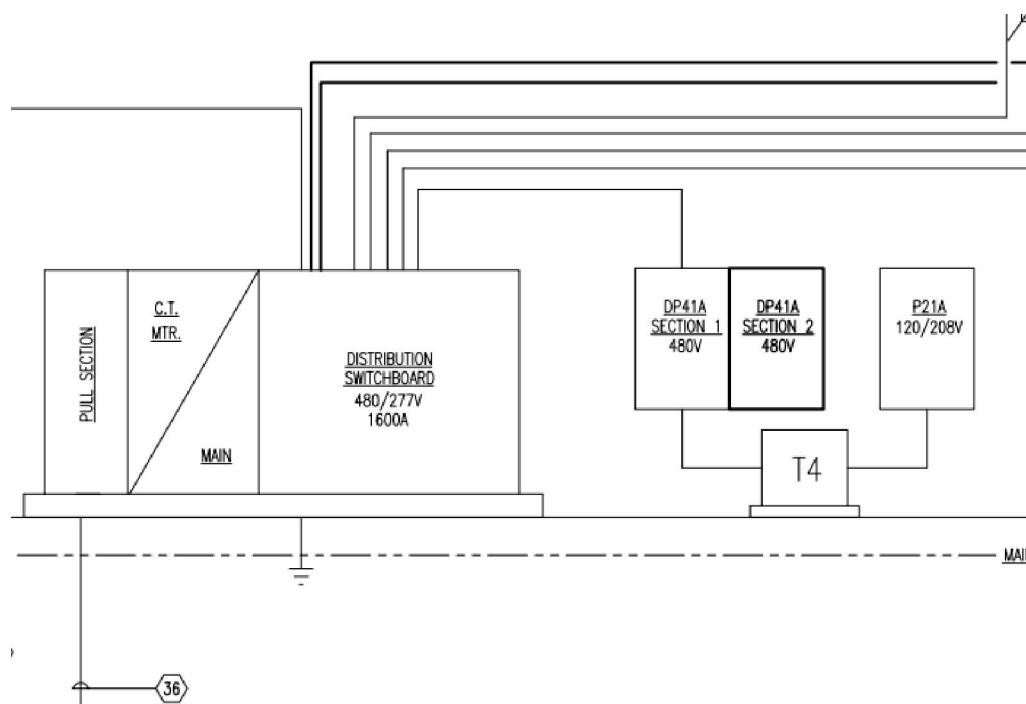

April 9th, 2014

FLA=1600A

$$\text{Multiplier} = \frac{100}{3.5} = 28.57$$

$$I_{sc} = 1600 \times 28.57 = 42,855A$$

$$I_{sc, \text{moter}} = 4 \times 1600 = 6400A$$

$$I_{\text{total}} = 42,855 + 6400 = 49,255A$$

$$f = \frac{1.732 \times 30.8 \times 42855}{16483 \times 3 \times 480} = 0.0963$$

$$M = \frac{1}{1+0.0963} = 0.912$$

$$I_{sc \text{ sysrms}} = 42,855 \times 0.912 = 39,091A$$

$$I_{sc \text{ moter}} = 4 \times 1600 = 6400A$$

$$I_{\text{total}} = 39091 + 6400 = 37,491A$$

With the same method and the distribution riser diagram and the according conductor size in the legend below.

$$f = \frac{1.732 \times 112.4 \times 39091}{22965 \times 4 \times 480} = 0.1726$$

$$M = \frac{1}{1+0.1726} = 0.8528$$

$$I_{sc \text{ sysrms}} = 39091 \times 0.8528 = 33,337A$$

$$I_{sc \text{ moter}} = 4 \times 1600 = 6400A$$

$$I_{\text{total}} = 33,337 + 6400 = 39737A$$

April 9th, 2014

LEGEND OF FEEDER SIZES					
COPPER CONDUCTORS - XHHW/XHHW-2					
FEEDER SYMBOL	CONDUCTORS (3 PHASE, 3 WIRE WITH GROUND)	RACEWAY SIZE CONDUIT	CONDUCTORS (3 PHASE, 4 WIRE WITH GROUND)	RACEWAY SIZE CONDUIT	NOMINAL AMPERE RATING
①	3#4 & 1#10G.	1"			60
②			4#4 & 1#10G.	1 1/4"	
③	3#4 & 1#8G.	1"			70
④			4#4 & 1#8G.	1 1/4"	
⑤	3#1 & 1#8G.	1 1/2"			100
⑥			4#1 & 1#8G.	1 1/2"	
⑦	3#1/0 & 1#6G.	1 1/2"			125
⑧			4#1/0 & 1#6G.	2"	
⑨	3#1/0 & 1#6G.	2"			150
⑩			4#1/0 & 1#6G.	2"	
⑪	3#2/0 & 1#6G.	2"			175
⑫			4#2/0 & 1#6G.	2"	
⑬	3#3/0 & 1#6G.	2"			200
⑭			4#3/0 & 1#6G.	2 1/2"	
⑮	3#4/0 & 1#4G.	2 1/2"			225
⑯			4#4/0 & 1#4G.	2 1/2"	
⑰	3#250 KCMIL & 1#4G.	2 1/2"			250
⑱			4#250 KCMIL & 1#4G.	2 1/2"	
⑲	3#350 KCMIL & 1#4G.	3"			300
⑳			4#350 KCMIL & 1#4G.	3"	
㉑	3#500 KCMIL & 1#3G.	3"			350
㉒			4#500 KCMIL & 1#3G.	3 1/2"	
㉓	3#600 KCMIL & 1#3G.	3 1/2"			400
㉔			4#600 KCMIL & 1#3G.	4"	
㉕	6#250 KCMIL & 2#2G.	2-2 1/2"			500
㉖			8#250 KCMIL & 2#2G.	2-3"	
㉗	6#350 KCMIL & 2#1G.	2-3"			600
㉘			8#350 KCMIL & 2#1G.	2-3"	
㉙	6#600 KCMIL & 2#1/0G.	2-3 1/2"			800
㉚			8#600 KCMIL & 2#1/0G.	2-4"	
㉛	9#400 KCMIL & 3#2/0G.	3-3"			1000
㉜			12#400 KCMIL & 3#2/0G.	3-3 1/2"	
㉝	9#600 KCMIL & 3#3/0G.	3-3 1/2"			1200
㉞			12#600 KCMIL & 3#3/0G.	3-4"	
㉟	12#600 KCMIL & 4#4/0G.	4-3 1/2"			1600
㊱			16#600 KCMIL & 4#4/0G.	4-4"	
㊲	15#600 KCMIL & 5#250 KCMIL G.	5-4"			2000
㊳			20#600 KCMIL & 5#250 KCMIL G.	5-4"	

DISTRIBUTION PANEL "DP4P" SECTION 1 SCHEDULE							PENTHOUSE
277/480 VOLTS		3 PHASE		4 WIRE		* AIC	
MAIN BUS SIZE: 400 AMPS		NEUTRAL: 100%		GROUND BUS: FULL			
MAIN DEVICE: MLO		MOUNTING: SURFACE					
CIRCUIT NUMBER	LOAD ITEM	OVERCURRENT DEVICE			FEEDER SIZE	REMARKS	
		FRAME	TRIP	POLE			
1	PANEL 'P2P' VIA XFMR (EXISTING)	100	80	3	REFER TO TRANSFORMER SCHEDULE	①	
2	HWP-1 (EXISTING) (5HP)	100	20	3	REFER TO MOTOR WIRING SCHEDULE	VIA VFD ①	
3	HWP-2, STANDBY (EXISTING) (5HP)	100	20	3	REFER TO MOTOR WIRING SCHEDULE	VIA VFD ①	
DISTRIBUTION PANEL "DP4P" SECTION 2 SCHEDULE							PENTHOUSE
277/480 VOLTS		3 PHASE		4 WIRE		* AIC	
MAIN BUS SIZE: 400 AMPS		NEUTRAL: 100%		GROUND BUS: FULL			
MAIN DEVICE: MLO		MOUNTING: SURFACE					
		NOTE: FED THRU LUGS FROM DP4P SECTION 1 INSTALLED UNDER SHELL AND CORE PHASE					
CIRCUIT NUMBER	LOAD ITEM	OVERCURRENT DEVICE			FEEDER SIZE	REMARKS	
		FRAME	TRIP	POLE			
9	AHU-1 (64FLA)	100	100	3	3#4 & 1#6G - 1 1/4" C	VIA VFD	
10	EAHU-1 (50FLA)	100	100	3	3#4 & 1#6G - 1 1/4" C	VIA VFD	
11	CT-1 (20HP)	100	60	3	REFER TO MOTOR WIRING SCHEDULE	VIA VFD	
12	HEAT TRACE	100	20	3		-	
13	AC-1 (1.5HP)	100	20	3	REFER TO MOTOR WIRING SCHEDULE	-	
14	SPARE	100	30	3			
15	SPARE	100	30	3			
16	HRW (1/2HP)	100	20	3	REFER TO MOTOR WIRING SCHEDULE	VIA VFD	
17	CBWP-7 (1.5HP)	100	15	3	REFER TO MOTOR WIRING SCHEDULE	-	
18	CBWP-5 (1HP)	100	15	3	3#10 & 1#10G - 3/4" C	-	
19	CBWP-6 (1HP)	100	15	3	3#10 & 1#10G - 3/4" C	-	
20	SPACE	100	-	3			

From the distribution panelboard schedule, the current equipment can support the new lighting load.

April 9th, 2014

Depth: PHOTOVOLTAIC ARRAY

With the higher and high demand of electrical and fossil energy worldwide, clean and renewable energy takes a bigger part in the building industry. By having photovoltaic system in the building are encouraged by the USGBC. As a national leader in sustainability and innovation, the City of Boston created the Renew Boston Solar map to assist in tracking our community's clean energy progress and meeting Mayor Thomas M. Menino's goal of reducing greenhouse gas emissions by 25% in 2020.

In order to maximize the energy efficient goal of that the company is dedicated in, solar photovoltaic arrays are designed for the building. The study is to determine whether the photovoltaic system will be a good idea for the building with the consideration of the geographic reason and the surrounding conditions. The original design has photovoltaic arrays installed on the roof as well as the building exterior walls with two purposes. One is for energy saving, the other is for research and data collecting. When the building was under design phase, there are no tall buildings close to the site. However when the tenant moved in the building, there is a new construction happened right next to it and are taller than the Fraunhofer building. And the photovoltaic arrays that are located on the west exterior walls may not serve the power supply as well as design.

For building with more than 10 kilowatts in size, the installed price for photovoltaic systems is usually \$4.60/W for commercial buildings. In this case, a single multijunction photovoltaic panel can reach the efficiency of as high as 40%.

Also there is another PV system is installed in the building. The PV panels on the east façade are from the provider called Pythagoras. Pythagoras Solar PVGU are solar glass panels that can be installed within the building envelope that will provide high transparency glazing as well as transferring solar energy into electrical power. It can contribute to achieving LEED points in the areas such as optimizing energy performance, on-site renewable energy, daylight and views.

Array Area	1300 sf
PV rate	100w/sf
Total watt per array	130kw
Total Load usage per year	14.8kw
PV cost/watt	\$1.4/w
PV cost per year	\$14800
Watt save per year	130kw
Conventional Power	\$17619
SAVE	(\$2819)

April 9th, 2014

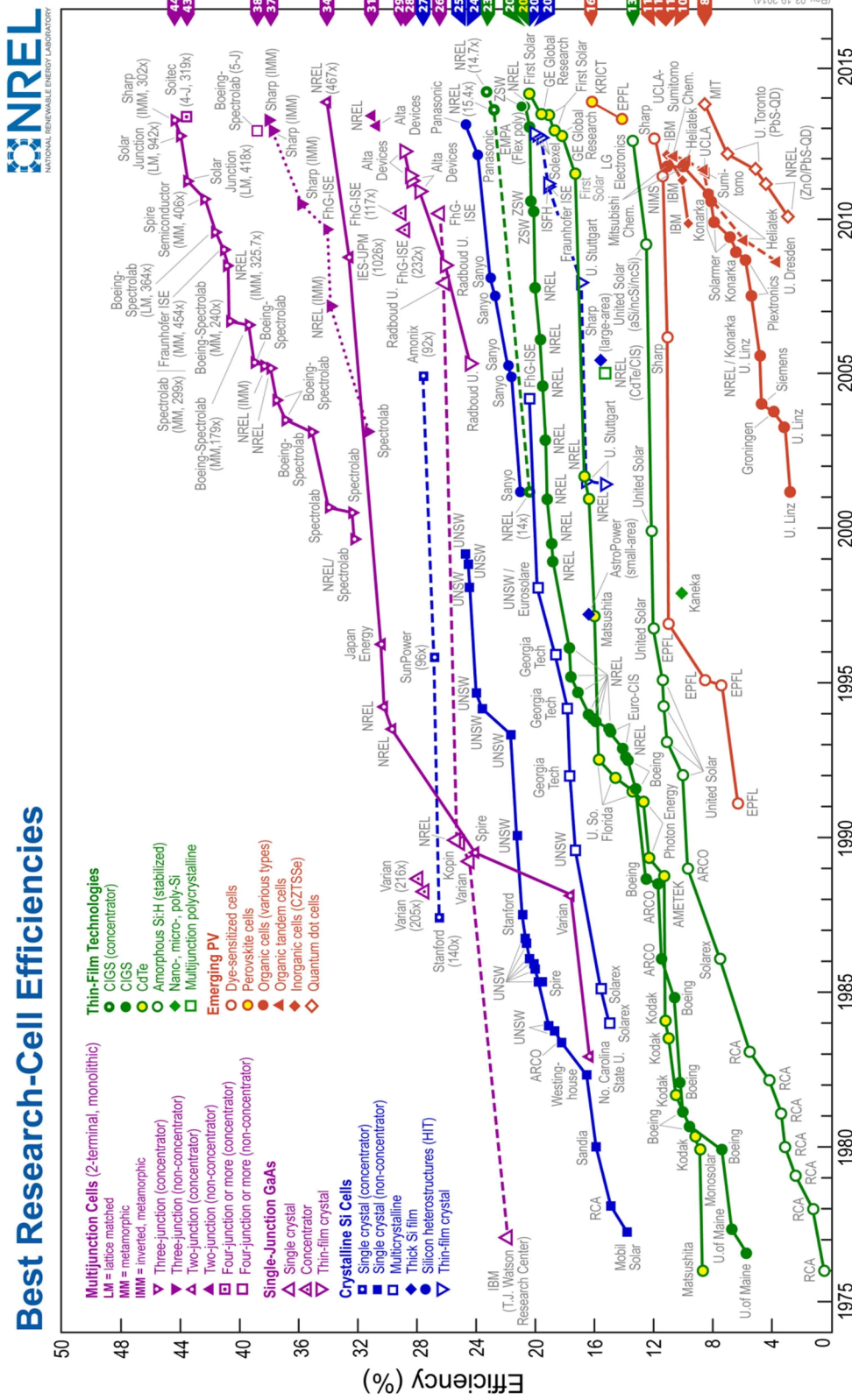

Figure 45

Fraunhofer CSE, Boston MA

references

1. Lighting Criteria:
2. Illumination Engineering Society Handbook, 10th Edition
3. ASHRAE 90.1 Standard (2010)
4. Picture from www.archdaily.com, photo courtesy of ODA
5. <http://gis.cityofboston.gov/solarboston/>
6. <http://www.nrel.gov/ncpv/>

Computer Programs

- AGi32 2014
- AutoCAD 2014
- Autodesk 3ds Max 2014
- Revit

Appendix A

Lighting Fixture Cutsheet

Table of Content

D1

D2

F1

L1

L2

L3

L4

L5

L6

L7

P1

P2

P3

R1

R2

W1

W2

C

ENVIRONMENTALLY FRIENDLY, ENERGY EFFICIENT

- Lumen packages comparable to 26W, 32W, 42W CFL and 2x26W CFL with energy savings up to 35%
- Superior-quality white LED light output using Chip on Board technology
- No harmful ultraviolet or infrared wavelengths
- No lead or mercury

PRODUCT SPECIFICATIONS

Optics

Reflector/Lens: Computer-optimized parabolic reflector with frosted convex lens regressed into cone provides uniform distribution with no striations • Concealed LED array provides superior aesthetic appeal both on and off

Finishes: Low iridescent specular, semi-specular and satin Alzak® finishes available with integral flange of same finish • See reflector options for other colors and finishes

Baffle: White or black painted deep multi-groove aluminum baffle insert with integral white painted flange and frosted convex glass lens

Electrical

LED Light Engine: Compact light source delivers uniform illumination without pixilation, enabling excellent beam control • Consistent fixture-to-fixture color temperature within 3 MacAdam ellipses • Replaceable PC board with quick connector mounts directly to heat sink • CRI> 80

• Light engine mounts directly to heat sink and is easily replaceable • Cast aluminum heat sink integrated directly with housing provides superior thermal management to ensure the long life of LED

LED Driver: Power factor >0.9 • Easily replaceable from above or below the ceiling

• Dimmable via 0-10V protocol, increasing efficiency up to 30% while dimming

• For a list of compatible dimmers, see [LED-DIM](#)

Life: Rated for 50,000 hours at 70% lumen maintenance

Mechanical

Housing: Low profile, universal housing design installs in suspended grid, plaster or drywall

• Integral cast aluminum heat sink conducts heat away from LED light engine

• Driver accessible from above and below ceiling and can be upgraded to accommodate future technology improvements.

Mounting Frame: Heavy gauge steel lower housing ring accommodates ceilings up to 2" thick

• For thicker ceilings; consult factory

Mounting Bracket: Mounting brackets have 3" vertical adjustment and accepts most commercial bar hangers, including our proprietary Tru-Lock bar hangers • Our one-piece Tru-Lock bar hangers have integral T-bar locking screws and alignment notches for locating and locking fixture in the center or 1/4 tile increments

Junction Box: Over size 4" x 6" galvanized steel junction box with (6) 1/2" (2) 3/4" knockouts facilitate quick wiring • Junction box rated for four (4) No. 12 AWG 90° C branch circuit conductors (2-in, 2-out)

Labels and Listings

- UL listed for feed through and damp locations
- UL and cUL, RoHS compliant
- EMI complies with FCC 47, Part 15, Class A
- Energy Star qualified, see back page for designated products
- I.B.E.W. Union made • ARRA Compliant

Warranty: 5 years when used in accordance with manufacturing guidelines.

Product specifications subject to change without notice.

800/1300/1500/1700/2300/2800/3300/4000 LUMEN

4" LED DOWNLIGHT

PARABOLIC LENSED APERTURE

L4 SERIES



Type	Cat. No.
Project: _____	
Notes: _____	

DIMENSIONS

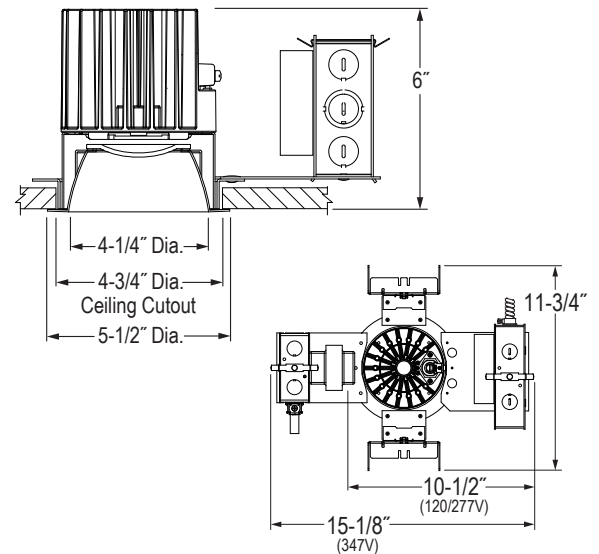

ENGINEERING DATA

Voltage		120V							
Light Engine Lumens		800	1300	1500	1700	2300	2800	3300	4000
CCT		(2700K/3000K/3500K/4000K)							
Input Current		0.075	0.125	0.158	0.183	0.242	0.308	0.300	0.383
Input Wattage		9W	15W	19W	22W	29W	37W	36W	46W
Input Frequency		50/60Hz	50/60Hz	50/60Hz	50/60Hz	50/60Hz	50/60Hz	50/60Hz	50/60Hz
Power Factor		0.9	0.9	0.9	0.9	0.9	0.9	0.9	0.9
Voltage		277V							
Light Engine Lumens		800	1300	1500	1700	2300	2800	3300	4000
CCT		(270K/3000K/3500K/4000K)							
Input Current		0.032	0.054	0.069	0.079	0.105	0.134	0.130	0.166
Input Wattage		9W	15W	19W	22W	29W	37W	36W	46W
Input Frequency		50/60Hz	50/60Hz	50/60Hz	50/60Hz	50/60Hz	50/60Hz	50/60Hz	50/60Hz
Power Factor		0.9	0.9	0.9	0.9	0.9	0.9	0.9	0.9

347 Volt available, consult factory.

ORDERING INFORMATION: Rough-in, reflector and accessories each ordered separately.

Example: **L4-15301-G2-BR**

Rough-in	Light Engine Lumens	Color Temp.	Voltage	Generation	Options
L4	08 800 Lumens	27 2700K	120V	G2 Universal	F Fuse and Fuse Holder
L4	13 1300 Lumens	30 3000K	120V	G2 Universal	CP Chicago Plenum
L4	15 1500 Lumens	30 3000K	120V	G2 Universal	BR Emergency Battery Pack W/ Remote Test Switch
L4	17 1700 Lumens	35 3500K	277V	G2 Universal	*PD Driver compatible with Lutron Programmable Dimming EcoSystem®
L4	23 2300 Lumens	40 4100K	347V	G2 Universal	LDI Lumen Depreciation Indicator (Cannot be Used w/ BR Option)
L4	28 2800 Lumens	40 4100K	347V	G2 Universal	*FDL Forward Phase Dimming Lutron Driver (120V only)
L4	33 3300 Lumens	40 4100K	347V	G2 Universal	
L4	40 4000 Lumens	40 4100K	347V	G2 Universal	

Example: **L400P-CQ-WH**

Reflector	Color Options	Finish	Options
L400P Open Reflector	C Clear G Gold WT Wheat PT Pewter	Low Iridescent Alzak® Finishes: L Specular S Satin Q* Semi-Specular (*Clear only)	WH White Flange WET Wet Location Listing
L400B Baffle	BZ Bronze B Black W White	Blank for white & baffle	

Example: **HB-TL**

Accessories
HB-TL 25" Tru-Lock grid ceiling bar hangers, Pair
HB-52 52" C-Channel Bar Hangers, Pair
HB-28 28" C-Channel Bar Hangers, Pair
LB-27 27" Linear Bar Hangers, Pair
SCA4-* Sloped Ceiling adapter

*Angle must be specified when ordering; Available in 5°, 10°, 15°, 20°, 25°, 30° Example: SCA4-20

■ 800 & 1300 lumen fixtures are universal voltage (120/277V)

◆ Not Available for 4000 Lumens

Rev. 3 10/13



1300 South Wolf Rd • Des Plaines, Illinois 60018
PHONE 800-367-5866 • FAX 888-708-6578
www.junolightinggroup.com

Catalog Number: L4-0840-G2; L400P-CL

PHOTOMETRIC REPORT

Test Number: PR08110161

Total Lumen Output: 567 Lumens

Luminaire Efficacy: 65.0 lm/w (4K)

Luminaire Spacing Criteria: 1.08

Luminaire: Clear specular Alzak® reflector with regressed frosted glass lens.

CIE-Type: Direct



Initial Footcandles

Distance to Illuminated Plane (Feet)	Footcandles		Beam Diameter
	Beam Center	Beam Edge	
6'	11.6	3.5	8.4'
7'	8.5	2.6	9.8'
8'	6.5	2.0	11.2'
9'	5.2	1.6	12.6'
10'	4.2	1.3	14.0'
11'	3.4	1.1	15.4'
12'	2.9	0.9	16.9'
13'	2.5	0.8	18.3'
14'	2.1	0.6	19.7'
15'	1.9	0.6	21.1'

AVERAGE INITIAL FOOTCANDLES

Reflectances: 80% Ceiling, 50% Walls, 20% Floors

Luminaire Spacing	Room Cavity Ratio		
	RCR1	RCR4	RCR8
5' x 5'	25	20	15
6' x 6'	17	14	10
7' x 7'	13	10	8
8' x 8'	10	8	6
9' x 9'	8	6	5
10' x 10'	6	5	4
11' x 11'	5	4	3
12' x 12'	4	3	3

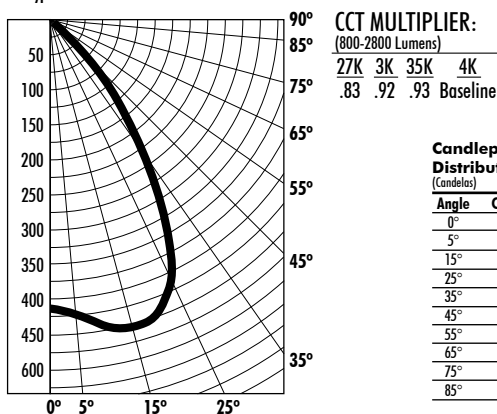

Candlepower Distribution (Candelas)

Angle	Candela	Lumens
0°	417	
5°	423	40
15°	461	131
25°	416	192
35°	233	146
45°	68	53
55°	4	4
65°	0	0
75°	0	0
85°	0	0

Lumiance Data

Angle in Degrees	Candela/M ²
45°	10496
55°	743
65°	0
75°	0
85°	0

Zonal Lumen Summary

Zone	Lumens%	%Fixture
0-30°	363	64.2
0-40°	510	90.1
0-60°	566	100.0
0-90°	566	100.0
90-180°	0	0.0
0-180°	566	100.0

COEFFICIENTS OF UTILIZATION - % (Zonal Cavity Method)

Effective Floor Reflectance 20%

PCC	80			70			50			30			10			0			
	PW	70	50	30	10	0	PW	70	50	30	10	0	PW	70	50	30	10	0	
0	119	119	119	119	116	116	116	116	111	111	111	111	106	106	106	102	102	102	100
1	113	110	108	105	111	108	106	104	104	102	101	100	99	98	97	96	95	93	
2	107	102	98	94	105	100	96	93	97	94	91	94	91	89	91	89	87	86	
3	101	95	89	85	99	93	88	84	90	86	83	88	85	82	86	83	80	79	
4	96	88	82	77	94	87	81	77	84	80	76	82	78	75	80	77	74	73	
5	90	81	75	71	89	80	75	70	79	74	70	77	73	69	75	72	68	67	
6	85	76	69	65	84	75	69	65	73	68	64	72	67	64	71	67	63	62	
7	81	71	64	60	79	70	64	60	69	63	59	67	63	59	66	62	59	57	
8	76	66	60	55	75	66	59	55	64	59	55	63	58	55	62	58	54	53	
9	72	62	56	51	71	61	55	51	60	55	51	59	54	51	59	54	51	49	
10	68	58	52	48	67	58	52	48	57	51	48	56	51	47	55	51	47	46	

Catalog Number: L4-4035-G2; L400P-CL

PHOTOMETRIC REPORT

Test Number: PR08110261

Total Lumen Output: 2746 Lumens

Luminaire Efficacy: 60.3 lm/w (35K)

Luminaire Spacing Criteria: 1.07

Luminaire: Clear specular Alzak® reflector with regressed frosted glass lens.

CIE-Type: Direct



Initial Footcandles

Distance to Illuminated Plane (Feet)	Footcandles		Beam Diameter
	Beam Center	Beam Edge	
6'	56.2	17.0	8.4'
7'	41.3	12.5	9.8'
8'	31.6	9.5	11.2'
9'	25.0	7.5	12.6'
10'	20.2	6.1	14.0'
11'	16.7	5.0	15.4'
12'	14.1	4.2	16.8'
13'	12.0	3.6	18.2'
14'	10.3	3.1	19.6'
15'	9.0	2.7	21.0'

AVERAGE INITIAL FOOTCANDLES

Reflectances: 80% Ceiling, 50% Walls, 20% Floors

Luminaire Spacing	Room Cavity Ratio		
	RCR1	RCR4	RCR8
5' x 5'	121	97	72
6' x 6'	84	67	50
7' x 7'	62	49	37
8' x 8'	47	38	28
9' x 9'	37	30	22
10' x 10'	30	24	18
11' x 11'	25	20	15
12' x 12'	21	17	13

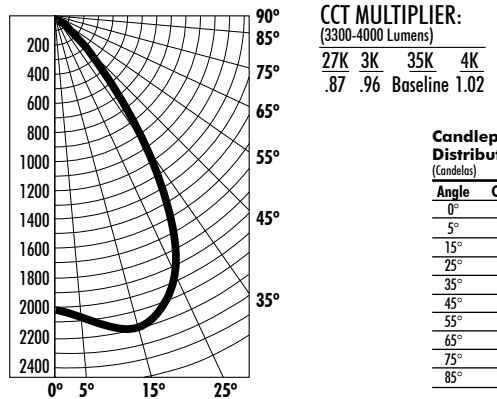

Candlepower Distribution (Candelas)

Angle	Candela	Lumens
0°	2024	
5°	2063	197
15°	2205	625
25°	1988	920
35°	1116	701
45°	322	249
55°	41	36
65°	6	6
75°	0	0
85°	0	0

Lumiance Data

Angle in Degrees	Candela/M ²
45°	49732
55°	7729
65°	1524
75°	3292
85°	0

Zonal Lumen Summary

Zone	Lumens%	%Fixture
0-30°	1742	63.5
0-40°	2443	89.1
0-60°	2729	99.5
0-90°	2743	100.0
90-180°	0	0.0
0-180°	2743	100.0

COEFFICIENTS OF UTILIZATION - % (Zonal Cavity Method)

Effective Floor Reflectance 20%

PCC	80			70			50			30			10			0			
	PW	70	50	30	10	0	PW	70	50	30	10	0	PW	70	50	30	10	0	
0	118	118	118	118	116	116	116	116	110	110	110	110	106	106	106	101	101	101	99
1	112	110	107	105	110	107	105	103	103	101	100	100	98	97	96	95	94	92	
2	106	101	97	93	104	100	96	92	96	93	90	93	91	88	91	88	87	85	
3	101	94	88	84	99	92	88	84	90	86	82	87	84	81	85	82	80	78	
4	95	87	81	77	93	86	80	76	84	79	75	82	78	74	80	76	73	72	
5	90	81	75	70	88	80	74	70	78	73	69	76	72	68	75	71	68	66	
6	85	75	69	64	83	74	68	64	73	68	64	71	67	63	70	66	63	61	
7	80	70	64	59	79	69	63	59	68	63	59	67	62	58	66	61	58	57	
8	76	66	59	55	74	65	59	55	64	58	54	63	58	54	62	57	54	52	
9	72	61	55	51	70	61	55	51	60	54	51	59	54	50	58	54	50	49	
10	68	58	51	47	67	57	51	47	56	51	47	56	51	47	55	50	47	45	

Energy Star Qualified:

Product #		Fixture Configurations = Energy Star	
	L4-(XX)(YY)(Z); L400P-C(F)	Lumen Package: CCT: Voltage: Reflector Finish:	800/1300/1500/1700/2300/2800/3300/4000 (XX = 08, 13, 15, 17, 23, 28, 33, 40) 2700K / 3000K / 3500K / 4000K (YY = 27, 30, 35, 40) 120V / 277V (Z = 1, 2) Specular / Satin / Semi-Specular (F = L, S, Q)
	347V Only L4-(XX)(YY)3; L400P-C(F) L400P-C(F)	Lumen Package: CCT: Reflector Finish:	1500/1700/2300/2800/3300/4000 (XX = 15, 17, 23, 28, 33, 40) 2700K / 3000K / 3500K / 4000K (YY = 27, 30, 35, 40) Specular / Semi-Specular (F = L, Q)

Fixtures tested to IES recommended standard for solid state lighting per LM-79-08. Photometric performance on a single unit represents a baseline of performance for the fixture. Results may vary in the field.



1300 S. Wolf Road • Des Plaines, IL 60018 • Phone (800) 367-5866 • Fax (888) 708-6578
Visit us at www.junolightinggroup.com

DL LED XSM/4

recessed LED downlight

LED
0-050

FULLY SUSTAINABLE – FULLY SUSTAINABLE – FULLY SUSTAINABLE – FULLY SUSTAINABLE – FULLY SUSTAINABLE – FULLY SUSTAINABLE – FULLY SUSTAINABLE

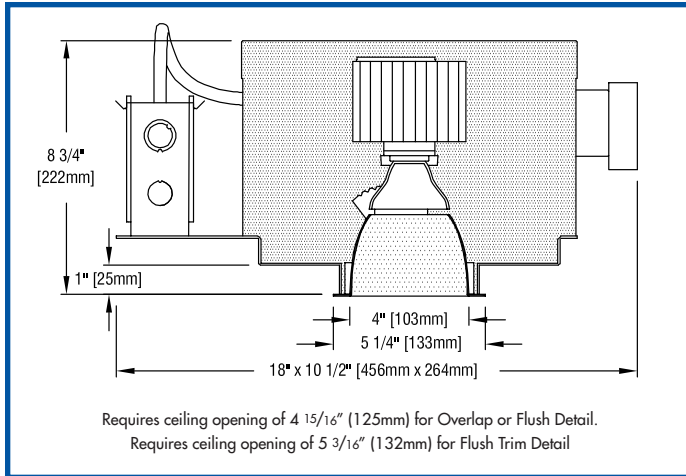

FEATURES

DL LED XSM/4 is an efficient, 4" aperture, LED downlight powered by one of a number of Xicato® LED modules – including Artist Series and Vibrant Series modules – all of which are distinguished by extraordinary color consistency (within 1 x2-step MacAdam ellipse). See tables on the reverse for wattages and efficacies.

Luminaire includes an internal reflector to produce a 20° spot, 40° flood or 60° wide flood beam spread. To allow beam spread to be changed after installation, internal reflectors are also available as accessories.

Precise external reflector design minimizes aperture brightness and provides a shielding angle of 40°. Recess depth is 8 3/4".

Standard driver of 2000-lumen Artist Series model permits dimming to 10% by a 0-10V dimmer on 120-volt or 277-volt service. Standard driver for all other models permits dimming to 1% by a 0-10V dimmer on 120-volt or 277-volt service.

An optional integral holder permits the use of one or two of a number of Optical Accessories including lenses and color filters.

External reflectors are available in three clear natural aluminum finishes — semi-specular (C), slightly diffuse (V) or fully diffuse (EC) — as well as champagne gold or black Alzak®. Other finishes available on special order.

A LightPlate trim may be used instead of an external reflector.

Luminaire includes a pair of mounting bars (3/4" x 27" C channel). Specialty bars for wood joists and T-bar installations are also available.

APPLICATIONS

Luminaire is recommended for downlighting in commercial, retail and residential spaces.

Luminaire is listed as an inherently protected luminaire and does not require a thermal protector. Luminaire is prewired, approved for ten #12 wire 90°

branch circuit pull-through wiring and suitable for use in a fire rated ceiling. Luminaire is listed for Damp Location and is RoHS compliant. Removal of the reflector allows access to the junction box.



SPACING REQUIREMENT

The 2000A model of this luminaire must be spaced 36" apart and 18" from walls, and must have 1/2" clearance above housing.

MODIFICATIONS AVAILABLE ▼ See next page

PRODUCT CODE

For complete product code, list basic unit and select one item from each following box.

Basic UnitDL-XSM2-4DL

Light Output

700 lumens / CRI 97 Artist.....	L07A
1000 lumens / CRI 97 Artist.....	L10A
1000 lumens / CRI 80+.....	L10S
1300 lumens / CRI 97 Artist.....	L13A
1500 lumens / CRI 80+ Vibrant 3000K only	L15V
1500 lumens / CRI 80+.....	L15S
2000 lumens / CRI 97 Artist ... Note: Spacing Requirements	L20A
2200 lumens / CRI 80+ Vibrant 3000K only.....	L22V
2200 lumens / CRI 80+.....	L22S

Light Color

2700 K.....	- 27K
3000 K.....	- 30K
3500 K.....	- 35K
4000 K.....	- 40K

Beam Spread Reflector (specify one to ship with fixture)

20° spot	- 20D
40° flood	- 40D
60° wide flood	- 60D

Voltage: standard luminaire operates on either 120 or 277 service

Reflector Color and Detail	Overlap	Flush	Trim Flush*
Semi-specular Clear.....	COL.....	CFL.....	CTF
Slightly diffuse Clear.....	VOL.....	VFL.....	VTF
Fully diffuse Clear.....	ECOL.....	ECFL.....	ECTF
Champagne Gold.....	GOL.....	GFL.....	GTF
Black.....	BOL.....	BFL.....	BTF

Other reflector finishes available on special order.

Standard reflector flange continues reflector finish. White painted flanges and custom painted flanges are available on special order. Add WF (white flange) or CCF (custom color flange).

*Trim Flush reflector trim requires the use of a plaster ring Accessory (see below).

A LightPlate may be ordered instead of a standard reflector above (see next page).

LightPlate **Downlight Spot**, white.....DP-OL.....DP-TF

Custom painted trims for LightPlate are available on special order. Add -CC

OPTIONS

Specify by adding to the basic unit.

Dimmable ...2000A models: standard driver dimmable to 10% with 0-10V dimmer on 120 or 277 volt service **all other models:** standard driver dimmable to 1% with 0-10V dimmer on 120 or 277 volt service

Dimmable to 1% with Lutron driver, compatible with Lutron 3-wire fluorescent dimmer or EcoSystem Bus Control and suitable for 120 or 277 volt operation D3D-LU

Integral holder for one or two Optical Accessories (see over) G

Emergency battery pack Fixture footprint increases to 21 1/8" x 10 1/2" EM

ACCESSORIES

Specify as separate line item.

Plaster ring allows use of 4 7/8" OD Trim Flush (-TF) reflector in sheetrock ceiling: 5 3/16" dia hole required TF RING/4

EXTRA REFLECTORS

Specify as separate line items.

20° spot reflector	XSM-REF20
40° flood reflector	XSM-REF40
60° wide flood reflector	XSM-REF60

OPTICAL ACCESSORIES

▼ See next page



41-50 22ND STREET, LIC NY 11101 TEL 718.685.0700 FAX 718.786.8530 www.epl.com
U.S. Patent No. US 7,744,256 B2 (June 29, 2010)

©Copyright, Edison Price Lighting 2013

11:13

MODIFICATIONS AVAILABLE

Contact factory with quantity for pricing; orders may require shop drawing approval.

- +DOD:** luminaire suitable for **high humidity** environments; add +DOD to Product Code.
- +MAR:** reflector suitable for **marine** environments; add +MAR to Product Code.
- +TR:** reflector prepared for **top relamping**; add +TR to Product Code.

LIGHTPLATE LightPlate may be used instead of standard reflectors.

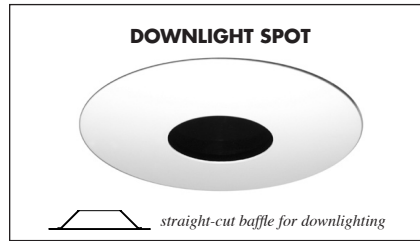

OPTICAL ACCESSORIES Specify as separate line

All are 3 3/4" (95mm) diameter.
Lenses and filters are glass; screens are aluminum.

prismatic lens (Solite)	PLS/3.75	color filters	surprise pink	PNK/3.75
55° spread lens	LENS/3.75		daylight blue	DAY/3.75
40° x 70° spread lens	LENS/3.75-4070		amber	AMB/3.75
beam smoother	CLR/3.75		blue	BLU/3.75
33% light reduction screen	SCR33/3.75		green	GRN/3.75
50% light reduction screen	SCR50/3.75		red	RED/3.75

PHOTOMETRIC REPORT (tested per IESNA LM-79-2008)

(LTL) Report No. 226175. Original Luminaire Testing Laboratories, Inc. (LTL) test reports furnished upon request.

Luminaire recessed LED round downlight with semi-specular clear aluminum reflector
 Lamp Xicato XSM LED with 40° beam spread integral reflector, 3000K CCT, 1500 lumens
 Lamp Life rated 50,000 hours based on L70/B50 criteria. LM80 report by LED manufacturer furnished upon request
 Spacing Criteria 0.5 (0.7 for 60° reflector, 0.4 for 20° reflector)
 Luminaire light output..... 1244 lumens

CANDLEPOWER DISTRIBUTION (Candela)

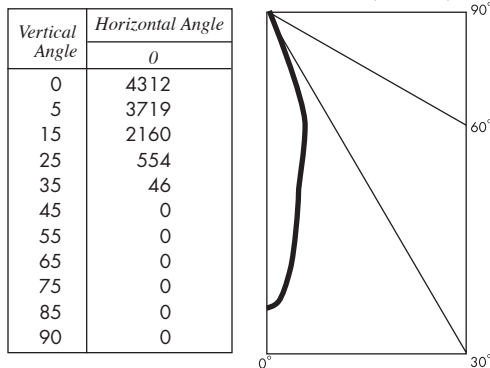

STANDARD (0-10V DIMMING) DRIVER INFORMATION UL Class 2, dry and damp location

Voltage	120	277
Input Watts (700A/1000A/1300A/2000A/1000/1500/2000/2200 lumens)	16/21/32/47/15/23/34	16/21/32/47/15/23/34
Input Current (A) (700A/1000A/1300A/2000A/1000/1500/2000/2200 lumens)	.13/.18/.27/.39/.13/.19/.28	.06/.08/.12/.17/.05/.08/.12
Output Current (mA)	500/700/1050	500/700/1050
Min. Power Factor	>0.9	>0.9
Operating Temperature Range (F)	-4 to 122	-4 to 122

ZONAL LUMEN SUMMARY

Zone	Lumens	% Fixture
0 - 30°	1196	96.1
0 - 40°	1243	99.9
0 - 60°	1244	100.0
0 - 90°	1244	100.0
90 -180°	0	0.0
0 -180°	1244	100.0

LIGHT OUTPUT MULTIPLIER

LED Light Engine	Light Output Multiplier	EM Light Output Multiplier (90-minute run)
700 Lumens Artist	.45*	.12*
1000 Lumens Artist	.57*	.16*
1300 Lumens Artist	.76*	.16*
2000 Lumens Artist	1.10*	.26*
1000 Lumens standard	.66*	.26*
1500 Lumens standard & Vibrant	1	.40*
2200 Lumens standard & Vibrant	1.30*	.40*

*estimated values

LUMINANCE DATA

Vertical Angle	Candelam ²
45	0
55	0
65	0
75	0
85	0

REFLECTOR COLOR MULTIPLIERS

Semi-specular clear (C)	1
Slightly diffuse clear (V)	.95
Fully diffuse clear (EC)	.88
Champagne gold clear (G)	.95
Black (B)	.49

LUMINAIRE LIGHT OUTPUT AND EFFICACY (40° beam spread integral reflector)

LED Light Engine	Luminaire Light Output	Luminaire Efficacy (lms/watt)	System Wattage
700 Lumens Artist	556*	36	16
1000 Lumens Artist	704*	34	21
1300 Lumens Artist	945*	29	32
2000 Lumens Artist	1363*	29	47
1000 Lumens standard	826*	55	15
1500 Lumens standard & Vibrant	1244	53	23
2200 Lumens standard & Vibrant	1616*	48	34

*estimated values

FXLED150SF/PCS

Ultra high output, high efficiency LED floodlight with wide NEMA type 6H x 6V beam spread. Patent Pending airflow technology ensures long LED and driver lifespan. Use for general and security lighting for large areas, building facades, signs and landscapes.

Color: Bronze

Weight: 25.0 lbs

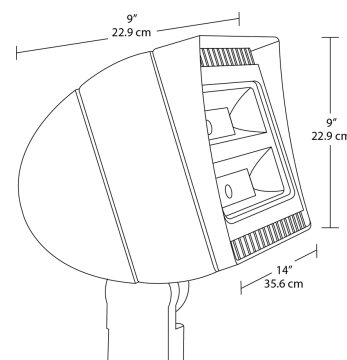

LED Info

Watts: 150W
 Color Temp: 5000K (Cool)
 Color Accuracy: 65
 L70 Lifespan: 100000
 LM79 Lumens: 14,440
 Efficacy: 93 LPW

Driver Info

Type: Constant Current
 120V: 1.31A
 208V: N/A
 240V: N/A
 277V: N/A
 Input Watts: 155W
 Efficiency: 97%

Technical Specifications

UL Listing:

Suitable for wet locations. Suitable for mounting within 1.2m (4ft) of the ground.

Lifespan:

100,000-hour LED lifespan based on IES LM-80 results and TM-21 calculations.

IP Rating:

Ingress Protection rating of IP66 for dust and water.

LEDs:

Multip-chip, high-output, long-life LEDs

Photocell:

120V Swivel Photocell Included. Photocell is compatible with 120V.

Drivers:

Two Drivers, Constant Current, Class 2, 2000mA, 100-277V, 50-60Hz, 1.1A, Power Factor 99%

THD:

5.3% at 120V, 13.1% at 277V

Ambient Temperature:

Suitable for use in 40°C (104°F) ambient temperatures.

Effective Projected Area:

EPA = 2

Cold Weather Starting:

The minimum starting temperature is -40°F/-40°C.

Thermal Management:

Superior thermal management with external Air-Flow fins.

Housing:

Die-cast aluminum housing and door frame

Mounting:

Heavy-duty Slipfitter for 2 3/8"OD pipe.

Color Consistency:

7-step MacAdam Ellipse binning to achieve consistent fixture-to-fixture color.

Color Stability:

LED color temperature is warranted to shift no more than 200K in CCT over a 5 year period.

Color Uniformity:

RAB's range of CCT (Correlated Color Temperature) follows the guidelines of the American National Standard for Specifications for the Chromaticity of Solid State Lighting (SSL) Products, ANSI C78.377-2011.

Reflector:

Specular, vacuum-metalized polycarbonate

NEMA Type:

6H x 6V

Field & Beam Angles:

Horizontal Beam Angle (50%): 91.8°, Vertical Beam Angle (50%): 73.5° Horizontal Field Angle (10%): 121.0°, Vertical Field Angle (10%): 108.0°

Gaskets:

High-temperature silicone gaskets

Finish:

Our environmentally friendly polyester powder coatings are formulated for high-durability and long-lasting color, and contains no VOC or toxic heavy metals.

RAB
LIGHTING

Tech Help Line: 888 RAB-1000

Email: sales@rabweb.com

On the web at: www.rabweb.com

FXLED150SF/PCS - continued

Green Technology:

Mercury and UV free, and RoHS compliant. Polyester powder coat finish formulated without the use of VOC or toxic heavy metals.

IESNA LM-79 & LM-80 Testing:

RAB LED luminaries have been tested by an independent laboratory in accordance with IESNA LM-79 and LM-80, and have been received the Department of Energy "Lighting Facts" label.

DLC Listed:

This product is on the Design Lights Consortium (DLC) Qualified Products List and is eligible for rebates from DLC Member Utilities.

Replacement:

The FXLED150 replaces 400W Metal Halide Floodlights.

California Title 24:

FXLED150 complies with California Title 24 building and electrical codes.

Warranty:

RAB warrants that our LED products will be free from defects in materials and workmanship for a period of five (5) years from the date of delivery to the end user, including coverage of light output, color stability, driver performance and fixture finish.

Patents:

The design of FXLED150 is protected by patents pending in US, Canada, China, Taiwan and Mexico.

Country of Origin:

Designed by RAB in New Jersey and assembled in the USA by RAB's IBEW Local 3 workers.

Buy American Act Compliant:

This product is a COTS item manufactured in the United States, and is compliant with the Buy American Act.

Recovery Act (ARRA) Compliant:

This product complies with the 52.225-21 "Required Use of American Iron, Steel, and Manufactured Goods-- Buy American Act-- Construction Materials (October 2010).

Trade Agreements Act Compliant:

This product is a COTS item manufactured in the United States, and is compliant with the Trade Agreements Act.

GSA Schedule:

Suitable in accordance with FAR Subpart 25.4.



Bionic Modular 4" System Recessed Linear Seamless

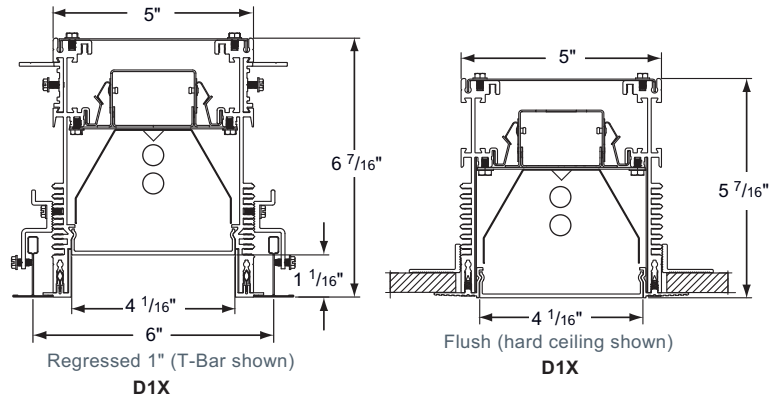
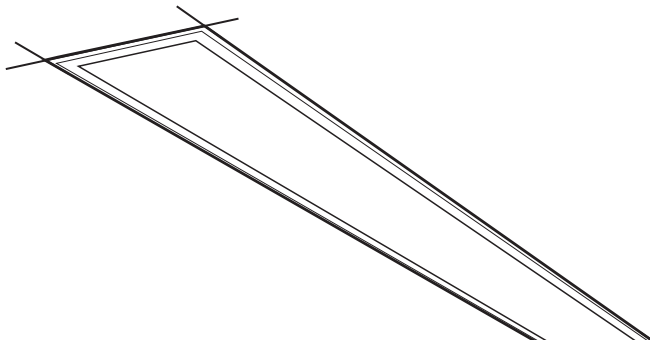

ordering - Bionic STANDARD system – SEAMLESS lamping (BIO-SM)

series/ style	lamp rows	nominal length	shielding	color/finish*	distribution	circuiting	voltage	ceiling system	options
						SC			
Bio-SM	1SM*	02'	ABW* acrylic batwing lens	TMW† textured matte white	D1X* symmetric extended performance (ABW lens only)	SC single circuit	120	X1† exposed T-bar 15/16	EML*
FLSH flush lens	1SMHO* *T ₅ lamp	03'		YGW gloss white			277	X1m† exposed T-bar 9/16	EMH*
REG 1" regressed lens		04'	SAL satin acrylic lens	Y_ premium color	*1 lamp only - utilizes Fusion Optics		347†	X2† dimensional T-bar Armstrong Interlude®	DM
		06'		CC custom color			UNV*†	X6 slot grid	RSE
		08'	SPL silver parabolic louver				*120-277 †not available with MR16's	X3 hard ceiling flange trim	10THD
		R_*						X7BF hard ceiling (trimless mud-over backer flange)	B_
		*row length						M mixed ceiling (contact factory)	M1 12" MR16 module (adj.) 1/50w (max) lamp
			*D1X distribution only	*indicates color of flange trim †standard				†Techzone™ compatible	M2 12" MR16 module (adj.) 2/50w (max) lamp
									M4 cross MR16 module (adj.) 1/50w (max) lamp
									C2 90° 2-way corner w/acrylic lens
									C3 T-shape 3-way connector, non-luminous
									CX cross 4-way connector, non-luminous
									C8 wall-to-ceiling connector

Applications Lobbies, hallways, open offices, small offices

Features A comprehensive 4" Recessed Linear system. See Perimeter and Wall Wash for other distributions.

Construction Universal housing for easy installation, reflectors are made from formed steel or specular aluminum and made of lightweight extruded aluminum. Highly adjustable sliding T- and L-bar brackets for precise ceiling alignment and multiple installation options. Patent pending double dovetail channel for superior alignment along continuous runs.

Finish The trim is textured matte white (TMW) or optional gloss white (YGW) using polyester powder paint. Refer to Controls and Options section for paint colors.

Electrical T8 fixtures have instant-start electronic ballasts with less than 20% THD. Fixtures are U.L. Damp labeled (non emergency) and I.B.E.W. manufactured. Maximum ballast size available: 1.7"W x 1.18"H.

Options EML: emergency battery (600-700 lumens); EMH: emergency battery (1100-1400 lumens); DM: dimming (consult factory); RSE: rapid-start electronic; 10THD: ballast with < 10% total harmonic distortion; B_: specific ballast, specify manufacturer and catalog number (consult factory); FH: fixture fusing slow blow; M1: 12" MR16 module with one (1) adjustable 50w (max) lamp; M2: 12" MR16 module with two (2) adjustable 50w (max) lamps; M4: Cross MR16 module with one (1) adjustable 50w (max) lamp; C2: 90° 2-way corner with acrylic lens; C3: T-shape 3-way connector, non-luminous metal; CX: cross 4-way connector, non-luminous metal; C8: wall-to-ceiling connector with acrylic lens

Prudential reserves the right to change design specifications or materials without notice.

Recessed Linear Bionic Modular 4" System

photometric data (ABW + D1X)

BIO-FLSH-SMT5-04'-ABW-TMW

Report # Lo8u0711 D=80.90% I=0.0%
 Spacing Criteria: Along 1.16; Across 1.62
 Lamp Lumens: 2600 Input Watts: 32.75

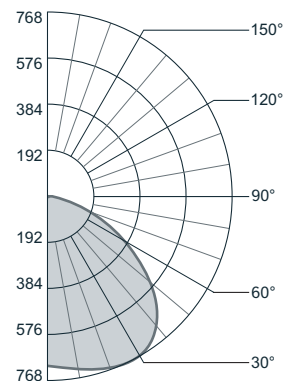

Candlepower Summary

Vertical Angle	Horizontal Angle				
	0°	22.5°	45°	67.5°	90°
0	661	661	661	661	661
5	655	658	662	667	671
10	640	648	664	680	689
15	617	632	666	695	708
20	587	611	663	704	721
25	550	586	655	710	733
30	507	555	642	711	737
35	475	520	624	701	726
40	461	480	597	670	685
45	412	437	558	615	617
50	363	388	508	536	521
55	315	340	452	452	429
60	271	285	381	358	335
65	224	225	301	269	251
70	182	166	222	192	179
75	86	110	146	125	117
80	48	61	80	70	66
85	20	26	32	30	29
90	0	0	0	0	0

Zonal Lumen Summary

Zone	% Lamp	% Luminaire
0-90	80.90	100.00
90-180	00.00	00.00

Efficiency = 80.90%

Luminance Summary (cd/m²)

Angle	0°	45°	90°
45	4187	6436	7116
55	3853	6427	6100
65	3512	5809	4844
75	2710	4601	3687
85	1872	2994	2714

Coefficients of Utilization (%)

Floor effective floor cavity reflectance = .20
 Ceiling 80 70 50
 Wall 70 50 30 10 70 50 30 10 50 30 10

RCR	0	1	2	3	4	5	6	7	8	9	10
0	96	96	96	96	94	94	94	94	90	90	90
1	88	84	81	78	86	82	79	76	79	76	74
2	80	73	68	63	78	72	67	63	69	65	61
3	73	64	58	53	71	63	57	52	61	55	51
4	67	57	50	44	65	56	49	44	54	48	43
5	61	51	43	38	60	50	43	38	48	42	37
6	56	46	38	33	55	45	38	33	43	37	33
7	52	41	34	29	51	41	34	29	39	33	29
8	49	38	31	26	47	37	30	26	36	30	26
9	45	34	28	23	44	34	27	23	33	27	23
10	42	32	25	21	41	31	25	21	30	25	21

Snap-in ceiling options

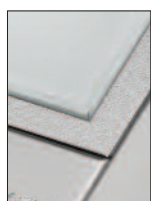

X1 T-Bar 15/16"



X1m T-Bar 9/16"



X2 Interlude



X6 slot grid



X3 hard ceiling

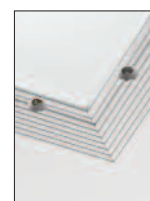

X7BF hard ceiling mud-over

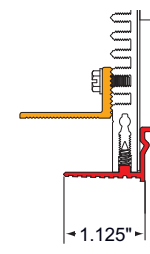
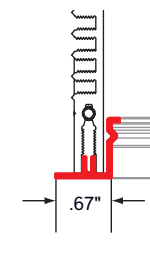
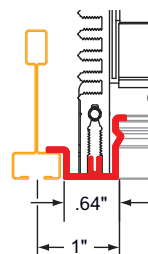
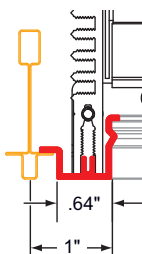
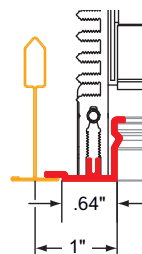
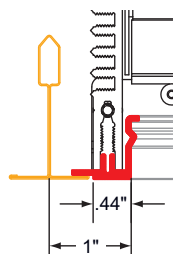

Connectors

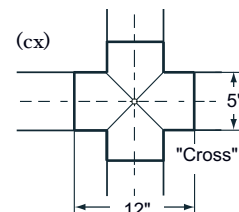
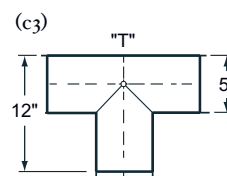
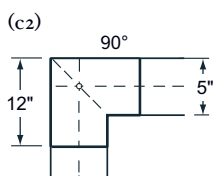
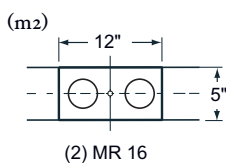
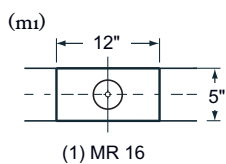



Bionic Modular 4" System Recessed

Seamless

application

Install Options Suspension

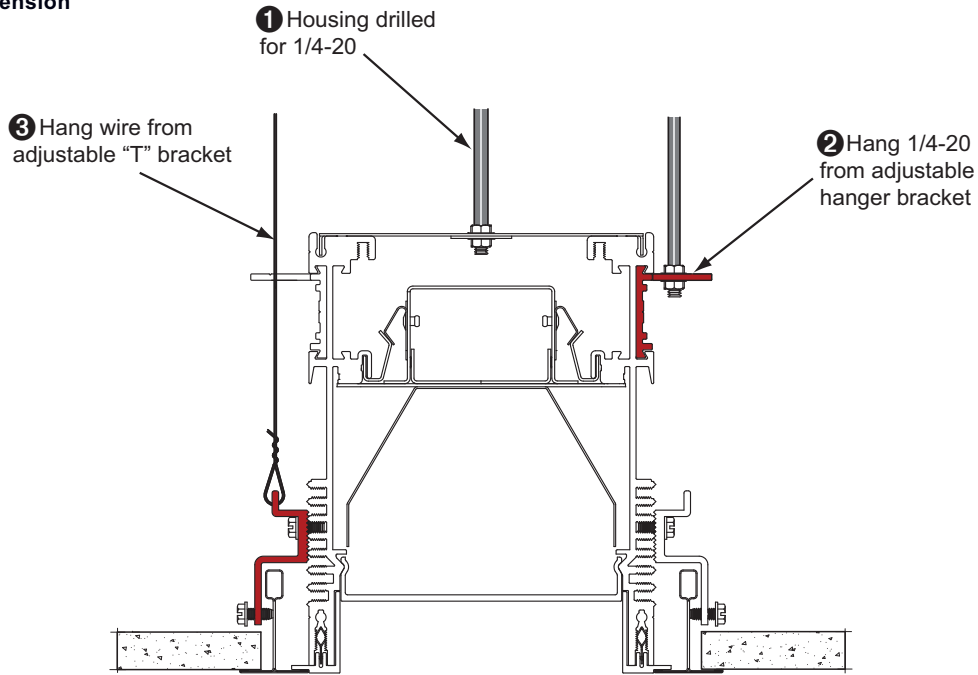

Dovetail Installation Detail

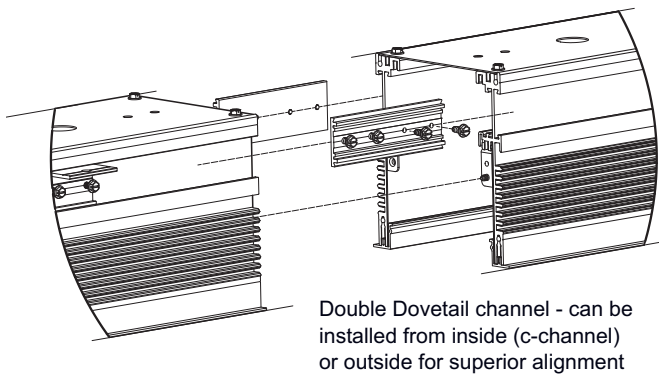

Hanging Drywall Detail

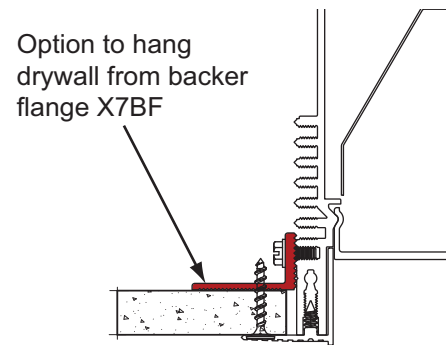

Mounting Detail (1) Housing Detail for 1/4"-20

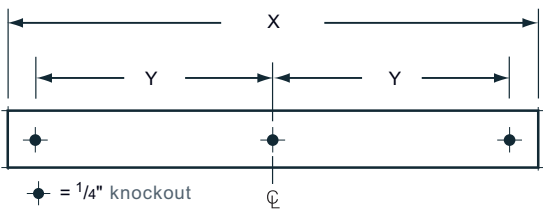

Mounting Conversion Chart

X=2'	Y=9" from centerhole
X=3'	Y=15"
X=4'	Y=21"
X=5'	Y=27"
X=6'	Y=33"
X=7'	Y=39"
X=8'	Y=45"

Prudential reserves the right to change design specifications or materials without notice.

Recessed Bionic Modular 4" System

application

MR16 cross section

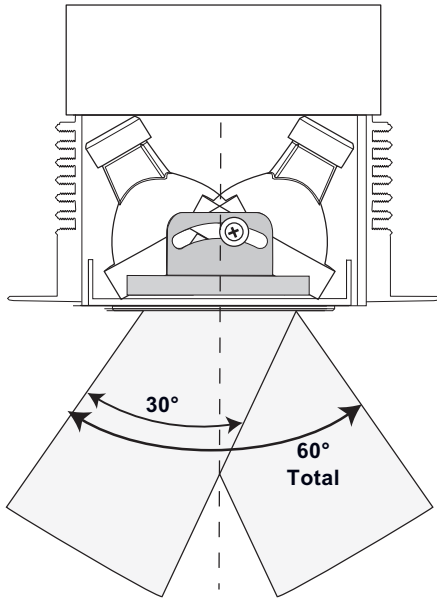

Max. tilt angle of 30°
Max. rotation of 363°

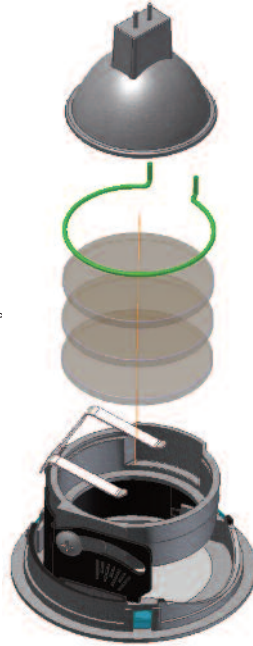

MR16 module holds up to 3 lens' and a lens locking ring allows for precise settings to be maintained during lamp changes

Bionic Modular System



BIONIC SEAMLESS RUN INFORMATION

nominal run length (ft.)	Seamless T5/T5HO			unlit ends (inches)
	lamp quantity			
	2'	3'	4'	
6		2		1.2
7		1	1	1.3
8			2	1.4
9		3		1.8
10		2	1	1.9
11		1	2	2.0
12		4		2.4
13	1	1	2	2.5
14		2	2	2.6
15		1	3	2.7
16			4	2.8
17		3	2	3.2
18	1		4	3.3
19		1	4	3.4
20			5	3.5
21		7		4.3
22		2	4	4.0
23		1	5	4.1
24			6	4.2
25		3	4	4.6
26		2	5	4.7
27		1	6	4.8
28			7	4.9
29	1	1	6	5.3
30		2	6	5.4
31		1	7	5.5
32			8	5.6
33		3	6	6.0
34		2	7	6.1
35		1	8	6.2
36			9	6.3
37	1	1	8	6.7
38		2	8	6.8
39		1	9	6.9
40			10	7.0
41		3	8	7.5
42		2	9	7.5
43		1	10	7.6
44			11	7.7
45	1	1	10	8.1
46		2	10	8.3
47		1	11	8.3
48			12	8.4
49		3	10	8.9
50		2	11	9.0

Prudential reserves the right to change design specifications or materials without notice.

FINELITE



BUY AMERICAN ACT OF 2009 COMPLIANT

High Performance Wall (HPW-LED)



HPR-LED Collection
2011 IES Progress
Report Selection

Date

Project

Type

Comments



DESCRIPTION

HPW-LED is a high performance recessed asymmetric LED wall wash that delivers excellent visual comfort and uniform vertical illumination for school and office applications.



SHIELDING:

HPW-LED is standard with a frosted lens for glare-free lighting and a smooth distribution on the vertical surface. All lenses are UV-stabilized and impact resistant virgin acrylic.

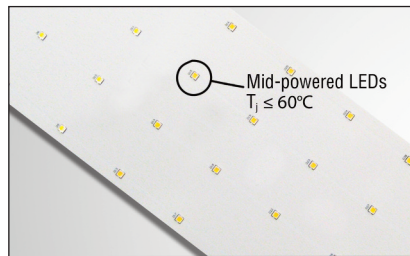

THERMAL MANAGEMENT:

Mid-powered LEDs allow heat to be fully dissipated without the need for additional heat sinks.

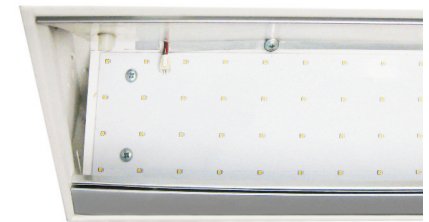

100% SERVICEABLE FROM BELOW:

The light engine and driver can be easily changed from below ceiling – and they are simple to install.

ORDERING GUIDE

Sample Number: HPW-LED - 4' - FR - LED - 4000K - 277 - SC - C1





FINELITE

High Performance Wall (HPW-LED)

PHOTOMETRY

HPW-1-LED
82.5 Lumens Per Watt
3070 Lumens/37.2 Watts
CRI: 82
R9: 5
CCT: 4000K
ITL LM79 Report 74757

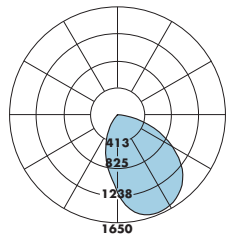
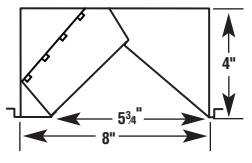

— Refer to www.finelite.com for additional photometry and product information.

CANDLEPOWER SUMMARY						
	0.0	67.5	45	22.5	90	Flux
0	1190	1190	1190	1190	1190	
5	1380	1258	1325	1346	1184	112
15	1573	1323	1477	1546	1128	319
25	1608	1317	1486	1575	1025	470
35	1551	1215	1395	1510	883	545
45	1397	1039	1232	1356	716	545
55	1135	828	1002	1109	535	479
65	772	580	700	760	347	356
75	388	331	377	400	178	198
85	52	82	71	64	42	45
90	0	0	0	0	0	

PHOTOMETRY

HPW-1-LED
79.7 Lumens Per Watt
2980 Lumens/37.4 Watts
CRI: 84
R9: 15
CCT: 3500K
ITL LM79 Report 74756

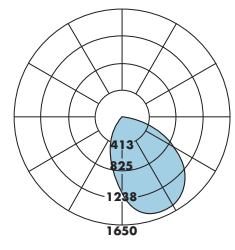
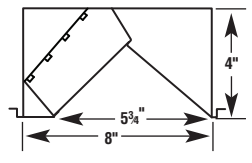

— Refer to www.finelite.com for additional photometry and product information.

CANDLEPOWER SUMMARY						
	0.0	67.5	45	22.5	90	Flux
0	1155	1155	1155	1155	1155	
5	1338	1223	1285	1309	1152	109
15	1528	1286	1434	1499	1098	311
25	1565	1279	1443	1532	998	458
35	1512	1177	1357	1470	861	531
45	1358	1009	1195	1320	696	529
55	1097	797	973	1071	520	464
65	744	556	678	736	338	344
75	382	316	363	378	175	191
85	52	76	73	63	42	44
90	0	0	0	0	0	

CEILING SYSTEM INFORMATION

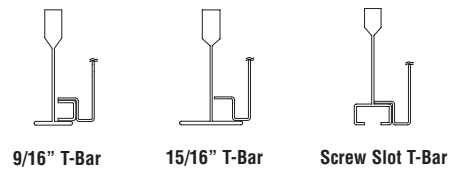

WIRING ACCESS DETAIL

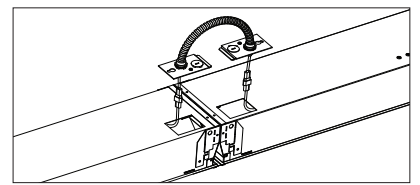
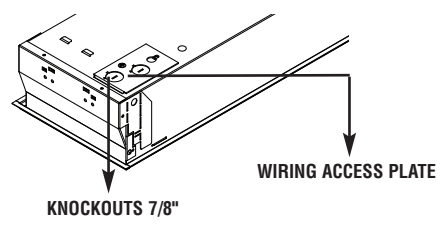

QUICK CONNECT HARNESS:
Factory-supplied quick connect harness reduces installed costs.

SPECIFICATIONS

CONSTRUCTION: Fixture assembly constructed using die-formed, 20-gauge, cold-rolled steel housing and ends. Lens and drivers are easily removable from below ceiling without the need for tools. The ballast compartment is also accessible from below ceiling by removing the reflector cover. Seismic brackets are integrated into the fixture assembly.

LUMINAIRE LENGTHS: Luminaires are available in 2', 4', and 8' section lengths and can be joined together with factory supplied plug together wiring harnesses.

REFLECTORS: Reflector is die-formed 25-gauge Aland 8516GP semi-specular aluminum with 94% high reflectance finish.

OPTICAL SYSTEM: Luminaires are standard with frosted lenses. All lenses are UV-stabilized and impact resistant virgin acrylic. Frosted lenses are 0.120" thick.

LIGHT ENGINE: HPW-1-LED 4' (4000K) delivers 3087 lumens at 37.5W. HPW-1-LED 4' (3500K) delivers 2807 lumens at 36.6W. HPW-1-LED 4' (3000K) delivers 2720

lumens at 36.8W. Light engine is made up of high performance mid-powered LEDs and is designed to distribute heat properly to maximize the life of the LED. LED color temperature: 3000K, 3500K or 4000K. CRI: 84 (4000K), 84 (3500K), 86 (3000K). R9: 16 (4000K), 15 (3500K), 30 (3000K).

DRIVER: High performance LED driver. Driver is fully accessible from below the ceiling. *120/277V. Power Factor = 90.6% (4000K), 91.1% (3500K), 94% (3000K). Contact factory for Emergency Battery backups. Total harmonic distortion : < 20%. Input current: 0.333 @ 120V.

*Driver can be wired as dimming or non-dimming. Dimming is compatible with 0-10v controls with a range of 100-20%.

ELECTRICAL: IC-Rated for all lampping. Optional Chicago Plenum available. Contact factory.

MOUNTING: Standard flange design works with most lay-in ceiling types. Integral pry out tabs secure luminaire to ceiling grid. Support to structure locations on

each corner. Consult local code for appropriate support to structure recommendations. Optional drywall kit available.

FEED: 18-gauge wire standard. Quick connect harnesses provided for row configurations.

FINISH: Housing assembly painted with Signal White powder coat finish.

WEIGHT: 2' - 14 lbs, 4' - 18 lbs, 8' - 30 lbs.

LABELS: Fixtures and electrical components are ETL certified to UL and C-UL standards. In accordance with NEC code 410.73 (G) this luminaire contains an internal driver disconnect.

WARRANTY: HPW-1-LED comes standard with a 10-year, worry-free warranty on all components.

winline surface linear 104/106 dry

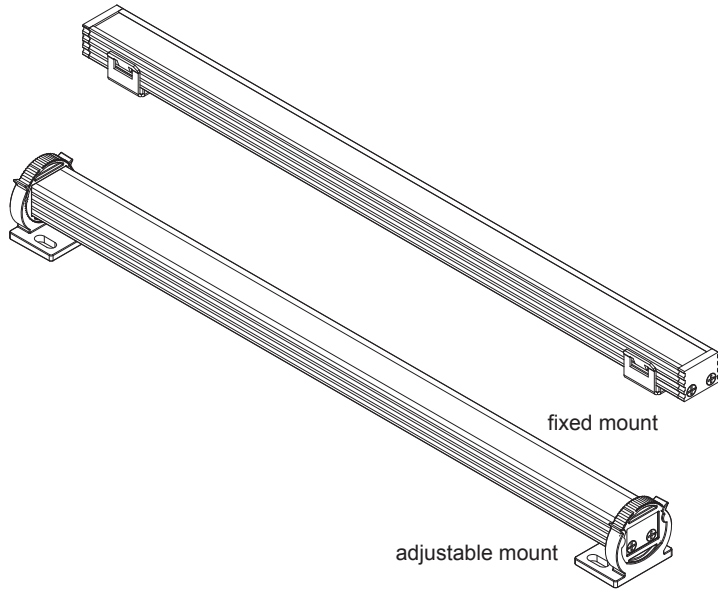

The **Winline 100 Series** are small scale linear LED luminaires and were designed to be the most powerful, reliable, and easiest to implement linear LED solution available. The model WSL104/106 is a high performance luminaire with robust construction suitable for interior illumination.

Beam Spreads: Model 104/106 is available in 30 and 100 degree beam spreads. See page 4 for photometric data.

Color & Light Output: The 100 Series utilizes Nichia 757 white LEDs in four standard color temperatures. Model 104/106 features (16) LEDs/ft.

100 Series	Model 104		Model 106	
Color Temperature	lm/ft	W/ft	lm/ft	W/ft
ANSI-2700K White	140	3.2	281	6.2
ANSI-3000K White	166	3.2	331	6.2
ANSI-3500K White	172	3.2	344	6.2
ANSI-4000K White	182	3.2	368	6.2

Results based test LTL 22006
100° beam spread

Note:
LM79 Tests- see page 4.

Power: The Winline 100 series operates on 24VAC using magnetic transformers. A wide range of remote transformers are available in 120V and 277V primary.

Dimming: Used with remote mounted 24VAC magnetic transformers which can be dimmed with commonly available low voltage magnetic dimming equipment.

Mounting & Adjusting: Both fixed and adjustable mounts allow the 100 Series to be used almost anywhere. The installer locates and fastens the mount clip, runs power feed lines, connects the fixture's wire leads to the feed lines and snaps the fixture in place. The low profile fixed mount is only 1/8" high and the adjustable mount allows for 300 degree rotation around the centerline of the fixture. See pages 2-3 for more mounting and adjustment information.

Operating Temperature: Minimum and maximum ambient air temperatures around this luminaire shall not exceed -22°F to 122°F (-30°C to 50°C). Any application of this product should also take into consideration air flow and ventilation to ensure performance and reliability.

Winona Lighting reserves the right to make design changes without prior notice.

Refer to the Winline Application Guide (www.winonalighting.com/products/commercial-led-lighting/led_linear/104-106) for more product detail.

Weight:

- 12" - .31 lbs 36" - .84 lbs
- 18" - .44 lbs 42" - .98 lbs
- 24" - .58 lbs 48" - 1.11 lbs
- 30" - .71 lbs



Listing: Winline 104/106 is ETL listed for dry location. Complies with UL Standard 2108



Winline Surface Linear - WSL	WSL
	series

model 104 dry - 104 model 106 dry - 106	
	model

Total Run Length in Feet offered in 6" increments starting at 12" <i>ex. 54 FT= 54 foot run</i> or Preconfigured Run Length Code <i>see page 5</i> or To Be Determined <i>TBD when run length unknown</i>	
	run length code

30° - 30 100° - 100	
	beam spread

ANSI-binned 2700K - 27K ANSI-binned 3000K - 30K ANSI-binned 3500K - 35K ANSI-binned 4000K - 40K	
	LED code

non-dimming 24 volt AC - ND24V dimming 24 volt AC - DM24V	
	voltage

fixed - F adjustable - A	
	mount

natural (type III) anodized aluminum - NAA semi gloss black paint - SGB semi gloss white paint - SGW custom paint finish - CPF	
	finish

none - X	X
	options

standard - STD modified - MOD	
	special

Describe Modification:

The Winline 100 Series is available in lengths up to 48" in 6" increments starting at 12".

Mounting

The 100 Series can be mounted end-to-end with no shadows between units. Two unique mounting methods allow for flexible, quick and easy installation. Both mounts can be installed in any position.

Fixed Mount

Nominal Length	Installed Length	Installed Length
12"	12.39"	314.71mm
18"	18.39"	467.12mm
24"	24.39"	619.51mm
30"	30.39"	771.91mm
36"	36.39"	924.31mm
42"	42.39"	1076.71mm
48"	48.39"	1229.12mm

Fixed Mount

Luminaires can be mounted as close as .125" min.(3.18mm)

30° Fixed Mount

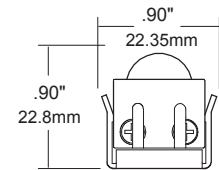

100° Fixed Mount

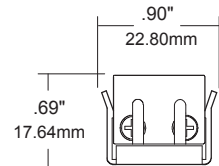

Adjustable Mount

Nominal Length	Installed Length	Installed Length
12"	12.52"	318.01mm
18"	18.52"	470.41mm
24"	24.52"	622.81mm
30"	30.52"	776.21mm
36"	36.52"	927.61mm
42"	42.52"	1080.01mm
48"	48.52"	1232.41mm

Adjustable Mount

Luminaires can be mounted as close as .125" min.(3.18mm)

30° Adjustable Mount

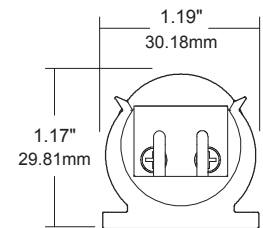

100° Adjustable Mount

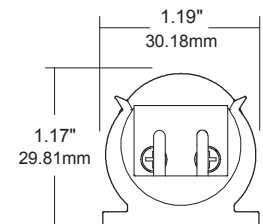

The 100 Series Adjustable Mount allows for 300 degree continuous rotation.

The WINLINE 100 Series is to be powered by 24VAC only. **Do not connect directly to line voltage under any circumstance.** Connection to line voltage will permanently damage internal components and void manufacturer's warranty.

POWER REQUIREMENTS

The WINLINE 100 series must be powered by a magnetic transformer. **Do not use electronic transformers.** Choose a transformer with adequate capacity. Total load should not exceed 80% of the rated output of the transformer at 24VAC.

Model	Power Consumption	Maximum Run Length
104	3.2 w/ft	54 ft
106	6.2 w/ft	38 ft

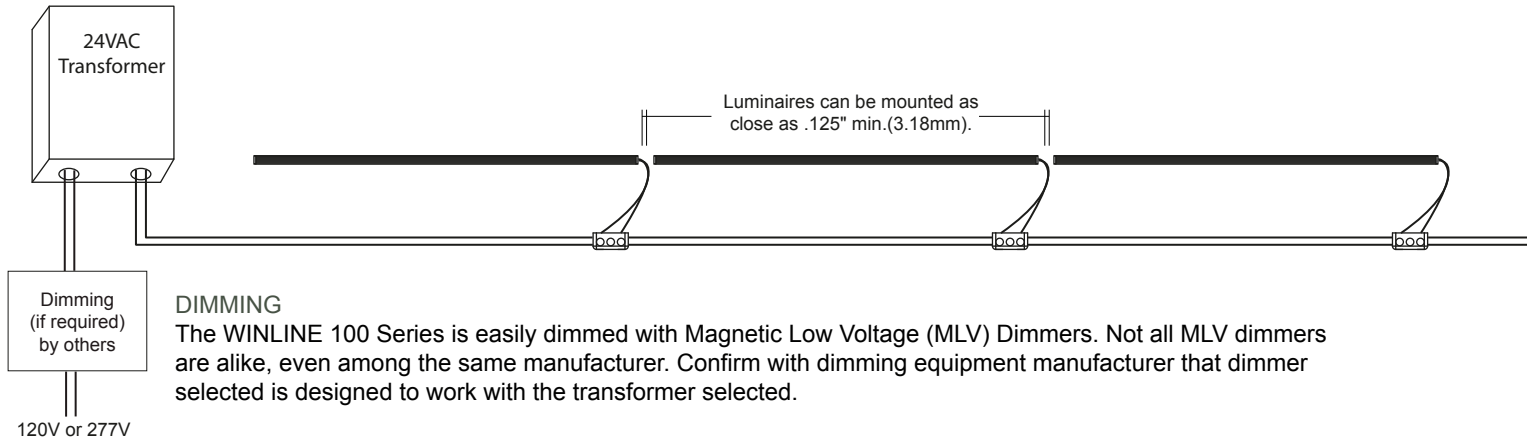

Fixed Mount

**See full installation instructions online*

Step 1 Layout, mark, and attach mount clips.

Step 2 Lay in power feed wires and make electrical connections using supplied connectors.

Step 3 Snap into place and aim luminaire as required.

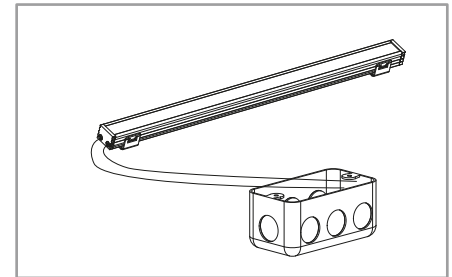
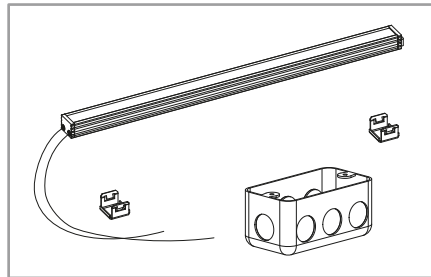

Adjustable Mount

**See full installation instructions online*

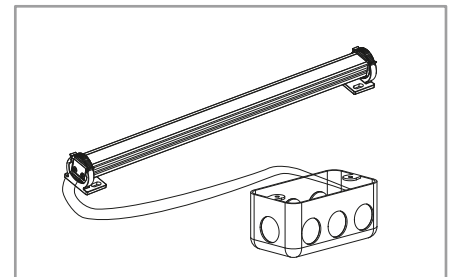
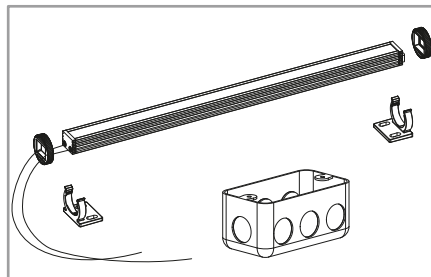
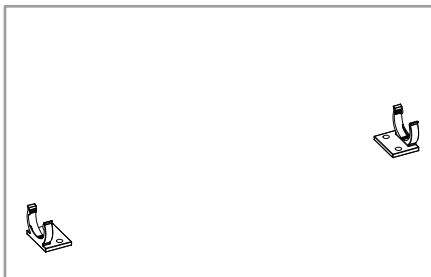

REMOTE MOUNTING CONSIDERATIONS

The WINLINE 100 Series is powered from remote-mounted transformers. The maximum remote distance of the transformer is dependent on many factors including total LED load, wire size, distance from the transformer to the first fixture in each run, and starting voltage at the transformer.

The installer is to ensure that 24VAC is present at the beginning of the run. By using a combination of large-gauge wire and adjusting the output voltage of the transformer, the installer can compensate for voltage drop over long remote distances. Use of #12 wire is recommended.

winline surface linear 104/106 dry

photometrics

30°

Test Report: 22005 Catalog Number: WSL-106-48-30-30K
 Description: 96 Nichia 757 3000K LEDs / 48" Winline 106 Dry Luminaire / Extruded Aluminum Housing / Acrylic Lens

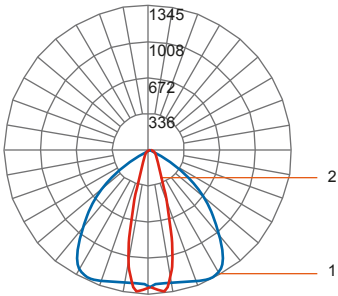

Maximum Candela = 1345 Located At Horizontal Angle = 0, Vertical Angle = 5
 #1 - Vertical Plane Through Horizontal Angles (0-180) (Through Max. Cd.)
 #2 - Vertical Plane Through Horizontal Angles (90-270)

LM79 Data - Based on WSL106/30°/30K Test Results

Color Temperature	Multiplier	Total Lumens	Lamp Watts	Lumens per Watt	CRI	Power Factor
ANSI-binned 2700K	0.85	1126	25	45.0	84.3	.77
ANSI-binned 3000K	1.00	1324	25	52.9	82.9	.77
ANSI-binned 3500K	1.03	1376	25	55.0	83.0	.77
ANSI-binned 4000K	1.10	1469	25	58.7	87.0	.77

Zonal Lumen Summary		Zone	Lumens	%Fixture
3000K		0-30	671	50.7
		0-40	880	66.5
		0-60	1142	86.3
		0-90	1287	97.2
Total Luminaire		0-180	1324	100.0

Candlepower Distribution 3000K

Angle	Horizontal Plane				
	0	22.5	45	67.5	90
0	1290	1290	1290	1290	1290
5	1258	1298	1331	1340	1340
10	1267	1325	1298	1195	1148
15	1289	1302	1057	831	738
20	1320	1154	686	403	337
25	1345	907	364	224	198
30	1317	610	226	154	139
35	1200	390	160	118	108
40	1019	273	120	95	91
45	818	202	94	79	77
50	604	152	73	65	64
55	408	114	58	54	54
60	260	84	46	47	49
65	159	61	38	46	52
70	93	44	34	54	57
75	51	32	38	51	52
80	25	24	38	50	54
85	8	21	33	46	48
90	1	17	28	39	38

100°

Test Report: 22006 Catalog Number: WSL-106-48-100-30K
 Description: 96 Nichia 757 3000K LEDs / 48" Winline 106 Dry Luminaire / Extruded Aluminum Housing / Acrylic Lens

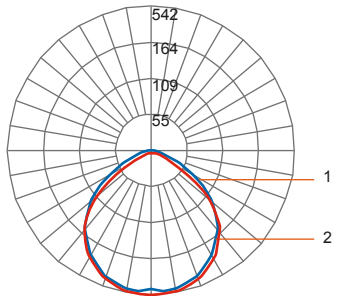

Maximum Candela = 542 Located At Horizontal Angle = 0, Vertical Angle = 5
 #1 - Vertical Plane Through Horizontal Angles (0-180)
 #2 - Vertical Plane Through Horizontal Angles (90-270)

LM79 Data - Based on WSL106/100°/30K Test Results

Color Temperature	Multiplier	Total Lumens	Lamp Watts	Lumens per Watt	CRI	Power Factor
ANSI-binned 2700K	0.85	1105	25	44.2	84.4	.77
ANSI-binned 3000K	1.00	1300	25	52.0	83.0	.77
ANSI-binned 3500K	1.03	1352	25	54.0	83.1	.77
ANSI-binned 4000K	1.10	1444	25	57.7	87.1	.77

Zonal Lumen Summary		Zone	Lumens	%Fixture
3000K		0-30	423	32.5
		0-40	693	53.3
		0-60	1142	87.9
		0-90	1299	99.9
Total Luminaire		0-180	1300	100.0

Candlepower Distribution 3000K

Angle	Horizontal Plane				
	0	22.5	45	67.5	90
0	538	538	538	538	538
5	527	534	540	541	538
10	521	529	535	536	534
15	511	520	526	526	524
20	497	506	510	510	508
25	477	486	490	490	490
30	453	463	465	468	466
35	423	433	436	436	434
40	388	398	399	390	381
45	350	358	353	324	310
50	306	314	292	245	220
55	259	264	220	156	130
60	212	207	147	93	86
65	163	146	82	66	64
70	111	92	51	47	48
75	62	48	32	32	34
80	26	22	17	19	20
85	6	7	8	10	10
90	0	1	1	0	0

Patent Pending

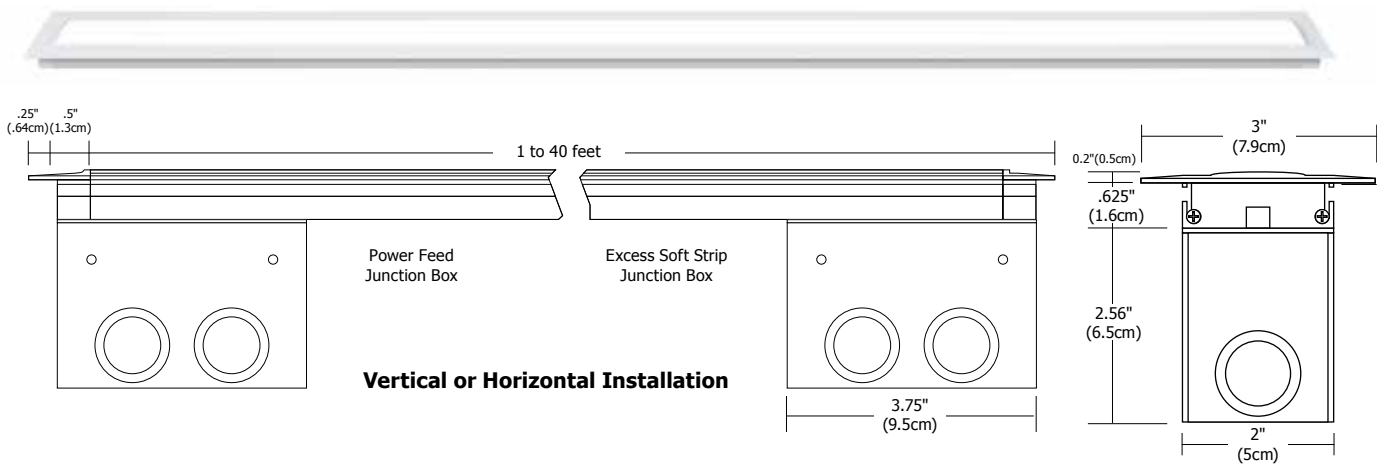

Description: TruLine 1.6 creates a clean line of glare-free general illumination within drywall. The 24VDC linear LED system features a shallow, 5/8" deep plaster-in aluminum extrusion no thicker than drywall that houses two rows of high CRI, commercial grade white LED Soft Strip. Its 1.6" wide diffuser lens projects a clean line of light without LED dots. System mounts to studs without joist modification. TruLine is sold in 1 foot increments up to 40 feet (5W) or 20ft (10W) and may be field-cut to any length. Coordinate installation with electrician and drywall contractors. Fixture includes a 5 year warranty. Patent pending.

Design Notes: TruLine runs in a straight line. The LED strip bends along the LED plane, allowing runs to continue from a wall onto a ceiling. Intersecting runs on the same wall require two separate TruLine systems.

Applications: Indoor Only—General illumination and architectural lighting for offices, hospitality, retail, residences, libraries, closets, hallways, bath/vanity.

Lamp: Two rows of white LEDs (2400K, 80+CRI; 2700K or 3000K, 85+CRI). LEDs consume 5 (2x2.5) or 10 watts per ft, delivering 40 lumens per system watt, 243 lumens per ft (5WDC) and 486 lumens per ft (10WDC)

Average Lamp Life: 50,000 hours

Power Supply: Class 2, 120-277VAC input.

PSB-96W-010-24VDC: 96W output; 5WDC Max of 20ft run(s), 10WDC Max of 10ft run(s)

PSB-2x96W-010-24VDC: 24VDC 2X96W output; 5WDC Max of 20ft run(s)/circuit, 10WDC Max of 10ft run(s)/circuit

Dimming: Lightolier: Sunrise, ZP600FAM120; Leviton: IP710-DL; Lutron: Radio Ra2 with Grafik Eye, RRD-10ND and GRX-TVI; Grafik Eye QS with Grafik Eye, QSGRJ-XP and GRX-TVI; Diva with Grafik Eye, DVTV and PP20; Nova T with Grafik Eye, NTFTV and PP20

Included Components: TruLine 1.6 channels, end caps, LED Soft Strip, TL 1.6 special Junction Boxes (quantity 2) and all mounting hardware. See page 2 of spec sheet for additional details.

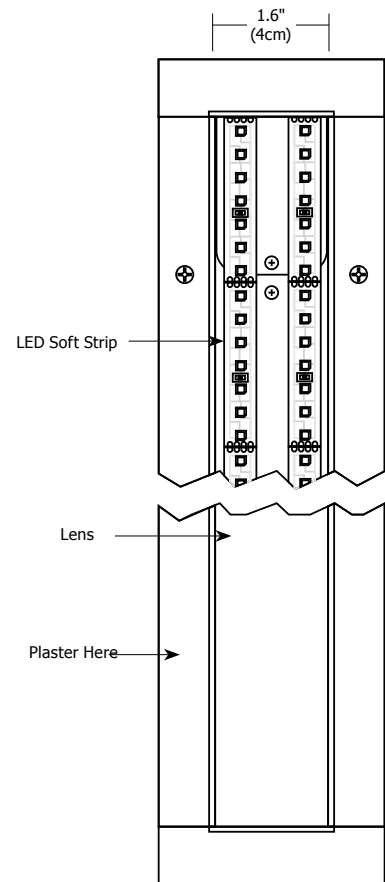

TRULINE 1.6, 24VDC ORDERING CODE

System	Wattage	Length in Feet	Color Temperature	Finish	
TL1.6	- 5WDC	- 40FT	- 27K	- WH	
TL1.6	TruLine 1.6" Wide	5WDC - 5 Watts/Foot 10WDC - 10 Watts/Foot	1-40 Feet* *10WDC Up to 20ft	24K 2,400K Amber White 27K - 2,700K Very Warm White 30K - 3,000K Warm White	WH - White

COMPANY	FIXTURE TYPE	DATE
PROJECT	APPROVED BY	

Product specification subject to change without notification. REV. 02.13.14

A Division of PureEdge Lighting 1718 W. Fullerton Chicago, IL 60614 • Ph: 773.770.1196 • Fax: 773.883.6128 • www.purelighting.com



Patent Pending

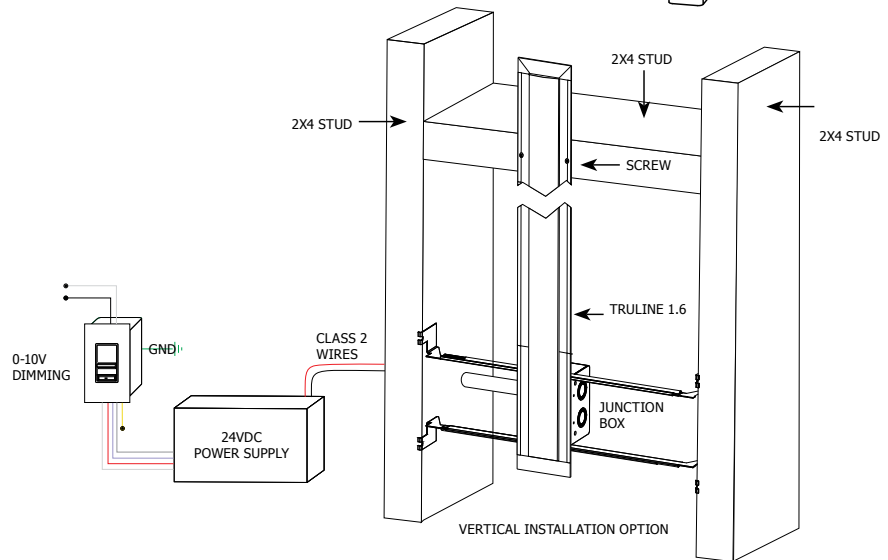
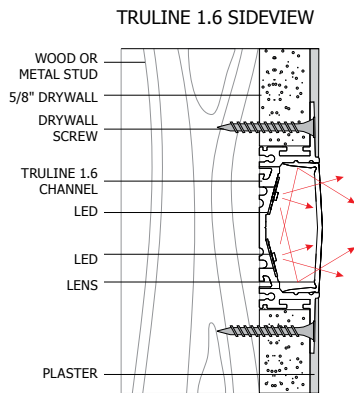
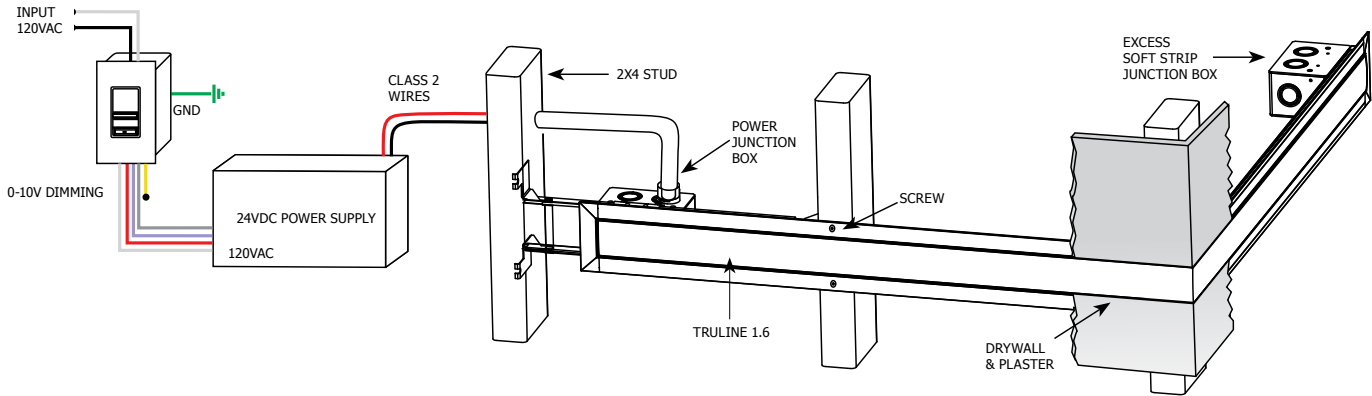

INCLUDED COMPONENTS



TRULINE 1.6 JUNCTION BOX

Two TruLine 1.6 Junction Boxes included: One for use as a power feed junction box and the other for housing excess Soft Strip at the end of run.

Slim profile junction box mounts behind drywall. Low voltage DC wires from remote power supply connect to LED wires. Junction box opening covered by TruLine channel for a clean, safe connection.

For rough-in installation, junction boxes can be ordered in advance. Ordering Code: TL1.6-JBOX



LED SOFT STRIP

Two rows of white LEDs (2400K, 80+CRI; 2700K or 3000K, 85+CRI). LEDs consume 5 (2x2.5) or 10 watts per ft, delivering 243 lumens per ft and 40 lumens per system watt.



END CAPS

For a finished look and to complete the installation, use end caps at the end of runs. End caps house the power cable from the LED Soft Strip.

COMPANY		FIXTURE TYPE		DATE	
PROJECT		APPROVED BY			

Product specification subject to change without notification. REV. 02.13.14

A Division of PureEdge Lighting 1718 W. Fullerton Chicago, IL 60614 • Ph: 773.770.1196 • Fax: 773.883.6128 • www.purelighting.com



Patent Pending

Application: 0-10V dimming for Truline 1.6

Power Supply: Class 2, 120-277VAC input. PSB-96W-010-24VDC: 24VDC 96W output
 PSB-2x96W-010-24VDC: 24VDC 192W output

Dimming: Dimmable with 0-10V dimmer using power supply above. Lightolier: Sunrise, ZP600FAM120; Leviton: IP710-DL
 Lutron: Radio Ra2 with Grafik Eye, RRD-10ND and GRX-TVI; Grafik Eye QS with Grafik Eye, QSGRJ-XP and GRX-TVI;
 Diva with Grafik Eye, DVTV and PP20; Nova T with Grafik Eye, NTFTV and PP20

96W, 24VDC LOW VOLTAGE WIRE SIZE CHART: 3% VOLTAGE DROP

WIRE LENGTH (FT)	UP TO 33FT	34FT-52FT	53FT-86FT	87FT-130FT
WIRE SIZE	14 AWG	12 AWG	10 AWG	8 AWG
VOLTAGE AT END OF WIRE	23.28VDC	23.29VDC	23.28VDC	23.28VDC

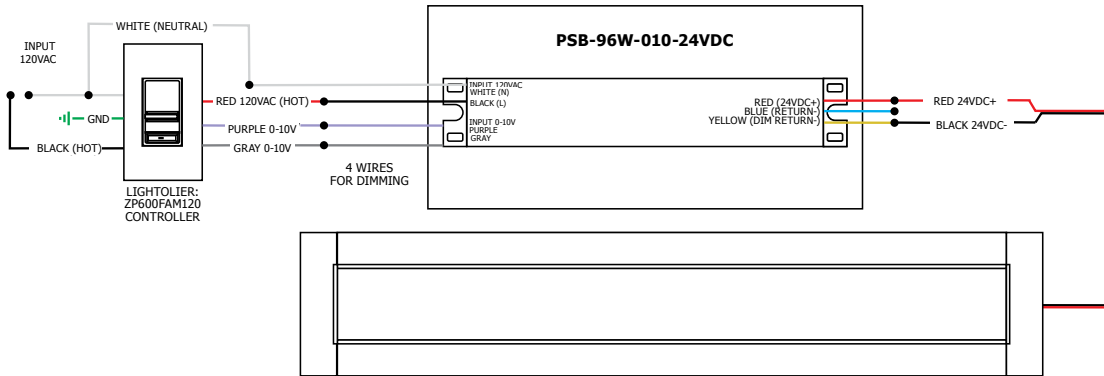

MOUNTING HARDWARE (INCLUDED)

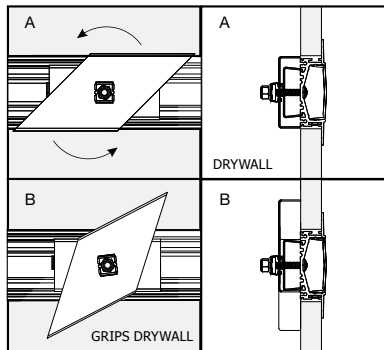

COMPANY		FIXTURE TYPE		DATE	
PROJECT		APPROVED BY			

Product specification subject to change without notification. REV. 02.13.14

ACTUAL WATTAGE PER FOOT - 5 WATTS

LENGTH IN FEET	TOTAL WATTAGE
1	5
2	10
3	16
4	20
5	26
6	30
7	34
8	40
9	44
10	48

LENGTH IN FEET	TOTAL WATTAGE
11	54
12	58
13	64
14	68
15	74
16	78
17	82
18	88
19	92
20	96

LENGTH IN FEET	TOTAL WATTAGE
21	2 x 51W
22	2 x 54W
23	2 x 56W
24	2 x 58W
25	2 x 61W
26	2 x 63W
27	2 x 66W
28	2 x 68W
29	2 x 70W
30	2 x 72W

LENGTH IN FEET	TOTAL WATTAGE
31	2 x 75W
32	2 x 78W
33	2 x 80W
34	2 x 82W
35	2 x 85W
36	2 x 87W
37	2 x 90W
38	2 x 92W
39	2 x 94W
40	2 x 96W

ACTUAL WATTAGE PER FOOT - 10 WATTS

LENGTH IN FEET	TOTAL WATTAGE
1	10
2	20
3	32
4	40
5	48
6	60
7	68
8	80
9	88
10	96

LENGTH IN FEET	TOTAL WATTAGE
11	2 x 54
12	2 x 58
13	2 x 64
14	2 x 68
15	2 x 72
16	2 x 78
17	2 x 82
18	2 x 88
19	2 x 92
20	2 x 96

A Division of PureEdge Lighting 1718 W. Fullerton Chicago, IL 60614 • Ph: 773.770.1196 • Fax: 773.883.6128 • www.purelighting.com

COMPANY		FIXTURE TYPE		DATE	
PROJECT		APPROVED BY			



Project:

DLED-5400 Square Series Specification Sheet

LED 50,000 Hour Dimmable Light Channel with Angled LED Light Source - 50 Lumens per Foot - 2.5 Watts per Foot - CRI 70

Date:

Type:

Cat. No. DLED-5400 - _____ - _____ - _____ - _____ - _____ - _____ - _____

Fixture Description: A continuous LED dimmable light strip mounted inside a square clear or frosted acrylic channel (maximum 12 foot run per feed) that offers a warm, soft, even glow at a huge savings over incandescent, halogen, or fluorescent. Runs cooler than incandescent or halogen, and contains no harmful gasses. 50,000 hour lamp life saves on maintenance and re-lamping costs.

Construction: 20 LED diodes per foot wired into rigid LED channel with jumper wire and feed wire pre-wired and attached. For lengths over 69", two strips are connected by a 1" flex wire to create a single length of up to 138" max.

Electrical: 24 Volt AC. 2.5 Watts per foot. 50 lumens per foot. Dimmable.

Mounting: Mounts into coves or other surfaces with clips and/or double stick tape.

Applications:

- Coves • Light Pockets • Accent Lighting
- Cabinet Lighting • Undercabinet Lighting
- Reveal Molding

Note: Actual length of tube is 1/2" longer than specified length. Ex: DLED-5300-46 is actually 46-1/2" long.

IMPORTANT: LED strips are to be fed from UL Listed Class II magnetic transformers.

NOTE: Dimmers used must be approved for magnetic loads and use direct current or voltage regulation, such as Lutron Diva Series. Dimmers that use phase forward dimming technology must have a neutral. Check with factory for compatibility.

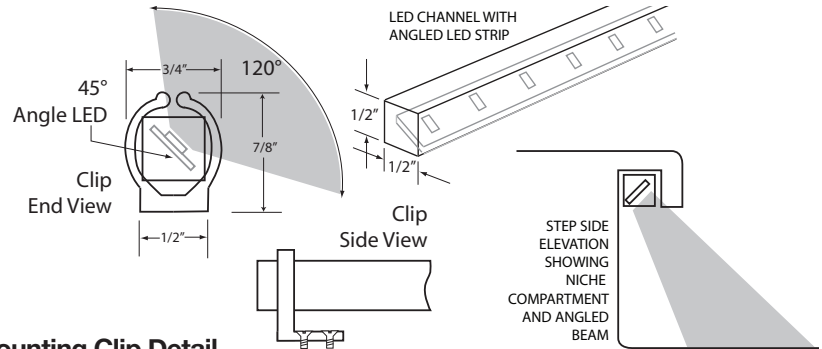

Mounting Clip Detail

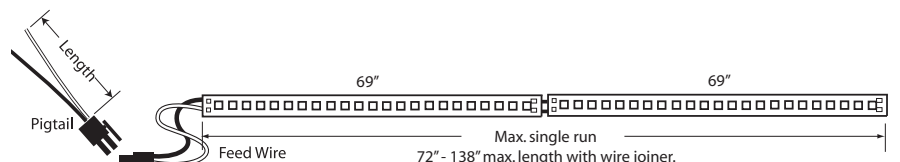
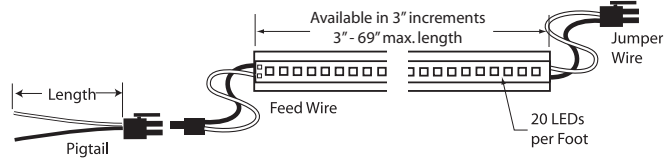

2 separate lengths joined with 1" flex wire for LED Strips from 72" - 138".
NOTE: Connectors are not to be used in damp and wet location. Use appropriate wire nut connectors.
 All dimensions are plus 1-1/4" length.

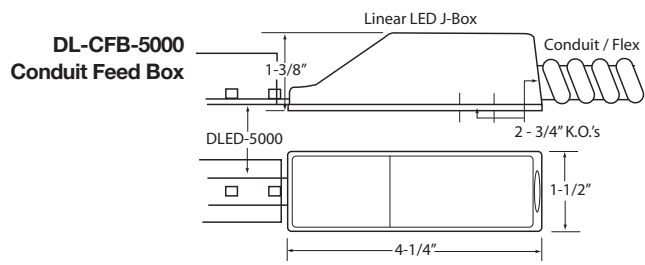

Voltage:	24 Volts AC
Watts:	2.5 Watts per foot
Beam Spread:	120°
Max. Run:	12 feet
Max. Single Length:	69"
Mounting:	Clips

Secondary Wire Specification	
Max. Load:	50 Watts
Max. Distance:	50 Feet
	16 AWG 2/C Type CM-CL2
	ETL-CM CL3
	Standard copper conductor

Model No.	Acrylic Tube with LED Strip Length (+1/2")	Acrylic Material	Wire Format	Feed Wire Length	Jumper Wire Length	Pigtail Length**	Color Temp.
DLED-5400	3", 6", 9", 12", 15", 18", 21", 24", 27", 30", 33", 36", 39", 42", 45", 48", 51", 54", 57", 60", 63", 66", 69"	CL Clear	EW End Wire (Std.)	1.5", 3", 6", 12", 18", 30", Custom	None* (0), 1.5", 3", 6", 12", 18", 30", Custom	0", 3", 12", 36", Custom	2700K 3000K 6500K
	See NOTE for LED Lengths Over 69"	FR Frosted	SW Side Wire (Custom)				
	72", 75", 78", 81", 84", 87", 90", 93", 96", 99", 102", 105", 108", 111", 117", 120", 123", 126", 129", 132", 135", 138"						

NOTE: All LED lengths 72" - 138" are made up of 2 separate units joined together by a 1" flex wire.
DIMENSION ALLOWANCE: ALL DIMENSIONS LISTED ARE PLUS 1/2". TUBE IS 1/2" LONGER THAN SPECIFIED LED LENGTH.
FOR CURVILINEAR APPLICATIONS - SPECIFY .75" JUMPER WIRE LENGTH

*NOTE: You can specify "0" for no jumper wire on the end.
 ** NOTE: 1 pigtail per run (specify 3", 12", 36", or Custom).

Ordering Example: **DLED-5400 - 45" - CL - SW- F6" - J3" - P3" - 2700**



©2012 Dreamscape Lighting Mfg., Inc.
 5521 W. Washington Blvd. • Los Angeles, CA 90016
 Phone: 323-933-5760 • FAX: 323-933-3607
 info@dreamscapelighting.com • www.dreamscapelighting.com
 Specifications subject to change without notice



DESCRIPTION

SNLED Lensed is a narrow LED lensed striplight series. This high quality luminaire is dedicated to the latest solid state lighting and electronic driver technology for optimal performance and energy efficiency. This Lensed product is available with three different lens types.

The small size of the SNLED makes it an ideal choice for size restricted architectural applications. The SNLED Series can be the illumination solution in commercial, industrial, retail and residential applications. Fixtures can be used in storage/utility areas, coves, display cases, shops, task and general area lighting.

SPECIFICATION FEATURES

Construction

Channel is die formed cold rolled steel with numerous KOs for ease of installation. Groove for Tong Hanger. End plate quickly converts to snap-in channel connector for continuous row alignment. Channel/wireway cover secured with sheet metal screws.

Controls

Equipped standard with a 0-10V continuous dimming driver that works with any standard 0-10V control/dimmer. Dimming range is 10% to 100%; varies by control device. Combine with energy-saving products like occupancy sensors, day lighting controls, and lighting relay panels from Cooper Controls (www.coopercontrol.com) to maximize energy savings.

Electrical

Long-Life LED system coupled with electronic (120-277V) driver to deliver optimal lighting performance. LED's available in 3500k, 4000k, or 5000k with a CRI ≥ 85 . Other color temperatures are available. Projected life is 72,000 hours at 70% lumen output. This driver is 0-10V dimming standard.

Finish

Multistage iron phosphate pretreatment ensures maximum bonding and rust inhibitor. High reflective paint after fabrication, baked white enamel finish is standard.

Channel/Wireway Cover

Die formed heavy gauge steel. Tight fit for ease of maintenance.

Catalog #		Type
Project		
Comments		Date
Prepared by		

Shielding

Offers three different lensed optical distributions.

Installation

Fixture may be surface, pendant, or stem mounted. See accessories below in ordering information.

Compliance

Components are CSA recognized. Indoor luminaires are CSA listed for 35°C ambient environments, RoHS compliant, and comply with IESNA LM-79. LEDs comply with LM-80 standards. DesignLights™ Consortium Qualified (both lumen versions). Refer to www.designlights.org Qualified Products under Family Models for details.

Warranty

Five-year warranty.



SNLED LENSED LED

Lensed LED Striplight

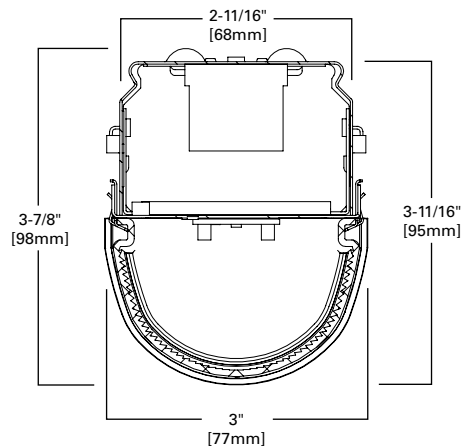

PHOTOMETRICS

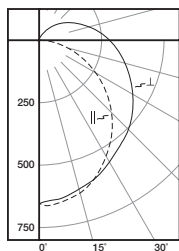

SNLED-LD1-52-LW-UNV-L835-CD1-U
 Electronic Driver
 3500K LEDs
 Spacing criterion:
 (||) 1.2 x mounting height,
 (⊥) 1.3 x mounting height
 Test Report:
 P32263-R2

Candlepower

Angle	Along	45°	Across ⊥
0	1199	1199	1199
5	1200	1190	1190
10	1190	1179	1181
15	1159	1152	1162
20	1115	1119	1133
25	1052	1072	1101
30	990	1029	1067
35	915	978	1031
40	832	922	996
45	743	866	958
50	654	805	911
55	559	743	867
60	471	684	818
65	375	625	765
70	284	565	716
75	198	508	663
80	120	454	611
85	57	402	562
90	10	355	514

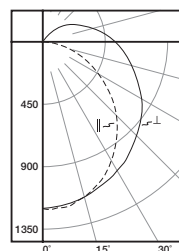

SNLED-LD1-28-LW-UNV-L840-CD1-U
 Electronic Driver
 4000K LEDs
 Spacing criterion:
 (||) 1.2 x mounting height,
 (⊥) 1.3 x mounting height
 Test Report:
 P23279-R2

Candlepower

Angle	Along	45°	Across ⊥
0	654	654	654
5	661	652	646
10	651	641	635
15	633	626	622
20	609	605	605
25	578	579	586
30	541	551	567
35	500	522	547
40	455	491	527
45	408	459	505
50	358	426	483
55	308	393	460
60	257	361	435
65	206	330	410
70	156	299	384
75	108	269	357
80	65	241	330
85	30	214	303
90	1	188	276

Coefficients of Utilization

rc	Effective floor cavity reflectance																	
	80%			70%			50%			30%			10%			0%		
rw	70	50	30	10	70	50	30	10	50	30	10	50	30	10	50	30	10	0
RCR																		
0	115	115	115	115	110	110	110	110	102	102	102	94	94	94	87	87	87	83
1	102	96	91	86	97	92	87	83	84	81	77	78	75	72	71	69	67	63
2	92	82	74	68	87	79	72	65	72	66	61	66	62	57	61	57	54	50
3	83	71	62	55	79	68	60	53	63	56	50	58	52	47	53	48	44	41
4	75	63	53	46	72	60	51	45	55	48	42	51	45	40	47	42	38	35
5	69	56	46	39	66	53	45	38	49	42	36	46	39	34	42	37	32	30
6	64	50	40	34	61	48	39	33	44	37	31	41	35	30	38	32	28	26
7	59	45	36	29	56	43	35	29	40	33	27	37	31	26	35	29	25	22
8	55	41	32	26	52	39	31	26	37	29	24	34	28	23	32	26	22	20
9	51	37	29	23	49	36	28	23	34	27	22	31	25	21	29	24	20	18
10	48	34	26	21	46	33	26	21	31	24	20	29	23	19	27	22	18	16

Coefficients of Utilization

rc	Effective floor cavity reflectance																	
	80%			70%			50%			30%			10%			0%		
rw	70	50	30	10	70	50	30	10	50	30	10	50	30	10	50	30	10	0
RCR																		
0	115	115	115	115	110	110	110	110	102	102	102	94	94	94	86	86	86	83
1	102	96	90	86	97	92	87	83	84	80	77	77	74	71	71	69	66	63
2	92	82	74	68	87	79	71	65	72	66	61	66	61	57	61	57	54	50
3	83	71	62	55	79	68	60	53	63	56	50	58	52	47	53	48	44	41
4	75	63	53	46	72	60	51	45	55	48	42	51	45	40	47	42	37	35
5	69	56	46	39	66	53	45	38	49	42	36	45	39	34	42	37	32	30
6	64	50	40	34	61	48	39	33	44	37	31	41	35	30	38	32	28	26
7	59	45	36	30	56	43	35	29	40	33	27	37	31	26	35	29	25	22
8	55	41	32	26	52	39	31	26	37	30	24	34	28	23	32	26	22	20
9	51	37	29	23	49	36	28	23	34	27	22	31	25	21	29	24	20	18
10	48	34	26	21	46	33	26	21	31	24	20	29	23	19	27	22	18	16

Zonal Lumen Summary

Zone	Lumens	%Fixture
0-30	939	17.9
0-40	1551	29.6
0-60	2869	54.7
0-90	4362	83.2
0-180	5245	100.0

Zonal Lumen Summary

Zone	Lumens	%Fixture
0-30	505	18.0
0-40	831	29.6
0-60	1530	54.5
0-90	2326	82.8
0-180	2326	100.0

MOUNTING DATA

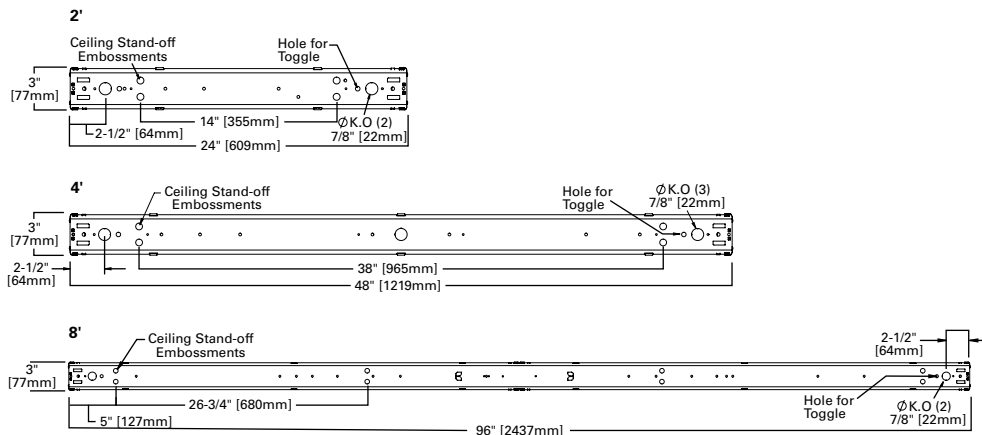

WATTAGE

Product Type	Product Configurations	Length	Lumen Package	Wattage	LPW
Lensed - Clear	2SNLED-LD1-23-LC-UNV-L8XX-CD1-U	2 ft.	2300	23.11	100
Lensed - Clear	SNLED-LD1-31-LC-UNV-L8XX-CD1-U	4 ft.	3100	28.32	109.5
Lensed - Clear	SNLED-LD1-49-LC-UNV-L8XX-CD1-U	4 ft.	4900	49.6	98.8
Lensed - Clear	SNLED-LD1-58-LC-UNV-L8XX-CD1-U	4 ft.	5800	53.15	109
Lensed - Clear	8TSNLED-LD1-67-LC-UNV-L8XX-CD1-U	8 ft.	6700	64.49	106
Lensed - Clear	8TSNLED-LD1-94-LC-UNV-L8XX-CD2-U	8 ft.	9400	96.45	97
Lensed - Clear	8TSNLED-LD1-115-LC-UNV-L8XX-CD2-U	8 ft.	11500	107.84	106.7
Lensed - Narrow	2SNLED-LD1-23-LN-UNV-L8XX-CD1-U	2 ft.	2300	23.06	100
Lensed - Narrow	SNLED-LD1-30-LN-UNV-L8XX-CD1-U	4 ft.	3000	28.32	106
Lensed - Narrow	SNLED-LD1-48-LN-UNV-L8XX-CD1-U	4 ft.	4800	49.6	97
Lensed - Narrow	SNLED-LD1-57-LN-UNV-L8XX-CD1-U	4 ft.	5700	53.15	107
Lensed - Narrow	8TSNLED-LD1-64-LN-UNV-L8XX-CD1-U	8 ft.	6400	64.49	99
Lensed - Narrow	8TSNLED-LD1-90-LN-UNV-L8XX-CD2-U	8 ft.	9000	96.45	93
Lensed - Narrow	8TSNLED-LD1-109-LN-UNV-L8XX-CD2-U	8 ft.	10900	107.84	101
Lensed - Wide	2SNLED-LD1-21-LW-UNV-L8XX-CD1-U	2 ft.	2100	23.04	91
Lensed - Wide	SNLED-LD1-28-LW-UNV-L8XX-CD1-U	4 ft.	2800	28.31	99
Lensed - Wide	SNLED-LD1-44-LW-UNV-L8XX-CD1-U	4 ft.	4400	49.78	88.4
Lensed - Wide	SNLED-LD1-52-LW-UNV-L8XX-CD1-U	4 ft.	5200	53.13	98
Lensed - Wide	8TSNLED-LD1-60-LW-UNV-L8XX-CD1-U	8 ft.	6000	64.49	93
Lensed - Wide	8TSNLED-LD1-85-LW-UNV-L8XX-CD2-U	8 ft.	8500	96.45	88
Lensed - Wide	8TSNLED-LD1-99-LW-UNV-L8XX-CD2-U	8 ft.	9900	107.84	92

ORDERING INFORMATION

SAMPLE NUMBER: SNLED-LD1-47-LN-UNV-L840-CD1-U

<p>2=2' Length [Blank]=4' Length 8T=8' Length</p>	<p>Voltage UNV=Universal Voltage 120-277 347=347V⁽⁴⁾ 480=480V⁽⁴⁾</p>	<p>Driver Type CD=0-10V Dimming Driver SD=Step-dim (Bi Level) 5LTD=Fifth Light (DALI) Driver⁽⁶⁾</p>	<p>Packaging U=Unit Pack</p>
<p>Series SNLED=Commercial LED Striplight</p>	<p>Optic LC=Lensed Clear LN=Lensed Narrow LW=Lensed Wide</p>	<p>Number of Drivers 1=1 Driver 2=2 Drivers</p>	
<p>Lamp Type LD1=LED 1.0</p>			

LED Lumens Output⁽²⁾

Lensed - Clear	Lensed - Narrow	Lensed - Wide
23=2300 ⁽¹⁾	23=2300 ⁽¹⁾	21=2100 ⁽¹⁾
31=3100	30=3000	28=2800
49=4900	48=4800	44=4400
58=5800	57=5700	52=5200
67=6700	64=6400	60=6000
94=9400 ⁽³⁾	90=9000 ⁽³⁾	85=8500 ⁽³⁾
115=11500 ⁽³⁾	109=10900 ⁽³⁾	99=9900 ⁽³⁾

NOTES: ⁽¹⁾ 2 ft. only. ⁽²⁾ Nominal lumen values. ⁽³⁾ Two driver required. ⁽⁴⁾ 4 ft. and 8 ft. only. ⁽⁵⁾ Dimmable. ⁽⁶⁾ For a complete listing of Fifth Light Technology products and other solutions from Cooper Controls, visit www.coopercontrol.com. ⁽⁷⁾ EL options are integral. ⁽⁸⁾ Must specify voltage (120V or 277V) when selecting EL option. ⁽⁹⁾ For delivered lumens, take lumens per watt of desired fixture and multiply by 10 watts (100 lp/W x 10 = 1000 lumens delivered).

Specifications & dimensions subject to change without notice. Consult your Cooper Lighting Representative for availability and ordering information.

Options

Emergency
EL=Emergency Installed, 700 Lumens ^{(7), (8)}
EL14=Emergency Installed, 1400 Lumens ^{(7), (8)}
EL10W=Emergency Installed, 10 Watts ⁽⁹⁾

Wiring
PI/CPI=Plug-in Option

Motion Sensors
LB-ERMS360=360° Low Bay Motion Sensor - End of Row
LB-MRMS360=360° Low Bay Motion Sensor - Middle of Row
HB-ERMS360=360° High Bay Motion Sensor - End of Row ⁽⁵⁾
HB-MRMS360=360° High Bay Motion Sensor - Middle of Row ⁽⁵⁾

CCT
L835=3500K
L840=4000K
L850=5000K

ACCESSORIES

(Order Separately)
AYC-Chain/Set=36" Chain Hanger (Use 1 set per fixture)
SCF=Fixed Stem Set (Specify Length)
SCS=Swivel Stem Set (Specify Length)
SCA=Adjustable 48" Stem Set
EYE CHAIN SET/3FT=Eye Bolt Chain (Use 1 set per fixture)
WG/SNF-2FT=2' Wire Guard
WG/SNF-4FT=4' Wire Guard
A1B/Spacer-U=Spacer 1-1/2" to 2-1/2" from ceiling (Use 2 per fixture)
TOGGLE=Single Toggle No. 2 (Specify Length)
Y-TOGGLE=Y Toggle No. 2 (Specify Length)

SHIPPING DATA

Length.	Wt.
2 ft.	4.3 lbs.
4 ft.	8.2 lbs.
8 ft.	15.1 lbs.



ECO5-JP

Dedicated LED fixture with inline driver and interconnects for continuous runs



- Fixture constructed of an extruded aluminum housing/heat sink, polycarbonate lens and PVC 7 Amp male and female interconnects
- Lens available clear or frosted
- Fixture's inline 20 mA driver powered directly with 120V through an accessory grounded cord and plug (ordered separately).
- Fixtures can join directly end to end for continuous runs or be separated with accessory jumper cables in lengths ranging from 6" to 36" (ordered separately)
- Mounting accomplished with accessory spring clips (ordered separately), which enables 360° aiming
- Efficacy is 43 lm-52 lm for 1' length and 80 lm-98 lm for 2'-5' lengths, dependent on color temperature and lens option (consult photometric reports for detailed information)
- Available in 2700K, 3000K, 3500K, 4000K and 5000K, all with a ±50K and typical 82 - 85 CRI
- LED beam angle is 120°
- Fixture operating temperature is 50°C @ 25°C ambient
- Lamp life rated at 50,000 hours
- Limited three year warranty
- IBEW manufactured and labeled
- Made in the U.S.A.

Specification order example: ECO5-JP + 2 + 27 + C (mounting clips, power cord, and jumper cables - ordered separately)

	NOMINAL FIXTURE LENGTH ("L" see below)	COLOR TEMPERATURE (±50K)	LENS TYPE
ECO5-JP	+	+	+
	<ul style="list-style-type: none"> 1: 3.1W - 13-1/4" 2: 3.2W - 22-3/8" 3: 5.6W - 34-1/8" 4: 7.3W - 46-1/8" 5: 9.3W - 57-1/2" 	<ul style="list-style-type: none"> 27: 2700K - 82 CRI 30: 3000K - 84 CRI 35: 3500K - 85 CRI 40: 4000K - 85 CRI 50: 5000K - 85 CRI 	<ul style="list-style-type: none"> C: clear F: frosted

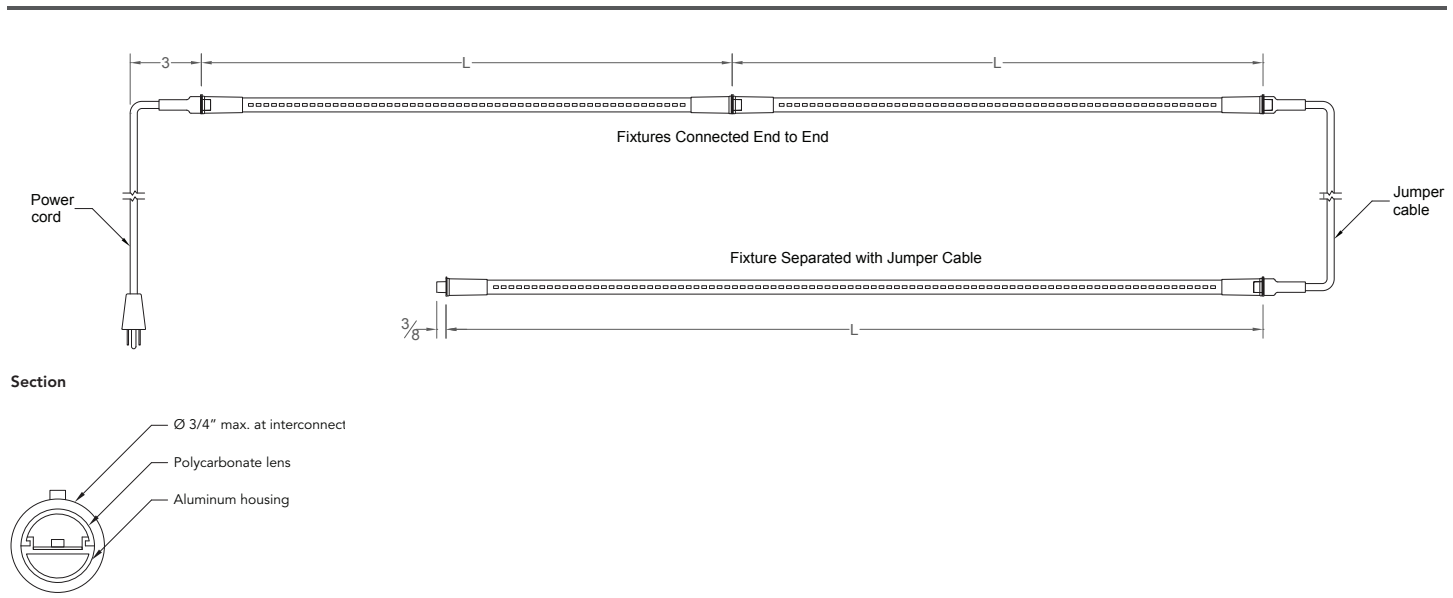

MOUNTING CLIPS |

Note: Two clips required for all lengths



EDT5-CLIP Spring steel mounting clip with mounting hole



EDT5-MAGCLIP Spring steel mounting clip with magnetic base

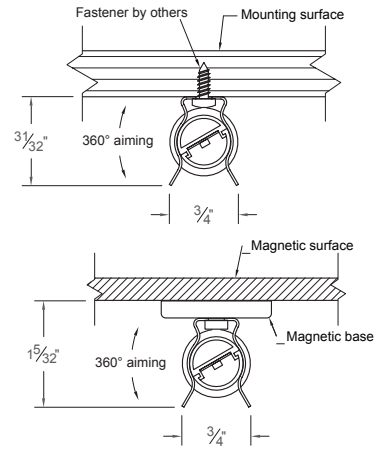

JUMPER CABLES | 18-3 SJT, white jacket

Note: Jumper cables required when ECO5-JP fixtures are not directly connected end to end

- JP-06 6" male to female jumper cable
- JP-12 12" male to female jumper cable
- JP-24 24" male to female jumper cable
- JP-36 36" male to female jumper cable

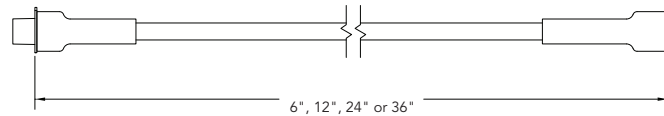

POWER CORD | 18-3 SJT, white jacket

Note: One power cord required for each ECO5-JP fixture run

PCW6-P 6' male to grounded plug

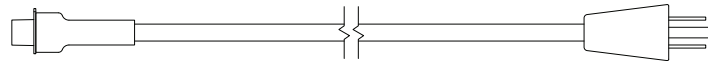

PHOTOMETRY |

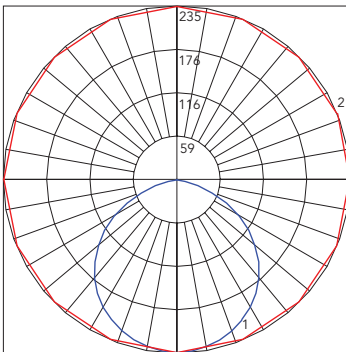

ECO5-JP-4-35-C Maximum Candela = 234.98 Located At Horizontal Angle = 0, Vertical Angle = 0
 # 1 - Vertical Plane Through Horizontal Angles (0 - 180), (Through Max. Cd.)
 # 2 - Horizontal Cone Through Vertical Angle (0) (Through Max. Cd.)

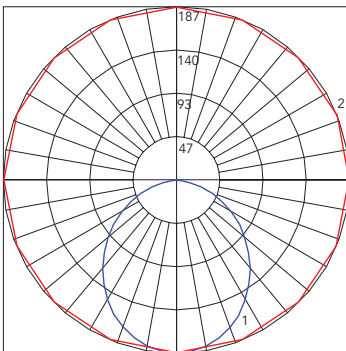

ECO5-JP-4-35-F Maximum Candela = 186.68 Located At Horizontal Angle = 0, Vertical Angle = 0
 # 1 - Vertical Plane Through Horizontal Angles (0 - 180), (Through Max. Cd.)
 # 2 - Horizontal Cone Through Vertical Angle (0) (Through Max. Cd.)

CYLINDRO II DECO LED WITH OPAL ACRYLIC DIFFUSER

DELRAY
LIGHTING
INCORPORATED

CYLINDRO II. DECO



TYPE:

PROJECT:

ORDER NUMBER:

Model#	Finish	LEDs	Voltage	Option
6703-3 ft.	S-Silver	Red	1-120V	C2RD
6704-4 ft.	W-White	Blue	2-277V	BDIM-RGB
6705-5 ft.	K-Black	WW-Warm White		BDMXMOD
		CW-Cool White		BDIM-W
		SQ-RGB sequencer		

Example:

6705	S	WW	1	BDIM-W
------	---	----	---	--------

Traxon Light Drive* (enter quantity)

BTRAXW (white) **BTRAXB** (black)

CANOPY

- Mounts to all standard JBoxes
- Specify **C2RD** for remote driver compartment in accessible ceiling or through access panel.

NOTE: Aircraft cable suspension not recommended for outdoor use, where fixture will be exposed to water, or subject to wind oscillation. Avoid use near HVAC vents and in environments with corrosive chemical vapors, such as swimming pools.

CONSTRUCTION

- Extruded aluminum outer housing with white frosted acrylic diffuser. 6" adjustable power cord and AC cables with push button grippers supplied standard. (Specify **XP** for additional length.)

LED DRIVER

- Driver constant voltage, 100W/24V universal
- Electronic drivers, DMX and dimmer interface housed in canopy or remote gear box (**C2RD**), for easy access.
- Color sequencer standard, with potentiometer speed control; or may be ordered with dimmers or DMX interface. (See second page for details.)

LEDs

- Flexible 5050 24V, universal voltage LED tape light. (The most popular commercial LED light source and, therefore, easily replaced.)
- cUL listed for dry locations.

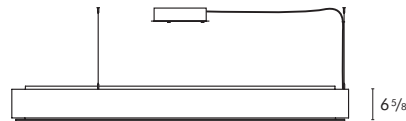

Model	Length	White Watts	Red/Blue Watts	SQ Watts
6703	3 ft.	36	18	36
6704	4 ft.	54	27	54
6705	5 ft.	72	36	72

Specify LED color:

WW-Warm White (2900-3500° K)

CW-Cool White (4700-5500° K)

SQ-RGB sequencer

Red

Blue

DIMENSIONS

Model	ID	OD
6703	34.875"	40.625"
6704	46.9"	52.625"
6705	58.9"	64.625"

BURBANK,
CALIFORNIA,
91505
WWW.
DELRAY
LIGHTING.
COM

LED

6705.CW

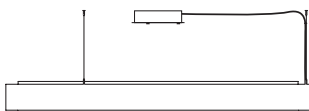

CP DISTRIBUTION

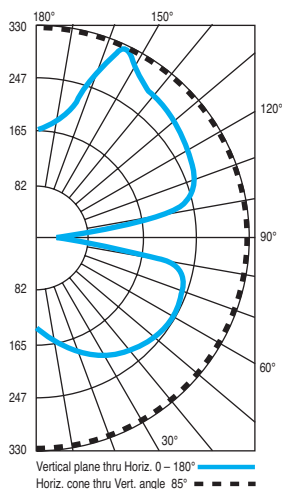

COEFFICIENTS

% CEILING 80 % WALL 70	(20% FLOOR)	
	50	30
0	106	106
1	94	84
2	84	68
3	76	56
4	69	47
5	63	40
6	57	35
7	53	31
8	49	27
9	45	24
10	42	22

NOTES

6705.CW

60W LED strip, cool white
Total lumens: 2,700

CYLINDRO II . DECO

Delray's *Deco* fixtures are cost-effective color and white LED luminaires, available in a variety of classic shapes and geometric configurations. *Deco* fixtures feature flexible 5050 24V, universal voltage LED tape light; the most popular type of commercial LED light source available and, therefore, easily obtained and replaced.

Deco standard LED color options include red and blue, as well as RGB sequencing, which is available with either DMX 512 interface, or 3-dimmer control (2.5 watts per foot). A DMX wall box control is standard.

Deco's white LEDs provide a CCT range decorative glow, and are available in two color temperatures: **WW**—Warm White (2900–3500° K) and **CW**—Cool White (4700–5500° K).

The white tape LEDs consume 4.4 watts and output 270 lumens per foot.

Delray will match white LEDs in up to six fixtures. (For projects requiring additional matched white fixtures, please see *Lux* series.)

Deco fixtures deliver subtle decorative effects with Delray's lowest lumens, wattage, and cost.

cUL listed for dry locations only.

RGB INTERFACE CONTROL OPTIONS

RGB SEQUENCER OPTIONS

- Osram part no. OTRGBSEQUENCER, supplied.

BDIM-RGB

- Osram part no. OTRGBDIM, supplied.
- Dimming control interface for RGB LED that synchronizes the color in multiple fixtures.
- Colors are mixed manually by adjusting three 0-10V wall dimmers, or three 100K Ohm potentiometers. 0-10V converter is required for DMX control. Additional 18/4 control cable, from fixture to canopy, is supplied. Controls by others.

BDMXMOD

- Osram part no. OTDMXRGB supplied.
- DMX control interface for RGB LED.
- Provides DMX control with protocols that meet USITT DMX-512A or DMX512 (DIN 56930-2). No converter is required. DMX controls by others.
- A second 3-conductor control cable to fixture canopy is supplied.

BDIM-White

- For white LEDs only.
- Osram part no. OT96W/24V UNV 0-10V supplied.
- Use with 0–10V, purple/gray wire analog dimmers.

TRAXON LIGHT-DRIVE RGB (order separately)

BTRAXW—white controller

BTRAXB—black controller (shown)

- Stand-alone, wall-mounted (12V power supply included) DMX controller for RGB LED that provides direct access to fixtures in two lighting zones.
- Tune color and brightness with the Light-Drive wheel.
- Two sequence modes enable continuous replay of all saved color settings, as well as a preset color-phase function, which can be adjusted in replay speed.

- Fully dimmable white mode button.
- See www.traxon-usa.com for details.



OPTIONS

REMOTE DRIVER

Driver must be accessible after installation. For suspended and hard lid ceilings with access panels. Canopy mounts to mud ring attached to J-box. Order **C2RD**.

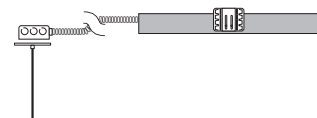

Max. Wiring Distance (at full load)

Wire Size (AWG)	Distance (ft.)
18	18
16	29
14	46
12	71
10	120

ACRYLIC DIFFUSER CLEANING

Warning: Do not clean with ammonia based cleaners (e.g. Windex®). Use only water or cleaners specifically formulated for cleaning plastics.

FEATURES & SPECIFICATIONS

INTENDED USE

Provides maintenance-free, energy-efficient accent and/or task lighting in residential and commercial applications. Mix and match fitters with any number of decorative shades/diffusers from Lithonia Lighting (see shade ordering information on second page) to create a look that perfectly compliments any décor. Ideal for mounting in hallways, over seating areas or flanking mirrors in restrooms.

CONSTRUCTION

Cast aluminum fitters and matching wall brackets are finished in either a bronze or polished brushed nickel. Includes three set screws which hold decorative shades that mount to the inside of the fitter. These shades have a standard 2-1/4" neck.

Decorative shades that mount to the outside of the fitter include decorative finials or decorative rods, three bronze and three polished brushed nickel each, that screw into the fitter.

Decorative shades are available in hand-blown glass, prismatic glass or metal. All decorative shades fit both fitter styles.

Decorative shades sold separately (see shade ordering information on second page).

OPTICS

Each fitter contains three 3000K high-performance LEDs which maintain 274 lumen output at 50,000-hour life.

ELECTRICAL

LED driver is 120V and operates at 60Hz.

Fully dimmable down to 10%. Works with most standard incandescent dimmers. See chart on next page for suggested dimmers.

INSTALLATION

Fitters can be mounted facing either up or down.

All mounting hardware included.

LISTINGS

CUL listed to U.S. and Canadian safety standards.

WARRANTY

Guaranteed for five years against mechanical defects.

Catalog Number
Notes
Type

LED Mini-Sconce Fitters with Mix-and-Match Shades

MWS



Bullet Fitter

Cylinder Fitter



See next page for decorative shade photos.

Dimensions

Bullet Fitter:
Height: 5" (12.7)
Extension From Wall: 6-1/4" (15.9)
All dimensions are inches (centimeters).

Cylinder Fitter:
Height: 4-1/2" (11.4)
Extension From Wall: 5-1/2" (14)

FITTER ORDERING INFORMATION

For shortest lead times, configure products using **bolded options**.

Example: MWSB BZ

MWSB			
Series ¹		Finish	
MWSB	Bullet LED sconce fitter	BZ	Bronze
MWSC	Cylinder LED sconce fitter	BNP	Polished brushed nickel

Notes

- Decorative shades must be ordered separately. See Shade Ordering Information.

SHADE ORDERING INFORMATION

For shortest lead times, configure products using **bolded options**.

Example: DTCL 1005

Model (see product images on next page)

DRBL 1001	Ball shade in opal white finish	DMCN BZ	Metal cone shade in bronze finish	DSCL 1010	Short cylinder shade in white drizzle finish
DRBL 1008	Ball shade in green melon finish	DMCN BNP	Metal cone shade in polished brushed nickel finish	DSBL 1001	Small bell shade in opal white finish
DBEL 1001	Bell shade in opal white finish	DCBL 1009	Concave bell shade in amber twist finish	DTCL 1001	Tall cylinder shade in opal white finish
DBIL 1015	Billet shade in rain drop finish	DGDT 1003	Cylinder dot shade in frosted white finish	DTCL 1005	Tall cylinder shade in apple red finish
DBLT 1001	Bullet shade in opal white finish	DGWN 1003	Cylinder wave shade in frosted white finish	DTCL 1009	Tall cylinder shade in amber twist finish
DBLT 1004	Bullet shade in caramel swirl finish	DGNG 1007	Glass in glass shade in blue finish	DTCL 1010	Tall cylinder shade in white drizzle finish
DCNE 1001	Cone shade in opal white finish	DPRG 1011	Prismatic shade with clear ribbed glass	DTRB 1014	Top rib shade in caramel mocha swirl finish
DCNE 1002	Cone shade in white melon finish	DSCL 1001	Short cylinder shade in opal white finish	DZNT 1003	Zentro shade in frosted white finish
DCNE 1006	Cone shade in cobalt blue finish	DSCL 1005	Short cylinder shade in apple red finish	DZNT 1007	Zentro shade in blue finish
DCNE 1008	Cone shade in green melon finish	DSCL 1009	Short cylinder shade in amber twist finish		

LED Mini-Sconce Fitters and Shades

PHOTOMETRICS

Full photometric data report available within two weeks from request. Consult factory.

Lithonia Lighting

lighting facts®

A Program of the U.S. DOE

Light Output (Lumens) **274**

Watts **9.5**

Lumens per Watt (Efficacy) **28**

Color Accuracy **86**

Color Rendering Index (CRI)

Light Color **2851 (Warm White)**

Correlated Color Temperature (CCT)

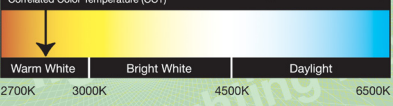

2700K 3000K 3000K 4500K 4500K 6500K

All results are according to IESNA LM-79-2008: Approved Method for the Electrical and Photometric Testing of Solid-State Lighting. The U.S. Department of Energy (DOE) verifies product test data and results.

Visit www.lightingfacts.com for the Label Reference Guide.

Registration Number: NJSM-SB22MA
Model Number: MWS
Type: Surface-mounted fixture (other)

Suggested Dimmers

The MWS Series is designed to operate with most standard Triac Based (Forward Phase-Control or Leading Edge) dimmers and is not compatible with 0-10v dimming systems. The following is a list of dimmers tested with the MWS Series and does not imply any guarantee or warranty of compatibility with a particular application. Unlisted dimmers do not imply non-compatibility.

Manufacturer	Series	Part Number(s)
Leviton	Illumitech	IPI06-XXX
Leviton	Trimatron	6602-1, 6681-X, 6683-X, 6684-X, 700-X, 705-X
Leviton	SureSlide	6631
Leviton	True Touch	6606-1LM
Lutron	Skylark	S-600, S2-LH
Lutron	Nova T	NTELV-600
Lutron	Faetra	FAELV-500-XX
Lutron	Acenti	ACE06-XXX
Lutron	Vizia	VZE04

Note: When the installation exceeds 10 fixtures on a single dimmer or distribution lengths exceed 100 feet, please confirm that the end product performs properly. This is caused by a high degree of variability in the triac dimmers.

SHADES

Shades/diffusers must be ordered separately from fitters. More options may be available (consult factory).

All decorative shades are hand-blown glass (variations in pattern may exist) unless otherwise specified. Shades using decorative rods/finals include rods/finals in both bronze and polished brushed nickel.

									
DBLT 1001 Opal White Bullet 4-1/2"W X 10-1/2" H	DBLT 1004 Caramel Swirl Bullet 4-1/2"W X 10-1/2" H	DTCL 1001 Opal White Tall Cylinder 3-3/8"W X 9-1/4" H	DTCL 1005 Apple Red Tall Cylinder 3-3/8"W X 9-1/4" H	DTCL 1009 Amber Twist Tall Cylinder 3-3/8"W X 9-1/4" H	DTCL 1010 White Drizzle Tall Cylinder 3-3/8"W X 9-1/4" H	DZNT 1003 Frosted White Zentro 3-5/8"W X 10-3/4" H	DZNT 1007 Blue Zentro 3-5/8"W X 10-3/4" H	DGVW 1003 Frosted White Cylinder Wave 4"W X 7-3/4" H	DGD1 1003 Frosted White Cylinder Dot 4"W X 7-3/4" H
									
DCBL 1009 Amber Twist Concave Bell 4-1/2"W X 6" H	DBIL 1015 Rain Drop Billet 4-3/8"W X 5-1/2" H	DBEL 1001 Opal White Bell 4-1/2"W X 10-1/2" H	DRBL 1001 Opal White Ball 4"W X 6" H	DRBL 1008 Green Melon Ball 4"W X 6" H	DGNG 1007 Blue Glass In Glass 5"W X 3-3/4" H	DSCL 1001 Opal White Short Cylinder 3-3/8"W X 6" H	DSCL 1005 Apple Red Short Cylinder 3-3/8"W X 6" H	DSCL 1009 Amber Twist Short Cylinder 3-3/8"W X 6" H	DSCL 1010 White Drizzle Short Cylinder 3-3/8"W X 6" H
									
DTRB 1014 Caramel Mocha Swirl Top Rib 4-3/8"W X 5-1/2" H	DSBL 1001 Opal White Small Bell 4"W X 3" H	DPRG 1011 Clear Ribbed Prismatic (hand cast glass) 6-5/8"W X 3-5/8" H	DCNE 1001 Opal White Cone 5-5/8"W X 3" H	DCNE 1002 White Melon Cone 5-5/8"W X 3" H	DCNE 1006 Cobalt Blue Cone 5-5/8"W X 3" H	DCNE 1008 Green Melon Cone 5-5/8"W X 3" H	DMCN BZ Bronze Cone (Spun metal) 5-3/8"W X 3" H	DMCN BNP Polished Brushed Nickel Cone (Spun metal) 5-3/8"W X 3" H	

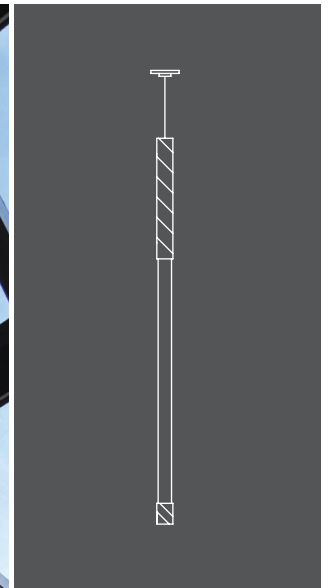

PAVO Interior Pendant

Integral Ballast
Page 61





SIP11575 shown with 24" Cord

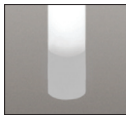

SIP11575 shown with 24" Cord & ACC

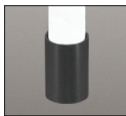

Cord Mounted 2 Lamp Fixture

	W	H	OAH
SIP11575	2.5"	71.0"	120.0"

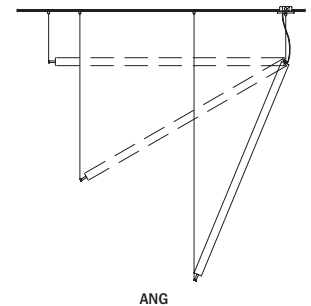
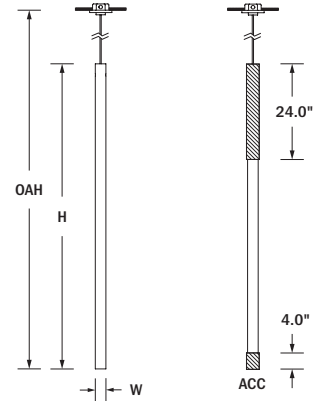
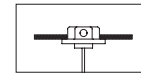

Specifications:

- 48" white power cord standard with a white plastic canopy that fits over a standard 4" octagonal junction box.
- Aluminum construction provides durable protection for internal components and is recyclable.
- Opal diffuser lens enhances a space with filtered illumination.
- External fasteners are not visible, providing a clean fixture design.
- Standard thermoset polyester powder coat paint provides durable protection in a palette of color options. Custom colors available upon request.
- Integral electronic ballast utilizes the latest energy-saving technology to maintain consistent color temperature, CRI and lumen maintenance, while eliminating the need for remote mounting and simplifying installation.
- Fixture design allows relamping without the use of tools, simplifying maintenance.
- Consult factory for downlight option.
- ETL listed to UL standards (US and Canada) for use in damp locations. Not recommended for exterior applications.

SELECT STYLE	SELECT LAMPING	SELECT VOLTAGE	SELECT OPTIONS	SELECT FINISH (for ACC or CAS only)												
<input type="text" value="SIP11575"/>	<input type="text" value="2F28<sup>1</sup> (2) F28WT5/Mini Bipin"/>	<input type="text" value="120 277"/>	<table border="1"> <tr><td>F</td><td>Fusing</td></tr> <tr><td>ACC</td><td>Decorative Accent Tube</td></tr> <tr><td>MBP</td><td>Metal Braided Power Cord</td></tr> <tr><td>CAS</td><td>5" Canopy & 48" Stem</td></tr> <tr><td>ANG²</td><td>Adjustable Angle Mount</td></tr> <tr><td>DM</td><td>Dimming</td></tr> </table>	F	Fusing	ACC	Decorative Accent Tube	MBP	Metal Braided Power Cord	CAS	5" Canopy & 48" Stem	ANG ²	Adjustable Angle Mount	DM	Dimming	<input type="text" value="PT_ Painted. (Include Paint Number)"/>
F	Fusing															
ACC	Decorative Accent Tube															
MBP	Metal Braided Power Cord															
CAS	5" Canopy & 48" Stem															
ANG ²	Adjustable Angle Mount															
DM	Dimming															
<p>¹ T5 FL linear lamp(s) not included.</p>		<p>See STILE Finish Selection Guide on page 79.</p>														

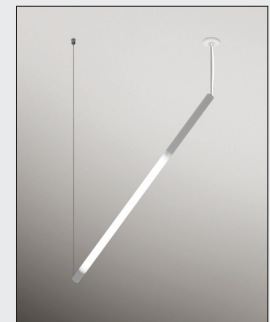

ANG Angle mount.

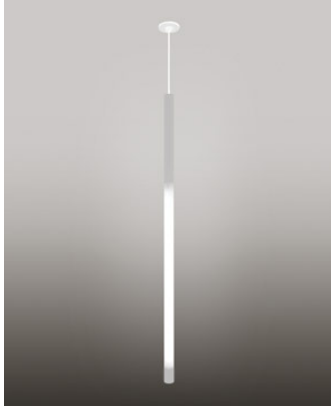
PAVO INTERIOR PENDANT
SIP11575

Minimalist form meets functional lighting with the Pavo pendant. A sleek 2.5 inch diameter acrylic lens encloses two T5 lamps and an integral ballast. Power cord suspension adds to the Pavo's minimalist flair by eliminating unnecessary aircraft cables or stems. The Pavo works great in high ceiling applications such as churches, stairwells, and atriums. A splash of color or metal finish can be added to the fixture with the optional tube cover accessory.

JOB NAME

TYPE

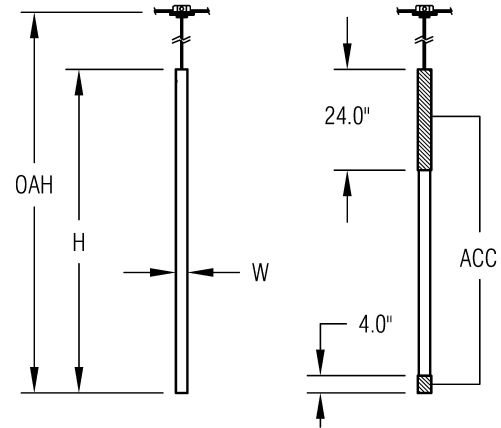

Dimensions

W
2.5 in
6.4 cm

Weight

Hanging weight: 25.0 lb (11.4 kg).

Features

- Aluminum construction provides durable protection for internal components and is recyclable.
- Opal acrylic diffuser lens enhances a space with filtered illumination.
- External fasteners are not visible, providing a clean fixture design.
- Fixture design allows relamping without the use of tools, simplifying maintenance.
- Standard thermoset polyester powder coat paint provides durable protection in a palette of color options. Custom colors available upon request.
- Electronic ballast increases energy savings and performance.
- Integral ballast simplifies installation by eliminating the need to locate, mount and wire a remote ballast.

Technical Notes

Electrical

- 48" white power cord standard.
- Class "A" sound rated ballast for use in low ambient noise applications.
- Meets NEC 410.73 double-ended, fluorescent lamp ballast disconnect requirements.
- ETL listed to UL standards (US and Canada) for use in damp locations. Not recommended for exterior applications.



Mounting

- The white plastic canopy fits over a standard 4" octagonal junction box.
- CAS versions include a 48" painted white stem (PT02).

Additional Documents

MODEL NUMBER	LAMPING	FINISH	VOLTAGE	LAMP OPTIONS	OPTIONS	ACCENT	ACCENT FINISH

Not all options are available in all configurations, consult factory for details.

Lamping	Photometry	Voltage	Options
2F14 ¹	 ² 2F14WT5/Mini Bipin	120V 120 Volt	ANG ⁵ Adjustable Angle Mount
2F21 ³	 ² 2F21WT5/Mini Bipin	277V 277 Volt	CAS 5" Canopy & 48" Stem
2F28 ⁴	 ² 2F28WT5/Mini Bipin	ITL66875	ACC Decorative Accents
		Lamp Options	Accent
		DM Dimming	ACC Decorative Accents
		F Fusing	

¹ H=46.5in (118.1cm) OAH=96.5in (245.1cm)
² T5 & T8 Fluorescent Linear Lamp(s) Not Included
³ H=58.3in (148.1cm) OAH=108.3in (275.1cm)
⁴ H=70.0in (177.8cm) OAH=120.0in (304.8cm)
⁵ Not available with CAS.

Painted Finishes

PT01 SuperWhite	PT07 Light Taupe	PT13 Warm Gray	PT19 Blue	PT29 Red Brass	PT42 Sky Blue	PT48 Brass
PT02 White	PT08 Medium Taupe	PT14 Light Gray	PT20 Dark Green	PT31 Medium Bronze	PT43 Teal	PT49 Bronze
PT03 Morning Light	PT09 Medium Gray	PT15 Sage	PT21 Pearl White	PT32 Dark Bronze	PT44 Green	
PT04 Warm White	PT10 Dark Gray	PT16 Spruce	PT22 Platinum	PT33 Dark Blue	PT45 Purple	
PT05 Putty	PT11 Black	PT17 Red	PT27 Deep Copper	PT40 Yellow	PT46 Aluminum	
PT06 Warm Beige	PT12 Dark Chocolate	PT18 Deep Red	PT28 Dark Stainless	PT41 Orange	PT47 Deep Red Brass	

Metal and Plated Finishes

BAL Brushed Aluminum

Kit Details



CAS
5" Canopy & 48" Stem



ANG
Adjustable Angle Mount

with LED

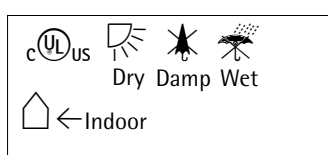
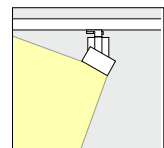
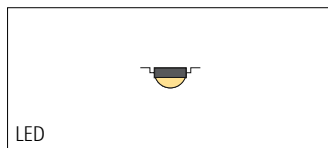
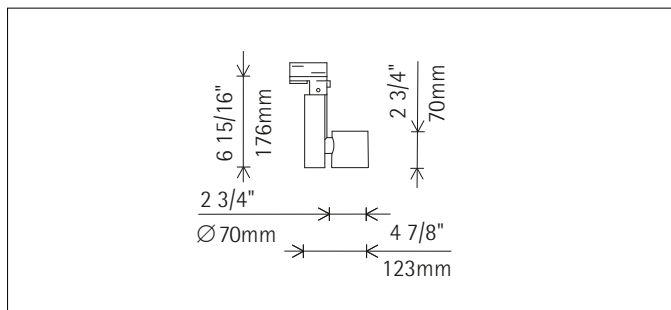

71015.023 White
 LED 6W 570lm 3000K warm white
 Version 2
 Spherolit lens, wallwash

Product description

Cylindrical light head: cast aluminum, powder-coated. 270° tilt.
 Housing: plastic, rotatable on turning adapter through 360°.
 Electronic control gear 120V, 60Hz.
 Turning adapter for ERCO 2-circuit track: plastic.
 LED module: high-power LEDs on metal-core PCB. SDCM<2. CRI>90.
 L80/B10 50000h. Collimating lens made of optical polymer.
 Weight 1.26lbs / 0.57kg

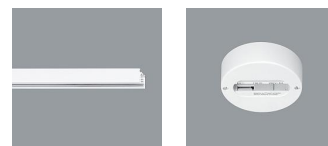

Mounting
 ERCO 2-circuit track
 Hi-trac 2-circuit track
 1-circuit singlet

ERCO Lighting Inc.
 160 Raritan Center Parkway
 Suite 10
 Edison, NJ 08837
 USA
 Tel.: +1 732 225 8856
 Fax: +1 732 225 8857
 info.us@erco.com

Technical region: 120V/60Hz
 We reserve the right to make technical and design changes.
 Edition: 04.03.2014
 Current version under
 www.erco.com/71015.023

Planning data

Illuminance (fc)

Specifications:

Number of luminaires n > 5

Light loss factor 1.00

Without indirect component

Without peripheral area

Wall height (ft) 10

Angle of tilt 35°

LED 6W 570lm 3000K

Offset from wall (ft)	3		3		4		4	
Luminaire spacing (ft)	3		4		4		5	
Distance from ceiling (ft)	below the luminaire	between the luminaires	below the luminaire	between the luminaires	below the luminaire	between the luminaires	below the luminaire	between the luminaires
1.000	5	5	4	4	2	3	2	2
2.000	12	12	10	9	5	6	4	4
3.000	16	17	14	12	8	8	7	6
4.000	17	18	15	13	9	10	8	7
5.000	16	16	13	12	10	10	8	8
6.000	14	14	12	10	10	9	8	7
7.000	12	12	9	9	9	9	7	7
8.000	10	9	7	7	8	8	7	6
9.000	7	7	6	6	7	7	6	5



6" LED Pendant Mount Cylinder **LD6LED4P**

Wet Location
120V, 277V
High Output

APPLICATIONS:

LiteForms™ LD6LED4D Series is a 6" direct wall mount LED cylinder designed to combine superior brightness control with energy savings and long lamp life. Suitable for a variety of commercial, retail, and institutional applications to achieve illumination patterns on vertical walls or columns. Optical lens options in spot, medium, or wide distribution are ideal for higher ceiling applications such as transportation terminals or atrium areas. Suitable for use in ambient temperatures up to 30°C (86°F) during operation.

HOUSING:

Seamless .058" thick extruded aluminum cylinder body with durable powder coat paint finish in a variety of architectural colors including Prescolite's exclusive Zet, metallic silver.

REFLECTOR:

High purity spun aluminum self-flanged reflector with iridescence suppressed Alzak anodized finish retained by factory installed spring clips and safety cable for ease of maintenance. Provided with integral clear tempered glass lens to protect LEDs.

LED LIGHT ENGINE:

High output LED light engine equipped with (10) high brightness white LEDs (2700K, 3500K, 4000K, or 5000K) on a metal clad circuit board. Secured to an integral die cast aluminum heat sink for excellent thermal

management. System designed for optimal life and lumen maintenance (50,000 hours at 70% average lumen maintenance*). *LED life calculations are based upon maintaining application LED junction temperatures and drive currents at or below manufacturer's requirements per IESNA-LM-80-08 test data.

Optics: Vacuum metallized injection molded optical reflector features (10) parabolic LED modules with Prescolite's patented (U.S. Patent No. 6,254,256) American Matte™ finish to produce uniform illumination. Optional optical lenses provide a choice of spot, medium, or wide distribution for added versatility.

LED DRIVER:

Energy efficient solid state constant current electronic driver with 50,000 hour minimum anticipated life. Meets UL Class 2, inherent short-circuit protection, self limited, overload protected.

INSTALLATION:

Easy installation onto standard J-Box.

CERTIFICATIONS:

CSA certified to US and Canadian safety standards. Suitable for wet locations.

WARRANTY:

3 year warranty
5 year warranty available*
*(See NOTES on page 3)

DATE: _____ TYPE: _____

FIRM NAME: _____

PROJECT: _____



For conversion to millimeters,
multiply inches by 25.4
Not to Scale

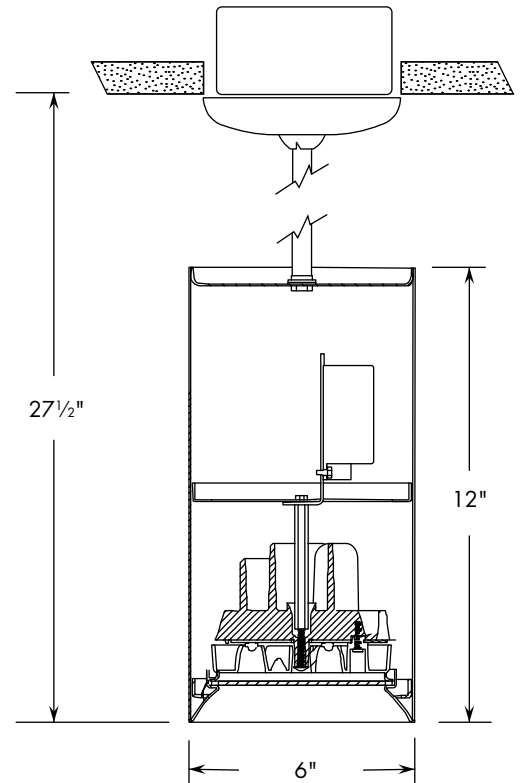

CATALOG NUMBER:

EXAMPLE: LD6LED4PW35K8FL35 277V Z

CYLINDER	LED COLOR	LED COLOR TEMP	CRI	BEAM ANGLE	VOLTAGE	REF. COLOR	CYLINDER FINISH
<input type="checkbox"/> LD6LED4P 6" Pendant mount high output LED cylinder	<input type="checkbox"/> W White	<input type="checkbox"/> 27K 2700 Kelvin <input type="checkbox"/> 35K 3500 Kelvin <input type="checkbox"/> 40K 4000 Kelvin <input type="checkbox"/> 50K 5000 Kelvin	<input type="checkbox"/> 7 Nominal 70+ CRI <input type="checkbox"/> 8 Nominal 80+ CRI	<input type="checkbox"/> Blank Vacuum metallized reflector with 45° cutoff <input type="checkbox"/> FL35 Lensed optic with 35° wide distribution and Zet painted faceplate <input type="checkbox"/> MD25 Lensed optic with 25° medium distribution and Zet painted faceplate <input type="checkbox"/> SP18 Lensed optic with 18° spot distribution and Zet painted faceplate	<input type="checkbox"/> Blank 120V only <input type="checkbox"/> 277V 120/277V REF. FINISH <input type="checkbox"/> Blank Specular <input type="checkbox"/> SS Semi-Specular	<input type="checkbox"/> Blank Clear Alzak <input type="checkbox"/> CG Champagne Gold Alzak <input type="checkbox"/> BL Black Alzak <input type="checkbox"/> WE Wheat Alzak <input type="checkbox"/> LW Light Wheat Alzak <input type="checkbox"/> PW Pewter Alzak <input type="checkbox"/> WH White Paint	<input type="checkbox"/> WH White <input type="checkbox"/> BL Black <input type="checkbox"/> Z Zet <input type="checkbox"/> BA Brushed Aluminum <input type="checkbox"/> BZ Bronze

PHOTOMETRIC DATA

LiteForms™™ - LD6LED4D - 6" Pendant Mount LED Cylinder

DRIVER DATA

	LD6LED4	LD6LED4 277V
Input Voltage	120V +/- 10%	120/277V
Input Frequency	50/60 Hz	50/60 Hz
Input Current	0.235A	0.23A/0.13A
Input Power	28W	27.5/28.5W
Constant Current Output	1400mA	1400mA
Power Factor	≥0.90	0.98/0.78
THD	<20%	<20%
EMI Filtering	FCC 47CFR Part 15, Class A	FCC 47CFR Part 15, Class B
Operating Temperature	-40°C to 60°C	-30°C to 60°C
Dimming	No	No
Over-voltage, over-current, short-circuit protected		

LUMEN MULTIPLIER

	2700K	3500K	4000K	5000K
70+ CRI	1.06	1.13	1.20	1.41
80+ CRI	0.89	Baseline	1.10	1.15

Note: Multipliers shown are based on LED manufacturer data and can be used to approximate the lumen intensity of a fixture with different LED color temperature and/or CRI with identical optical configuration and reflector finish. For reference only.

LD6LED4PW35K8

LED Light Engine: (10) LED Array 3500K Mid CRI
System Wattage: 27.4
Fixture delivered lumens: 877
Fixture Efficacy: 32
Spacing Criteria: 0.8

ZONAL LUMEN SUMMARY

ZONE	LUMENS	%LUMINAIRE
0-30	593	67.7
0-40	748	85.3
0-60	873	99.6
0-90	877	100.0
90-180	0	0.0
0-180	877	100.0

LUMINANCE DATA IN CANDELA/SQ. METER

Angle in Vertical	Average - 0°
45°	17635
55°	5096
65°	692
75°	0
85°	0

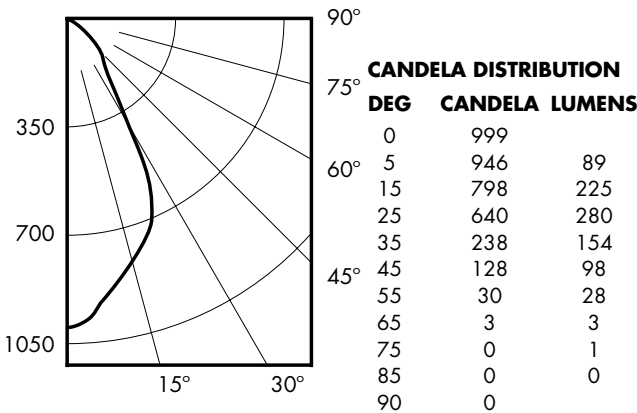

Test No. 2925

Tested at 25°C Ambient in accordance to IESNA LM-79-2008

COEFFICIENTS OF UTILIZATION Zonal Cavity Method

Room Cavity Ratio	% Effective Floor Cavity Reflectance																
	80%			70%			50%			30%			10%				
	70	50	30	70	50	30	70	50	30	70	50	30	70	50	30		
1	113	110	108	106	111	108	106	104	104	102	101	100	99	98	97	96	95
2	107	102	98	95	105	101	97	93	97	94	91	94	92	99	92	89	88
3	102	95	90	86	100	94	89	85	91	87	84	88	85	82	86	83	81
4	96	88	83	78	94	87	82	78	85	80	77	83	79	76	81	78	75
5	91	82	76	72	89	81	76	71	80	75	71	78	74	70	76	73	69
6	86	77	71	66	85	76	70	66	75	69	66	73	69	65	72	68	65
7	82	72	66	61	80	71	65	61	70	65	61	69	64	61	68	64	60
8	78	68	62	57	76	67	61	57	66	61	57	65	60	57	64	60	56
9	74	64	58	54	73	63	57	53	62	57	53	61	57	53	61	56	53
10	70	60	54	50	69	60	54	50	59	54	50	58	53	50	57	53	50

LD6LED4PW35K8

Test No. 2925

LD6LED4PW35K8FL35

LED Light Engine: (10) LED Array 3500K Mid CRI with Flood Lens
System Wattage: 27.4
Fixture delivered lumens: 959
Fixture Efficacy: 35
Spacing Criteria: 0.6

ZONAL LUMEN SUMMARY

ZONE	LUMENS	%LUMINAIRE
0-30	826	86.1
0-40	916	95.5
0-60	954	99.5
0-90	959	100.0
90-180	0	0.0
0-180	959	100.0

LUMINANCE DATA IN CANDELA/SQ. METER

Angle in Vertical	Average - 0°
45°	4822
55°	1359
65°	922
75°	376
85°	0

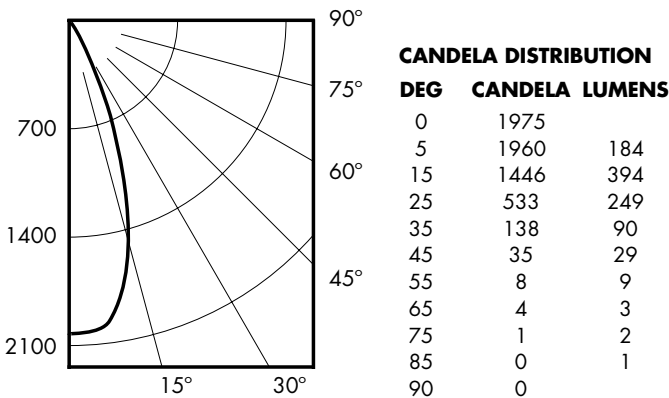

Test No. 2924

Tested at 25°C Ambient in accordance to IESNA LM-79-2008

COEFFICIENTS OF UTILIZATION Zonal Cavity Method

Room Cavity Ratio	% Effective Floor Cavity Reflectance																
	80%			70%			50%			30%			10%				
	70	50	30	70	50	30	70	50	30	70	50	30	70	50	30		
1	114	112	109	107	112	110	108	106	106	104	103	102	101	99	98	98	97
2	109	105	102	99	107	103	100	98	100	98	95	97	95	93	95	93	91
3	105	99	95	92	103	98	94	91	95	92	89	93	90	88	91	89	87
4	101	94	89	86	99	93	89	85	91	87	84	89	86	83	87	85	82
5	97	89	84	81	95	89	84	80	87	83	80	85	82	79	84	81	78
6	93	85	80	76	91	84	80	76	83	79	76	82	78	75	81	77	75
7	89	81	76	73	88	81	76	72	80	75	72	78	75	72	77	74	71
8	86	78	73	69	85	77	72	69	76	72	69	75	71	69	74	71	68
9	83	75	70	66	82	74	69	66	73	69	66	72	68	66	72	68	65
10	80	72	67	63	79	71	66	63	70	66	63	70	66	63	69	65	63

LD6LED4PW35K8FL35

Test No. 2924

NOTES

Refer to www.prescolite.com for additional photometric tests (IES Files).



Web: www.prescolite.com • Tech Support: (888) 777-4832
701 Millennium Boulevard • Greenville, SC 29607 U.S.A. • Phone (864) 678-1000
Copyright ©2011 Prescolite, Inc., a division of Hubbell Lighting, Inc. All Rights Reserved
Specifications subject to change without notice. • Printed in U.S.A. • LFOLED-011 • 2/24/11



Hubbell Lighting, Inc.

PHOTOMETRIC DATA

LiteForms™™ - LD6LED4D - 6" Pendant Mount LED Cylinder

LD6LED4PW35K8MD25

LED Light Engine: (10) LED Array 3500K Mid CRI with Medium Lens
 System Wattage: 27.4
 Fixture delivered lumens: 967
 Fixture Efficacy: 35.2
 Spacing Criteria: 0.4

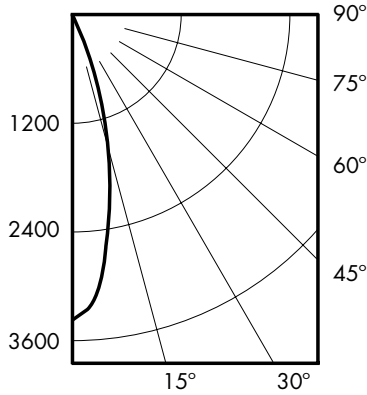

CANDELA DISTRIBUTION		
DEG	CANDELA	LUMENS
0	3515	
5	3164	280
15	1399	389
25	404	191
35	108	70
45	33	26
55	9	9
65	2	1
75	0	1
85	0	0
90	0	

Test No. 2923
 Tested at 25°C Ambient in accordance to IESNA LM-79-2008

ZONAL LUMEN SUMMARY

ZONE	LUMENS	%LUMINAIRE
0-30	859	88.9
0-40	930	96.2
0-60	965	99.8
0-90	967	100.0
90-180	0	0.0
0-180	967	100.0

LUMINANCE DATA IN CANDELA/SQ. METER

Angle in Vertical	Average - 0°
45°	4547
55°	1529
65°	461
75°	0
85°	0

COEFFICIENTS OF UTILIZATION Zonal Cavity Method

Room Cavity Ratio	% Effective Floor Cavity Reflectance																
	80%	70%	50%	30%	10%												
	20% Effective Floor Cavity Reflectance																
	% Wall Reflectance																
	70	50	30	10	70	50	30	10	50	30	10						
1	115	112	110	108	112	110	108	107	106	105	103	103	101	100	99	98	97
2	110	106	103	100	108	105	102	99	102	99	97	99	97	95	96	94	93
3	106	101	97	94	104	100	96	93	97	94	92	95	93	90	93	91	89
4	102	97	92	89	101	95	91	88	93	90	87	92	89	86	90	87	85
5	99	92	88	84	97	91	87	84	90	86	83	88	85	83	87	84	82
6	96	89	84	81	94	88	84	80	86	83	80	85	82	79	84	81	79
7	92	85	81	77	91	85	80	77	83	80	77	82	79	76	81	78	76
8	89	82	77	74	88	82	77	74	81	77	74	80	76	74	79	76	73
9	87	79	75	72	86	79	74	71	78	74	71	77	74	71	76	73	71
10	84	77	72	69	83	76	72	69	75	72	69	75	71	69	74	71	69

LD6LED4PW35K8MD25 Test No. 2923

LD6LED4PW35K8SP18

LED Light Engine: (10) LED Array 3500K Mid CRI with Spot Lens
 System Wattage: 27.5
 Fixture delivered lumens: 1108
 Fixture Efficacy: 40.2
 Spacing Criteria: 0.2

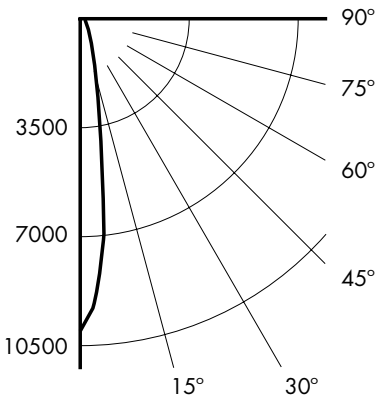

CANDELA DISTRIBUTION		
DEG	CANDELA	LUMENS
0	10107	
5	6461	527
15	1283	382
25	295	144
35	52	34
45	19	15
55	6	4
65	1	1
75	0	1
85	0	0
90	0	

Test No. 2922
 Tested at 25°C Ambient in accordance to IESNA LM-79-2008

ZONAL LUMEN SUMMARY

ZONE	LUMENS	%LUMINAIRE
0-30	1052	95.0
0-40	1087	98.1
0-60	1106	99.8
0-90	1108	100.0
90-180	0	0.0
0-180	1108	100.0

LUMINANCE DATA IN CANDELA/SQ. METER

Angle in Vertical	Average - 0°
45°	2618
55°	1019
65°	231
75°	0
85°	0

COEFFICIENTS OF UTILIZATION Zonal Cavity Method

Room Cavity Ratio	% Effective Floor Cavity Reflectance																
	80%	70%	50%	30%	10%												
	20% Effective Floor Cavity Reflectance																
	% Wall Reflectance																
	70	50	30	10	70	50	30	10	50	30	10						
1	115	113	111	108	113	111	110	108	107	106	105	104	103	102	100	99	99
2	112	108	106	102	110	107	104	102	104	102	100	101	99	98	98	97	96
3	109	104	101	97	107	103	100	97	100	98	96	98	96	94	96	94	93
4	106	101	97	94	104	99	96	94	98	95	92	96	93	91	94	92	90
5	103	97	93	90	101	96	93	90	95	92	90	93	91	89	92	90	88
6	100	94	91	88	99	94	90	88	92	89	87	91	89	86	90	88	86
7	98	92	88	85	97	91	88	85	90	87	85	89	86	84	88	86	84
8	95	89	86	83	95	89	85	83	88	85	83	87	84	82	86	84	82
9	93	87	84	81	93	87	83	81	86	83	81	85	83	81	85	82	80
10	91	85	82	79	91	85	82	79	84	81	79	84	81	79	83	81	79

LD6LED4PW35K8SP18 Test No. 2922

NOTES: Refer to www.prescolite.com for additional photometric tests (IES Files).

- 5 year warranty requires product registration. Warranty limited to repair and replacement of defective parts of the LED system and does not include labor or installation after first year. See www.prescolite.com for details.
- Operation in ambient temperatures higher than those specified may shorten life and will void warranty.



Web: www.prescolite.com • Tech Support: (888) 777-4832
 701 Millennium Boulevard • Greenville, SC 29607 U.S.A. • Phone (864) 678-1000
 Copyright ©2011 Prescolite, Inc., a division of Hubbell Lighting, Inc. All Rights Reserved
 Specifications subject to change without notice. • Printed in U.S.A. • LFOLED-011 • 2/24/11



Hubbell Lighting, Inc.

Pippa LED

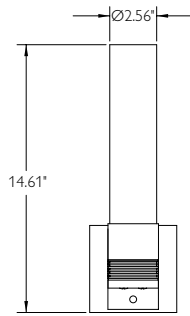

- ADA compliant five layered hand-blown glass sconce with white enamel inner casing
- One 2.4W LED in 2700K or 3500K color temperature
- Integral LED driver
- Requires 12V magnetic transformer which can be remote mounted up to 10 feet away or integral to fixture

Translite sconce

Ordering code



Fixture

PPL5
Pippa LED Sconce

Diffuser color



VR
Mt. Vernon Red



SW
Sausalito White



TG
Turner Gold



PW
Polar White

Metal finish

AL
Satin Aluminum

PN
Polished Nickel

GB
Gloss Black

WH
White

Lamping

N2-W
One 2.4 watt LED
2700K

N2-N
One 2.4 watt LED
3500K

Transformer

R
Remote transformer
(ordered separately)¹

T
Integral transformer²

¹Fixture mounts to 2" x 3" switch box when used with remote transformer.
²Fixture supplied with toroidal transformer. Requires a 4" square, 2" deep j-box (by others).

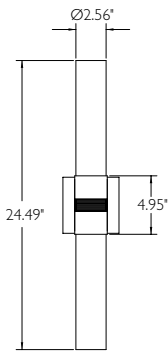

- ADA compliant five layered hand-blown glass sconce with white enamel inner casing
- Two 2.4W LED in 2700K or 3500K color temperature
- Integral LED driver
- Requires 12V magnetic transformer which can be remote mounted up to 10 feet away or integral to fixture

Pippa LED Double

Translite sconce

Ordering code



Fixture

PPL5D
Pippa LED Double Sconce

Diffuser color



VR
Mt. Vernon Red



SW
Sausalito White



TG
Turner Gold



PW
Polar White

Metal finish

AL
Satin Aluminum

PN
Polished Nickel

GB
Gloss Black

WH
White

Lamping

N2-W
Two 2.4 watt LEDs
2700K

N2-N
Two 2.4 watt LEDs
3500K

Transformer

R
Remote transformer
(ordered separately)¹

T
Integral transformer²

¹Fixture mounts to 2" x 3" switch box when used with remote transformer.
²Fixture supplied with toroidal transformer. Requires a 4" square, 2" deep j-box (by others).

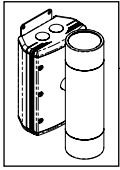

BKSSL
SOLID STATE LIGHTING

THE POWER OF



OLYMPUS™
on PM3

PROJECT:	
TYPE:	
CATALOG NUMBER:	
SOURCE:	
NOTES:	

CATALOG NUMBER LOGIC

OL	LED							PM3				
-----------	------------	--	--	--	--	--	--	------------	--	--	--	--

Example: **OL** - **LED** -x21/X21- **FL/FL** - **SAP** - **12/12** - **11/11** - **B** - **PM3** - **SM** -**D15/D15-** **MT** -

Series _____
OL - Olympus Series™

Source _____
LED - 'x' Module with Cold Phosphor Technology

LED Type (Select Up and Down) _____
x21 - 15WLED/2700K
x22 - 15WLED/3000K
x23 - 15WLED/4000K

Optics (Select Up and Down) _____
SP - Spot (20°) **FL** - Flood (40°) **WFL** - Wide Flood (60°)

Finish _____

Standard Finish			Premium Finish		
Powder Coat Color	Satin	Wrinkle	ABP	CMG	RMG
Bronze	BZP	BZW	Antique Brass Powder	Cascade Mountain Granite	Rocky Mountain Granite
Black	BLP	BLW	Aleutian Mountain Granite	Cracked Ice	SDS Sonoran Desert Sandstone
White (Gloss)	WHP	WHW	Antique White	CRM Cream	SMG Sierra Mountain Granite
Aluminum	SAP	—	Black Chrome	HUG Hunter Green	TXF Textured Forest
Verde	—	VER	Beige	MDS Mojave Desert Sandstone	WCP Weathered Copper
			Brown Patina Powder	NBP Natural Brass Powder	WIR Weathered Iron
			Clear Anodized Powder	OCP Old Copper	<i>Also available in RAL Finishes See submittal SUB-1439-00</i>

Lens Type (Select Up and Down) _____
9 - Clear (Standard) **10** - Spread Lens* **12** - Soft Focus Lens* **13** - Rectilinear Lens*

Shielding (Select Up and Down) _____
11 - Honeycomb Baffle*
**Accommodates up to 2 Lens/Shielding media*

Cap Style _____
A - 45° **B** - 90° **C** - Flush **D** - 45° without Weep Hole (Interior Use Only) **E** - 90° without Weep Hole (Interior Use Only)

Driver Housing _____
PM3 - Universal Power Module 3

Mounting _____
CR - Round CamLock™ **SM** - Surface Mount (requires side conduit entry)

Driver Type _____
D15 - 15W Driver (non-dimming)
D15INC - 15W Dimming Driver (for use with Incandescent Dimmer)*
**120V only*

Input Voltage _____
120 - 120 VAC Input (for use with D15INC only)
MT - 120-277 VAC Input

Option _____
MB - Mounting Brackets (Optional for CT or CR Mounting only)

B-K LIGHTING	40429 Brickyard Drive • Madera, CA 93636 • USA 559.438.5800 • FAX 559.438.5900 www.bklighting.com • info@bklighting.com	SUBMITTAL DATE	DRAWING NUMBER
		8-28-13	SUB-2006-00

THIS DOCUMENT CONTAINS PROPRIETARY INFORMATION OF B-K LIGHTING, INC. AND ITS RECEIPT OR POSSESSION DOES NOT CONVEY ANY RIGHTS TO REPRODUCE, DISCLOSE ITS CONTENTS, OR TO MANUFACTURE, USE OR SELL ANYTHING IT MAY DESCRIBE. REPRODUCTION, DISCLOSURE OR USE WITHOUT SPECIFIC WRITTEN AUTHORIZATION OF B-K LIGHTING, INC. IS STRICTLY FORBIDDEN.

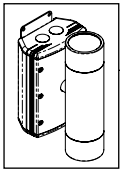

BKSSL
SOLID STATE LIGHTING

THE POWER OF



OLYMPUS™
on PM3

PROJECT:

TYPE:

SURFACE MOUNT

FRONT VIEW

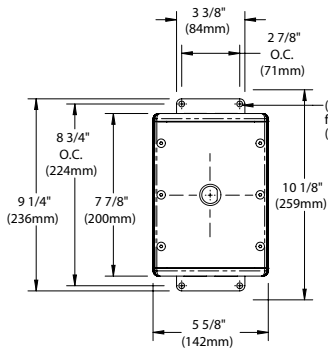

SIDE VIEW

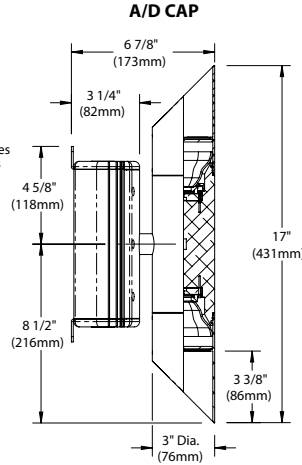

B/E CAP

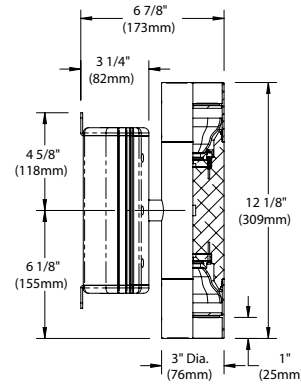

C CAP

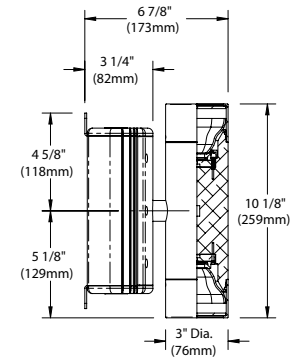

END VIEW

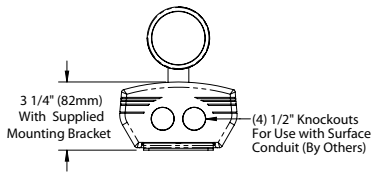

CAMLOCK™ MOUNT

FRONT VIEW

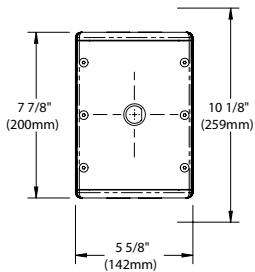

SIDE VIEW

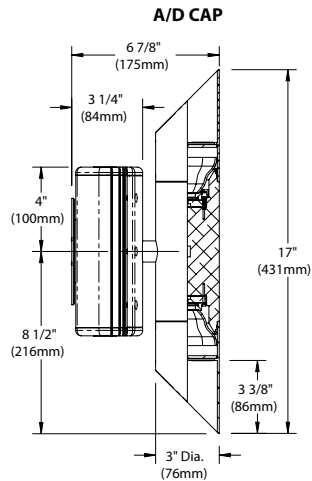

B/E CAP

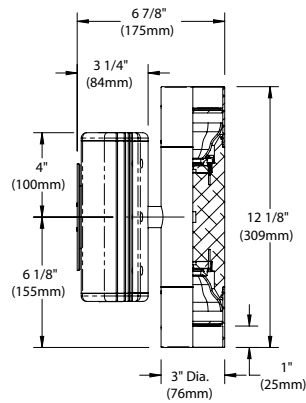

C CAP

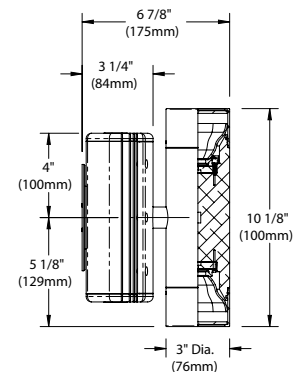

END VIEW

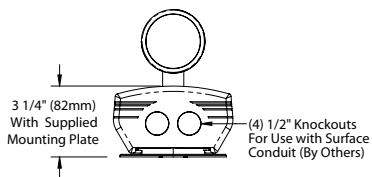

CAMLOCK CANOPY

ROUND

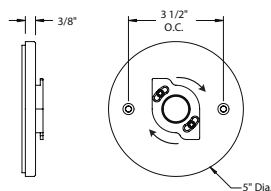

All dimensions indicated on this submittal are nominal.
Contact Technical Sales if you require more stringent specifications.

B-K LIGHTING

40429 Brickyard Drive • Madera, CA 93636 • USA
559.438.5800 • FAX 559.438.5900
www.bklighting.com • info@bklighting.com

SUBMITTAL DATE
8-28-13

DRAWING NUMBER
SUB-2006-00

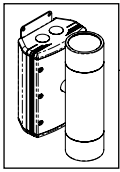

BKSSL
SOLID STATE LIGHTING

THE POWER OF



OLYMPUS™
on PM3

PROJECT:

TYPE:

LM79 DATA

BK No.	CCT (Typ.)	CRI (Ra. Typ.)	Color Consistency	Input Watts (Typ.)
x21	2700K	>80	±40K	15
x22	3000K	>80	±50K	15
x23	4000K	>80	±70K	15

L70 DATA

Minimum Rated Life (hrs.) 70% of initial lumens (L70)
50,000
50,000
50,000

OPTICAL DATA

Beam Type	Angle
Spot	20°
Flood	40°
Wide Flood	60°

DRIVER ELECTRICAL DATA

TYPE	AC INPUT RANGE	Frequency Hz	DIMMING	POWER FACTOR	THD	OPER. AMBIENT TEMPERATURE	DIMMER TYPE	DIMMER RANGE
D15	120/208/240/277	50/60	NO	>0.92	≤20%	-30° C ~ 50°C	—	—
D15INC	120	50/60	YES	>0.96	≤20%	-30° C ~ 60°C	Incandescent	10-100%

SPECIFICATIONS

GreenSource Initiative™

Metal and packaging components are made from recycled materials. Manufactured using renewable solar energy, produced onsite. Returnable to manufacturer at end of life to ensure cradle-to-cradle handling. Packaging contains no chlorofluorocarbons (CFC's). Use of this product may qualify for GreenSource efficacy and recycling rebate(s). Consult www.bklighting.com/greensource for program requirements.

Materials

Furnished in Copper-Free Aluminum (Type 6061-T6).

FIXTURE (Olympus™)

Body

Fully machined from solid billet. Unibody design provides enclosed, water-proof wireway and integral heat sink for maximum component life. High temperature, silicone 'O' Ring provides water-tight seal.

Cap

Fully machined. Accommodates [2] lens or louver media. Choose from 45° cutoff ('A' or 'D'), 1" deep bezel with 90° cutoff ('B' or 'E') or flush lens ('C') cap styles. 'A' and 'B' caps include weep-hole for water and debris drainage. 'D' and 'E' caps exclude weep-hole and are for interior use only.

Lens

Shock resistant, tempered, glass lens is factory adhered to fixture cap and provides hermetically sealed optical compartment.

BKSSL™

Integrated solid state system with 'x' technology is scalable for field upgrade. Modular design with electrical quick disconnects permit field maintenance.

LM-80 certified. Minimum 50,000 hour rated life at 70% of initial lumens (L70). BKSSL technology provides long life, significant energy reduction and exceptional thermal management.

Color Management

Corrected cold phosphor technology delivers near-perfect natural white light. Long term phosphor maintenance over product life. Exact color point conformity exceeds ANSI C78.377 standard. Provides uniform beam with no color variation over angle. Module exceeds 80 CRI (RA>80, R9>16).

Optics

Interchangeable OPTIKIT™ modules permit field changes to optical distribution.

Wiring

Teflon® coated, 18AWG, 600V, 250° C rated and certified to UL 1659 standard.

Hardware

Tamper-resistant, stainless steel hardware. Canopy mounting screws are additionally black oxide treated for additional corrosion resistance.

DRIVER HOUSING (PM3™)

Surface Mount

For use with side entry, surface conduits. Stainless steel mounting brackets provide for direct anchor to architectural surfaces in any orientation.

Round CamLock™ Canopy (Recessed Junction Box)

5" diameter, machined aluminum construction. Includes stainless steel universal mounting ring for use with 4" octagonal junction box. [2] tamper-resistant, black oxide stainless steel mounting screws. 1/8" thick HT-805A silicone foam gasket for water-tight seal. Integral CamLock™ provides additional 30° adjustment for precision alignment of UPM regardless of junction box orientation. Integral wiper seal maintains water-tight integrity between UPM and junction box. Optional stainless steel mounting brackets may be specified to provide additional anchor to architectural surface.

Housing

Copper free, aluminum extrusion with die cast end caps. Surface mounted with flow through back channel to prevent water and debris collection. Machined aluminum cover with countersunk holes for flush hardware installation. Tamper-resistant, captive, black oxide stainless steel mounting screws. Front access for ease of installation and inspection. [2] 1/2" NPT female conduit entries per end cap for through wiring.

Installation Tether

Stainless steel cable with integral loop allows cover to temporarily suspend from housing during installation to simplify wire connection and component attachment.

Patented Knockouts

[4] 3/4" NPT, machined aluminum knockouts. High temperature, silicone 'O' Ring for water-tight seal. Patented design allows knockout to be reinserted without compromising seal integrity.

Drivers

[2]700mA, Class A, constant current drivers. 120-277VAC (nominal) primary input voltage. 50/60Hz. >0.94 Power Factor, <15.0A in-rush current, 0.25A input current, ≤20%THD (nominal at 120VAC full load). Output over-voltage, over-current, and short circuit protection with auto recovery. EMC: FCC47CFR Part 15 Class B compliant.

Dimming drivers for use with standard incandescent dimmers. 10-100% range.

Finish

StarGuard®, our exclusive RoHs compliant, 15 stage chromate-free process cleans and conversion coats aluminum components prior to application of Class 'A' TGIC polyester powder coating. Finish to match fixture.

Warranty

5 year limited warranty.

Certification and Listing Olympus™

ITL tested to IESNA LM-79. Lighting Facts Registration per USDOE (www.lightingfacts.com). ETL Listed to ANSI/UL Standard 1598 and Certified to CAN/CSA Standard C22.2 No. 250. RoHs compliant. Suitable for indoor or outdoor use. Suitable for use in wet locations. IP66 Rated. Made in USA.

PM3

NEMA 4X / IP-66 Rated Enclosure. ETL Listed to ANSI/UL Standard 50/50E and Certified to CAN/CSA Standard C22.2 No. 94.1/94.2. RoHs compliant. Made in USA.



*Teflon is a registered trademark of DuPont Corporation.

B-K LIGHTING

40429 Brickyard Drive • Madera, CA 93636 • USA
559.438.5800 • FAX 559.438.5900
www.bklighting.com • info@bklighting.com

SUBMITTAL DATE
8-28-13

DRAWING NUMBER
SUB-2006-00

LED

lighting facts®

A Program of the U.S. DOE

Light Output (Lumens)	1280
Watts	34.5
Lumens per Watt (Efficacy)	37

Color Accuracy	80
Color Rendering Index (CRI)	

Light Color

Correlated Color Temperature (CCT)

2687 (Warm White)

Warranty**	Yes
------------	-----

All results, except LED Lumen Maintenance, are according to IESNA LM-79-2008: *Approved Method for the Electrical and Photometric Testing of Solid-State Lighting*. The U.S. Department of Energy (DOE) verifies product test data and results.

** See www.lightingfacts.com/products for details.

Registration Number: GCXV-WSS3KJ (7/6/2012)

Model Number: OL-LED-X21

Type: Surface-mounted fixture (other)

UT-300 Ultrasonic Occupancy Sensors

UT-300
UT-305
UT-355

1. The occupancy sensors shall be capable of detecting presence in the control area via Doppler shifts in transmitted ultrasound.
2. Sensors shall use Watt Stopper's patented ultrasonic diffusion technology that spreads coverage to a wider area.
3. Ultrasonic sensing shall be volumetric in coverage with a frequency of 40 KHz. It shall utilize Advance Signal Processing, which automatically adjusts the detection threshold dynamically to compensate for constantly changing levels of activity and airflow throughout controlled space.
4. To avoid false on activation and to provide immunity to RFI and EMI, Detection Signature Analysis shall be used to examine the frequency, duration, and amplitude of a signal so as to only respond to those signals caused by human motion.
5. Sensors of varying frequencies shall not be allowed so as to prevent sensors from interfering with each other and to assure compatibility in the event more sensors are added.
6. UT-300 and UT-305 sensors shall operate at 24 VDC/VAC and half-wave rectified and utilize a Watt Stopper power pack.
7. UT-355 shall incorporate a switching power supply for reduced power consumption; operate at 120/230/277/347 VAC, 50/60 HZ; and not require a power pack.
8. Detection shall be maintained only when a person of average size and weight moves within a maximum distance of twelve inches horizontally or vertically at the approximate speed of 12 inches per second. The sum of this distance, volume and speed represents the average condition ultrasonic sensors must meet so that the lights not go off when a person is reading or writing while seated at a desk.
9. The UT-300 and UT-305 sensors shall have a manual-on function that is facilitated by installing a momentary switch.
10. Sensors shall be mounted to the ceiling with a flat, unobtrusive appearance and provide 360° of coverage.
11. Sensors shall utilize SmartSet™ technology that automatically adjusts time delay settings to fit occupants' usage patterns for optimal energy efficiency. SmartSet feature shall be selectable with a DIP switch. Sensor shall have user-adjustable sensitivity setting.
12. Sensor shall feature a walk-through mode that turns lights off three minutes after the area is initially occupied if no motion is detected after the first 30 seconds.
13. Sensors shall cover 360° and walking motion up to 500 square feet for UT-300-1/UT-305-1/UT-355-1, 1000 square feet for UT-300-2/UT-305-2/UT-355-2, and 2000 square feet for UT-300-3/UT-305-3/UT-355-3.
14. Hallway and corridor sensors shall be a UT-300-3/UT-305-3/UT-355-3 and shall cover 45 feet in each direction for a ten-foot wide walled hallway.
15. UT-300 sensor shall have an additional single-pole, double throw isolated relay with normally open, normally closed, and common outputs. The isolated relay shall be for use with HVAC control, data logging, and other control options.
16. Sensors shall have a DIP switch-adjustable time delay of five to 30 minutes.
17. Sensors shall feature terminal style wiring for easier installation.
18. The sensor shall have a constantly active LED indicator to verify detection within the control area. Disabling LED for applications that requires less visibility shall be possible.
19. To ensure quality and reliability, sensor shall be manufactured by an ISO 9002-certified manufacturing facility and shall have a defect rate of less than 1/3 of 1%.
20. Sensor shall have standard five-year warranty and shall be UL and CUL listed.



legrand



UT-300 Series Ultrasonic Low Voltage Ceiling Sensors



PROJECT
LOCATION/TYPE

Product Overview

Description

WattStopper's UT-300 Ultrasonic Ceiling Sensors automatically turn lighting on and off based on occupancy. The sensors mount on the ceiling with a flat, unobtrusive appearance and provides 360° coverage.

Operation

UT-300 Series Sensors operate on 24 VDC, VAC or halfwave rectified. They use 40 KHz high frequency ultrasound to sense occupancy and automatically turn lighting on. When no occupancy is detected for the length of the time delay, lighting automatically turns off. For manual-on operation, the units work with a low-voltage momentary switch.

Time Delay Options

The UT-300 is factory set for a 20 minute time delay, ideal for both energy savings and user satisfaction in most applications. Installers can quickly select other fixed time delays (5, 10, 15 or 30 minutes) via DIP switches. Fixed time delays eliminate the occupant dissatisfaction associated with an automatically adjusted time delay option, and reduce callbacks. Walk-through mode may be enabled for added energy savings in spaces with frequent transient traffic.

Application

UT-300 Series Sensors offer excellent control of lighting for many spaces, including restrooms, large offices, open office areas and hallways. They can control large partitioned office spaces when configured in zone patterns. Unit performance combined with ease of installation will provide fast payback and many years of energy savings.

Features

- Advanced control logic based on RISC microcontroller provides:
 - Advanced Signal Processing eliminates false triggers and provides immunity to RFI and EMI
 - Walk-through mode turns lights off three minutes after the area is initially occupied – ideal for brief visits such as mail delivery
- LED indicates occupancy detection
- Coverage 500-2,000 square feet
- Available with isolated relay for integration with BAS or HVAC
- DIP switch simplifies sensor adjustments
- Patented ultrasonic diffusion technology spreads coverage to a wider area
- UT-300 Series Sensors work with low-voltage momentary switches for manual control
- Clip mounting system makes ceiling tile installation simple
- Uses plug terminal wiring system for quick and easy installation
- Qualifies for ARRA-funded public works projects
- Sensor coverage tested to NEMA Guide Publication WD 7-2000



Specifications

- 24 VDC/VAC
- Time delays: 5, 10, 15, 20 or 30 minutes, Walk-through/Test Modes
- Sensitivity adjustment: variable with trimpot
- Ultrasonic frequency: 40 kHz
- UT-300 contains isolated relay with N/O and N/C outputs; rated for 1 Amp at 30 VDC/VAC

- Mounting options: ceiling tile; 4" square junction box with double-gang mud ring
- Max. UT-300s per power pack: B=2, BZ=3
- Max. UT-305s per power pack: B=3, BZ=4
- Dimensions: 4.5" x 1" (114.3mm x 25.9mm) diameter x depth
- UL and cUL listed
- Five year warranty

Wiring & Mounting

Wiring Diagram

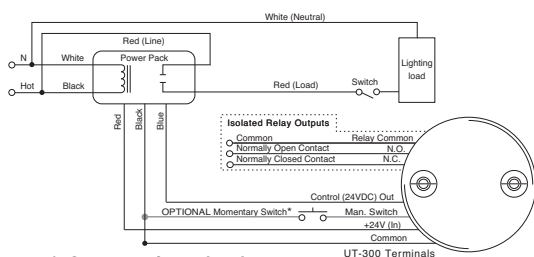

* Connect wire only when momentary switch is installed

Ceiling Mounting

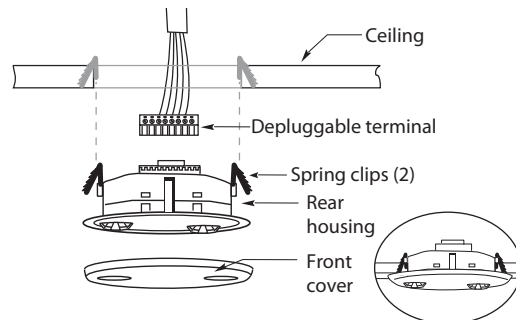

Controls & Settings

Product Controls

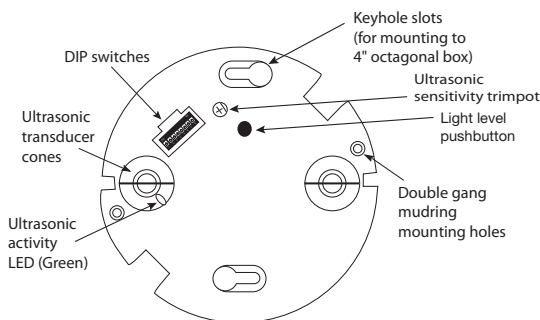

DIP Switch Settings

Feature	Switch#
Time Delay	1 2 3
Test Mode/20 min	↓ ↓ ↓
30 seconds	↓ ↓ ↓
5 minutes	↓ ↑ ↓
10 minutes	↓ ↑ ↑
15 minutes	↑ ↓ ↓
20 minutes	↑ ↓ ↑
25 minutes	↑ ↑ ↓
30 minutes	↑ ↑ ↑

Walk-Through	4
Enabled	↑
Disabled	↓ ◀
Service	5
Service	↑
Normal	↓ ◀

◀ = Factory Setting
 ↑ = ON
 ↓ = OFF

Coverage & Placement

Coverage Patterns

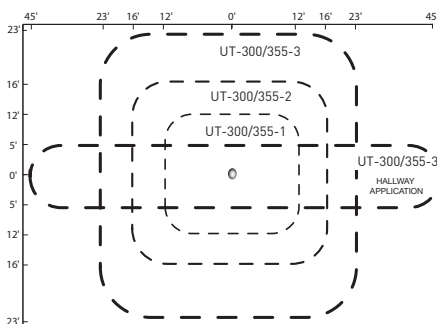

Coverages shown represent half-step walking motion when sensor is mounted 8'-10' high. Actual coverage can vary for each application depending on the shape and use of space and the obstacles present.

Placement

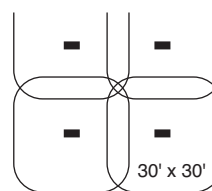

Typical layout for open office space would be to place UT-300-3 sensors so they control zones that overlap. For partitioned spaces, a typical zone is about 25' x 25' with an overlap on the coverage up to 30' x 30'.

Ordering Information

Catalog No.	Voltage	Current	Coverage	Feature
<input type="checkbox"/> UT-300-1	24 VDC	40 mA	500 ft ² (46.5 m ²)	Isolated relay
<input type="checkbox"/> UT-300-1-U				
<input type="checkbox"/> UT-300-2	24 VDC	40 mA	1000 ft ² (92.9 m ²)	Isolated relay
<input type="checkbox"/> UT-300-2-U				
<input type="checkbox"/> UT-300-3	24 VDC	45 mA	2000 ft ² (185.8 m ²)	Isolated relay
<input type="checkbox"/> UT-300-3-U				
<input type="checkbox"/> UT-305-1	24 VDC	30 mA	500 ft ² (46.5 m ²)	
<input type="checkbox"/> UT-305-2	24 VDC	30 mA	1000 ft ² (92.9 m ²)	
<input type="checkbox"/> UT-305-3	24 VDC	35 mA	2000 ft ² (185.8 m ²)	

All units are white and use WattStopper power packs. Current consumption can be slightly higher when only one sensor per power pack is used. -U = ARRA compliant. Product produced in the U.S.

April 9th, 2014

Appendix B

Affected Panelboard Original Schedules

P21B

P23

L42

L44

EP2B

April 9th, 2014

VOLTAGE:		120/208		3 PHASE		4 WIRE		TOTAL WATT'S L1	9,650	DESIGNATION	P21B				
MAIN BREAKER:		MLO		FRAME:		TRIP:		TOTAL WATT'S L2	8,666	1 OF 1 TUBS					
MAIN BUS:		225A		MOUNTING:				TOTAL WATT'S L3	13,582	LOCATION: LEVEL 1					
NOTE:								TOTAL WATT'S	31,998	Elec. Rm					
LOAD	DIRECTORY	WATT'S LOAD			CKT.	AMPS	L1 L2 L3 Y Y Y			AMPS	CKT.	WATT'S LOAD			LOAD
		L1	L2	L3			L1	L2	L3			DIRECTORY			
R	RECEPTION REC	800			1	20	•			20	2	864			DISPOSER 1/2HP F1113
R	FIRE COMMAND REC		600		3	20	•			20	4		360		RECEP. ST-11
R	LOBBY RECEP.			720	5	20	•			20	6			540	GFCI
R	LOBBY REC	1,000			7	20	•			20	8	720			RECEP. F113
R	LARGE CONF.		800		9	20	•			20	10		800		SP1 PANEL RM F103
R	LARGE CONF., PART.			1,000	11	20	•			20	12			1,176	FCU-3 1/2HP
R	LARGE CONF.	800			13	20	•			20	14	864			FCU-4 1/3HP
R	TV REC		600		15	20	•			50	16		2,400		FCU-4 (2) 3/4HP
R	OFFICE			1,000	17	20	•			50	18			2,400	FPB-2 (2) 3/4HP
R	CORRIDOR TV	800			19	20	•			20	20	200			SP1 RECEPTACLE
R	LOAD DCCK		400		21	20	•			20	22		800		VP AND MS
R	ELEV. EM			400	23	20	•			20	24			1,524	LEVEL 1 VALVRP-1-3.5
E	DOOR POWER SUPPLY	800			25	20	•			20	26	1,684			LEVEL 1 LVVRP-1-6
E	FCU-10 (2) 1/110HP				27	30	•			20	28		1,226		LEVEL 1 LVVRP-1-7
E	FDCCG-70 (2) 3/4HP			2,400	29	50	•			20	30			1,250	LOBBY LTG
R	QUAD F11	360			31	20	•			20	32	758			LEVEL 1 LVVRP-1-11
R	RECEP. F104		180		33	20	•			20	34		500		RECEP. F114 & FCU-34
L	LEVEL 1 VIA LVVRP-1-2			912	35	20	•			20	36			360	RECEP. F114
S	SPARE				37	20	•			20	38				SPARE
S	SPARE				39	20	•			20	40				
S	SPARE				41	20	•			20	42				
SUBTOTAL		4,560	2,580	6,432								5,090	6,086	7,250	SUBTOTAL

RECEPTACLE LOADS: 12,140 WATTS
 EQUIPMENT LOADS: 12,534 WATTS
 LIGHTING LOADS: 7,354 WATTS
 DEMAND LOADS: 30,928 WATTS

TOTAL AMPS x 125%= 107.375 AMPS

VOLTAGE:		120/208		3 PHASE		4 WIRE		TOTAL WATT'S L1	15,975	DESIGNATION	P23				
MAIN BREAKER:		MLO		FRAME:		TRIP:		TOTAL WATT'S L2	18,807	2 OF 2 TUBS					
MAIN BUS:		225A		MOUNTING:				TOTAL WATT'S L3	12,008	LOCATION: LEVEL 3					
NOTE:								TOTAL WATT'S	46,790	Elec. Rm					
LOAD	DIRECTORY	WATT'S LOAD			CKT.	AMPS	L1 L2 L3 Y Y Y			AMPS	CKT.	WATT'S LOAD			LOAD
		L1	L2	L3			L1	L2	L3			DIRECTORY			
R	OFFICE TB-01	800			43	20	•			20	44	800			OFFICE AD-03
R	OFFICE SG-01		1,000		45	20	•			20	46		800		OFFICE AD-04
R	OFFICE AD-02			800	47	20	•			20	48			800	OFFICE AD-05
R	OFFICE AD-01	1,000			49	20	•			20	50	1,200			MW
R	TELDA*A QUAD F303		400		51	20	•			20	52		1,200		COFFEE MACH.
R	TELDA*A QUAD F303			400	53	20	•			20	54			800	DW
E	SP3A PANEL F303	800			55	20	•			20	56	800			DISP
E	SP3B PANEL F303		800		57	20	•			20	58		600		ICE MAKER
R	SP3A RECEPTACLE			200	59	20	•			20	60			600	REF
R	TRM F303	400			61	20	•			20	62	400			COUNTER REC
R			400		63	20	•			20	64		367		LIGHTING
R				400	65	20	•			20	66				LIGHTING
R		400			67	20	•			20	68				SPARE
R				1,000	69	30	•			20	70				
S	SPARE				71	20	•			20	72				
S					73	20	•			20	74				
S					75	20	•			20	76				
S					77	20	•			20	78				
S					79	20	•			20	80				
S					81	20	•			20	82				
S					83	20	•			20	84				
SUBTOTAL		8,275	9,640	5,808								7,700	9,167	6,200	SUBTOTAL

RECEPTACLE LOADS: 21,140 WATTS
 EQUIPMENT LOADS: 24,400 WATTS
 LIGHTING LOADS: 883 WATTS
 DEMAND LOADS: 40,853 WATTS

TOTAL AMPS x 125%= 141.832 AMPS

April 9th, 2014

VOLTAGE:		277-480	3 PHASE		4 WIRE		TOTAL WATT'S L1		6,129	DESIGNATION		L42				
MAIN BREAKER:		MLO	FRAME:		TRIP:		TOTAL WATT'S L2		6,668	LOCATION:		1 OF 1 TUBS				
MAIN BUS:		100A	MOUNTING:				TOTAL WATT'S L3		8,704	LEVEL 2						
NOTE:							TOTAL WATT'S		20,492	Elec. Rm						
LOAD	WATT'S LOAD						L1 Y	L2 Y	L3 Y	AMPS	CKT.	WATT'S LOAD			LOAD	
	DIRECTORY	L1	L2	L3	AMPS	CKT.						L1	L2	L3		DIRECTORY
L	BASEMENT	1,100							20	2				STAIR 2	L	
L	STAIR 1								20	4		800		LVL 2, CORE	L	
L	LVL 1 CORE				1,200				20	6			2,304	LVL 3, CORE	L	
L	LVL 1 ELEC & LD DOCK	1,480							20	8	1,091			BASEMENT	L	
L	LEVEL 1		900						20	10		700		↓	L	
L	LEVEL 2				512				20	12			1,380	PV HIGH BAY	L	
S	SPARE								20	14				SPARE	L	
S	SPARE								20	16		763		LEVEL 1 LTG	L	
S	SPARE								20	18			1,408	LEVEL 2	L	
L	LEVEL 2 LVFRP-1-15	203							20	20	1,104			LEVEL 2 LVFRP-1-13,14,15	L	
S	SPARE								20	22		2,300		LEVEL 3	L	
L	LEVEL 3				900				20	24			800	LEVEL 3 LVFRP-1-20,21	L	
L	LIGHTING:	942							20	26						L
L	LIGHTING: CCNTRCLS		200						20	28						L
L	LIGHTING: CCNTRCLS			200					20	30						L
L	LIGHTING: CCNTRCLS	200							20	32						L
									20	34						L
									20	36						L
									20	38						L
									20	40						L
									20	42						L
	SUBTOTAL	3,925	1,100	2,812							2,195	4,568	5,892		SUBTOTAL	

RECEPTACLE LOADS: 0 WATTS
EQUIPMENT LOADS: 0 WATTS
LIGHTING LOADS: 20,492 WATTS
DEMAND LOADS: 20,492 WATTS

TOTAL AMPS x 125%⁶⁰: 30.8288 AMPS

VOLTAGE:		277-480	3 PHASE		4 WIRE		TOTAL WATT'S L1		2,850	DESIGNATION		L44				
MAIN BREAKER:		MLO	FRAME:		TRIP:		TOTAL WATT'S L2		1,149	LOCATION:		1 OF 1 TUBS				
MAIN BUS:		100A	MOUNTING:				TOTAL WATT'S L3		300	LEVEL 4						
NOTE:							TOTAL WATT'S		4,299	Elec. Rm						
LOAD	WATT'S LOAD						L1 Y	L2 Y	L3 Y	AMPS	CKT.	WATT'S LOAD			LOAD	
	DIRECTORY	L1	L2	L3	AMPS	CKT.						L1	L2	L3		DIRECTORY
L	LVL 6 CORE	832							20	2				STAIR 2	L	
L	STAIR 1								20	4		300		LVL 6 CORE	L	
L	LVL 5 CORE								20	6				PENTHOUSE	L	
L	LEVEL 6 LVFRP-2-5	1,968							20	8				LVL 6 EXTR. LTG	L	
L	LEVEL 6 LVFRP-2-1		205						20	10		644		LEVEL 6	L	
									20	12			300	LEVEL 6 VIA LVFRP-2-9	L	
									20	14						L
									20	16						L
									20	18						L
									20	20						L
									20	22						L
									20	24						L
									20	26						L
									20	28						L
									20	30						L
									20	32						L
									20	34						L
									20	36						L
									20	38						L
									20	40						L
									20	42						L
	SUBTOTAL	2,850	205	0							0	944	300		SUBTOTAL	

RECEPTACLE LOADS: 0 WATTS
EQUIPMENT LOADS: 0 WATTS
LIGHTING LOADS: 4,299 WATTS
DEMAND LOADS: 4,299 WATTS

TOTAL AMPS x 125%⁶⁰: 6.46754 AMPS

VOLTAGE:		120/208		3 PHASE:		4 WIRE		TOTAL WATT'S L1		3,664		DESIGNATION		EP2B	
MAIN BREAKER:		100A		FRAME:		TRIP:		TOTAL WATT'S L2		3,826		LOCATION:		1 OF 1 TUBS	
MAIN BUS:				MOUNTING:				TOTAL WATT'S L3		1,702				BASEMENT	
NOTE:								TOTAL WATT'S		9,192				Emrg. Elec. Rm	
LOAD	WATT'S LOAD			CKT.	AMPS	L1	L2	L3	AMPS	CKT.	WATT'S LOAD			LOAD	
	DIRECTORY	L1	L2			L3	L1	L2			L3	DIRECTORY			
E	FDP-1, LVL1 (1/4 HP)	1,400			2	20			20	2	500			ELEV CAB LTG	E
E	FDP-2, LVL1 (1/4 HP)		1,400		3	20			20	4		500		ELEV CAB PWR	E
E	LVL 1 FACP				5	20			20	6			500	ELEV REM. MONTR	E
E	LVL 1 FACP				7	20			20	8	500			GEN. PWR	E
E	LVL 4 FACP				9	20			20	10		500		GEN. LTG	E
R	LVL 4 FACP				11	20			20	12			200	EMRG ELEC RM REC	R
R	LVL 6 EDA				13	20			20	14	200			FIRE PUMP REC	R
R	LVL 6 EDA				15	20			20	16		500		ELEV PIT & CNTRL RM	R
R	BSMNT: SMOKE DAMP				17	20			20	18			550	TOP ELEV SHAFT	R
E	LVL 1 SMOKE DAMP				19	20			20	20	200			BSMNT HEAT TRACE	E
L	LVL 2 SMOKE DAMP				21	20			20	22		75		LIGHTING VESTIBULE	L
L	LVL 3 SMOKE DAMP				23	20			20	24			75	LVL 1 LIGHTING	L
E	LVL 4 SMOKE DAMP				25	20			20	26	864			FIRE SHUTTER	E
E	LVL 5 SMOKE DAMP				27	20			20	28		200		FIRE SHUTTER CTRL	E
L	LVL 6 SMOKE DAMP				29	20			20	30			377	LVL 2 LIGHTING	L
S	SPARE				31	20			20	32				SPARE	S
L	LVL 6 LIGHTING		390		33	20			20	34		203		LVL 3 LIGHTING	L
S	SPARE				35	20			20	36				SPARE	S
S					37	20			20	38					S
S					39	20			20	40					S
S					41	20			20	42					S
SUBTOTAL		1,400	1,790	0							2,264	2,036	1,702	SUBTOTAL	
RECEPTACLE LOADS:		1,530		WATTS											
EQUIPMENT LOADS:		6,554		WATTS											
LIGHTING LOADS:		1,128		WATTS											
DEMAND LOADS:		9,192		WATTS											
											TOTAL AMPS x 125%		31.9124 AMPS		

Appendix C

Floor Plan of 3rd floor, 4th floor and 5th Floor

Owner
SCC LLC
617.423.6205
617.423.6270

Construction Manager
GILBANE BUILDING CO.
617.478.3300
617.478.3301

Structural Engineer
MCNAMARA/SALVIA, INC.
617.737.0040
617.737.0042

MEP/FP/Tel Data Engineer
BR+A CONSULTING ENGINEERS
617.254.0016
617.924.9339

Civil Engineer
VHB, INC.
617.728.7777
617.728.7782

Geotechnical Engineer
HALEY & ALDRICH, INC.
617.886.7400
617.886.7692

Historical Consultant
MACROSTIE HISTORIC ADVISORS, LLC
617.499.4009
617.499.4019

Code Consultant
C3, INC.
617.330.9390
617.330.9383

Landscape Architect
HALVORSON DESIGN PARTNERSHIP, INC.
617.536.0380
617.536.0626

ARCHITECTURAL LEGEND

-  EXISTING TO REMAIN
-  NEW WORK

GENERAL NOTES:

1. ALL INTERIOR DIMENSIONS ARE TO FINISH-FACE UNLESS OTHERWISE NOTED
2. CONTRACTOR SHALL FIELD VERIFY ALL DIMENSIONS. ANY DISCREPANCIES SHALL BE BROUGHT TO THE ATTENTION OF THE ARCHITECT FOR RESOLUTION
3. SEE A6.2 FOR PARTITION TYPES
4. ALL INTERIOR FINISHES AND FIXTURES TO BE PROVIDED BY TENANT.
5. RATED ENCLOSURE AT COLUMNS TO BE GWS, SPRAY, OR TROWELED-ON FIREPROOFING, UNLESS OTHERWISE NOTED.
6. PLUMBING FIXTURE LAYOUT IS FOR COORDINATION ONLY. FIXTURE TO BE PROVIDED BY TENANT.

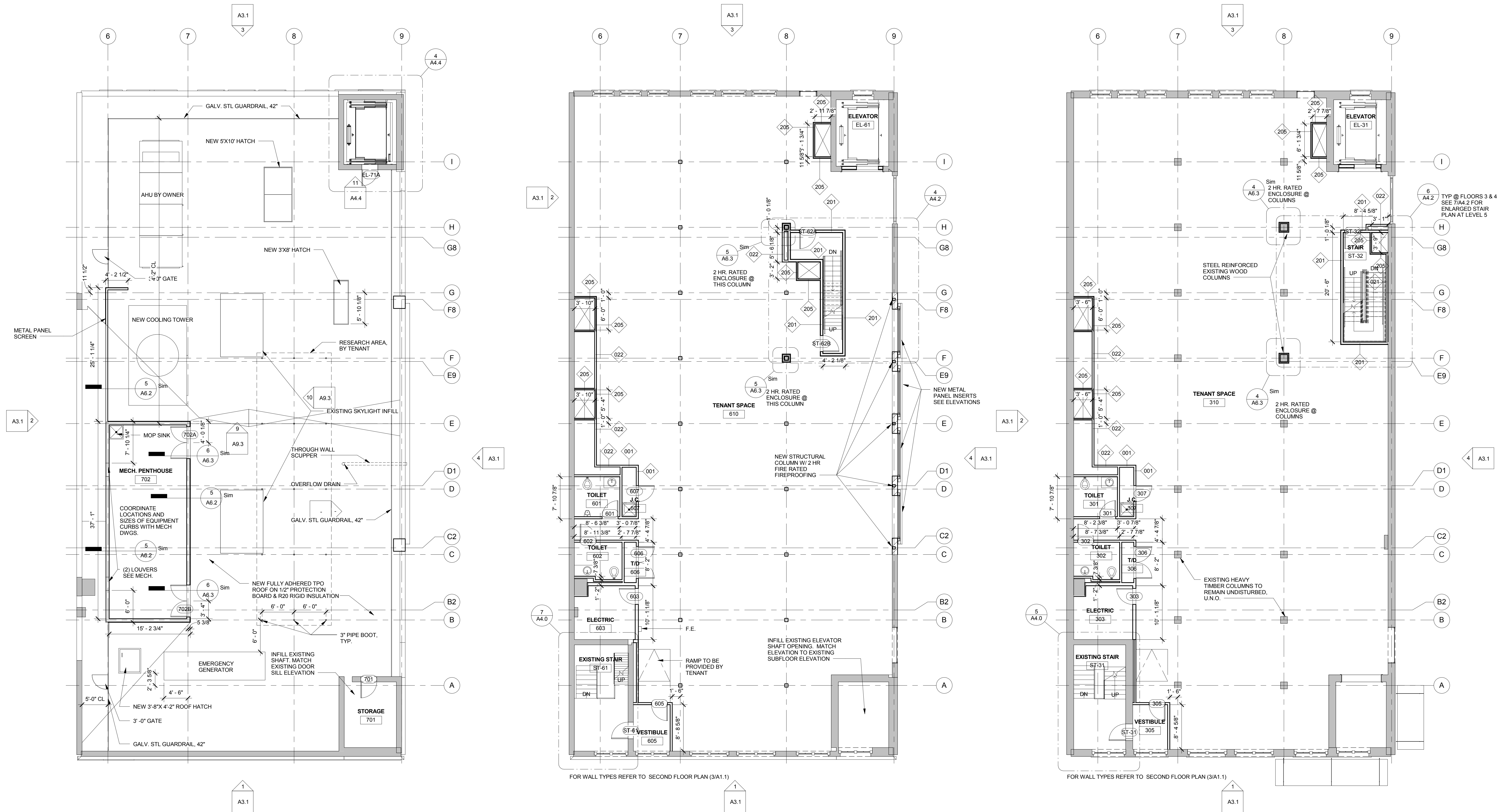

3 SC Penthouse
1/8" = 1'-0"

2 SC Level 6
1/8" = 1'-0"

1 SC - LEVEL 3 THRU 5
1/8" = 1'-0"

CONSTRUCTION SET

CONSTRUCTION SET	10.14.2011
GMP SET	3.23.2011
PERMIT SET	2.2.2011
Issue Description	Date

Scale:
1/8" = 1'-0"
Drawn By: Author
Checked By: Checker
Reviewed By:

Project No. 2010094.00

5 Channel Center - Base Building

5 Channel Center
Boston, MA 02210

FLOOR PLANS

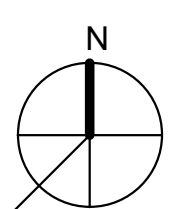

A1.2